

# LATTNER

## INSTRUCTION MANUAL WLF MODELS 9.5 HP TO 50 HP



### **Lattner Boiler Company**

1411 9<sup>th</sup> St. SW  
Cedar Rapids, IA 52404

T: (800) 345-1527

F: (319) 366-0770

E: [info@lattner.com](mailto:info@lattner.com)

[www.lattnerboiler.com](http://www.lattnerboiler.com)

# WARRANTY VALIDATION & BOILER START UP REPORT

The following information must be recorded during each boiler start up. This information must be returned to Lattner Boiler Manufacturing Company for warranty validation. If this information is not returned, warranty consideration may not be extended.

Lattner Boiler Model: \_\_\_\_\_  
National Board Number ("NB"): \_\_\_\_\_  
Lattner Dealer Name: \_\_\_\_\_  
Start Up Company: \_\_\_\_\_  
Start Up Date: \_\_\_\_\_  
Start Up Technician: \_\_\_\_\_

Owner Name: \_\_\_\_\_  
Company Name: \_\_\_\_\_  
Street Address (start up location): \_\_\_\_\_  
State: \_\_\_\_\_  
Zip Code: \_\_\_\_\_  
Telephone Number: \_\_\_\_\_

Natural Gas or  LP (Propane) Gas  
Gas Pressure at Train Inlet: \_\_\_\_\_" w.c. (boiler OFF)  
Gas Pressure at Train Inlet: \_\_\_\_\_" w.c. (boiler ON)  
Manifold Pressure: \_\_\_\_\_" w.c. (boiler OFF)  
Manifold Pressure: \_\_\_\_\_" w.c. (boiler ON)  
Gas Pressure at Pilot Tee: \_\_\_\_\_" w.c. (boiler OFF)  
Gas Pressure at Pilot Tee: \_\_\_\_\_" w.c. (boiler ON)  
Input: \_\_\_\_\_btu/hr (cu. ft clocked at meter)

Voltage: \_\_\_\_\_v / \_\_\_\_\_ph / \_\_\_\_\_hz  
Pilot Signal Reading: \_\_\_\_\_VDC  
O<sub>2</sub>: \_\_\_\_\_%  
CO<sub>2</sub>: \_\_\_\_\_%  
CO: \_\_\_\_\_parts per million (ppm)  
NO<sub>x</sub>: \_\_\_\_\_parts per million (ppm)  
Stack Temperature: \_\_\_\_\_degrees Fahrenheit  
Combustion Efficiency: \_\_\_\_\_%

Limit Control Setting (cut out): \_\_\_\_\_psi or °F  
Operating Control Setting: \_\_\_\_\_psi or °F  
Operating Control Differential Setting: \_\_\_\_\_psi or °F

Modulating Control Setting: \_\_\_\_\_psi or °F  
Modulating Control Differential Setting: \_\_\_\_\_psi or °F

Checked for proper operation of:

Low Water Cut Off  yes  no  
High Water Cut Off  yes  no  
Flame Safeguard Control Ignition  yes  no  
Flame Safeguard Main Flame  yes  no  
Air Flow Switch  yes  no

Barometric Damper  yes  no  
Boiler Combustion Air  yes  no  
Boiler Flue/Stack Compliance  yes  no  
Gas Line Leakage  yes  no  
Gas Equipment Ventilation  yes  no

Notes:

**IMPORTANT:** For warranty validation, return this document to (mail, fax, or email):

Lattner Boiler Manufacturing Company  
P.O. Box 1527  
Cedar Rapids, IA 52406  
T: (319) 366-0778  
F: (319) 366-0770  
E: [info@lattner.com](mailto:info@lattner.com)

## Index

|   |                |
|---|----------------|
| <b>General Description</b>                  | <b>Page 4</b>  |
| A. Boiler Design                            | 4              |
| B. Boiler Connections                       | 4              |
| C. Boiler Trim                              | 5              |
| D. Fuel Burning System                      | 5              |
| E. Fuel Train                               | 6              |
| F. Control Panel                            | 6              |
| G. Combustion Safeguard                     | 6              |
| H. Guarantees                               | 6              |
| I. Factory Tests                            | 7              |
| J. Nameplates & Stamping                    | 7              |
| <br>  |                |
| <b>Section I: Installation</b>              | <b>Page 8</b>  |
| A. Unloading                                | 8              |
| B. Rigging                                  | 8              |
| C. Placement of Boiler                      | 8              |
| D. Combustion Air                           | 8              |
| E. Stack                                    | 9              |
| F. Boiler Shipped with Controls<br>Removed  | 9              |
| G. Steam Outlet                             | 9              |
| H. Blowdown Piping                          | 9              |
| I. Safety Valve                             | 10             |
| J. Gas Train Piping                         | 10             |
| K. Boiler Feed Systems                      | 11             |
| L. Electrical Connections                   | 12             |
| M. Before Firing The Boiler                 | 12             |
| N. Pressuretrols: Controller & Limit        | 12             |
| O. Start Up of Standard Burners             | 13             |
| <br>  |                |
| <b>Section II: Boiler Care</b>              | <b>Page 15</b> |
| A. General                                  | 15             |
| B. New Boiler Clean Out                     | 15             |
| C. Water Conditions                         | 15             |
| D. Water Treatments & Chemicals             | 15             |
| E. Water Softener                           | 15             |
| F. Foaming, Bouncing, & Chemicals           | 15             |
| G. Water Treatment Summary                  | 16             |
| H. Blowdown                                 | 16             |
| I. Feedwater System                         | 16             |
| J. Burner Adjustment                        | 16             |
| K. Sight Glass                              | 17             |
| L. External Inspections                     | 17             |
| M. Internal Inspections                     | 18             |
| <br>  |                |
| <b>Section III: Maintenance</b>             | <b>Page 19</b> |
| A. Daily Blowdown                           | 19             |
| B. Weekly Maintenance                       | 19             |
| C. General Maintenance                      | 19             |
| D. Table 1: Recommended Testing<br>Schedule | 20             |
| E. Hand Hole Plate Removal & Re-            | 21             |

|   |    |
|---|----|
| Installation                                  |    |
| F. Sight Glass Removal & Re-Installation      | 22 |
| G. McDonnell Miller Servicing                 | 23 |
| H. Cleaning Interconnecting Pipe              | 23 |
| I. Warrick Relay Replacement                  | 24 |
| J. Auxiliary Low Water Cut-Off Probe Cleaning | 24 |

**Section IV: Troubleshooting** .....Page 25

|                        |    |
|------------------------|----|
| A. Normal Operation    | 25 |
| B. Basic Service Tools | 25 |
| C. Before You Begin    | 25 |

**Lattner Boiler Limited Warranty** .....Page 28

**Standard Terms & Conditions** .....Page 29

**Product Support Literature** .....Page 30

## General Description

**WARNING:** All installation procedures must be followed completely by a competent installer familiar with boilers and boiler accessories.

**CAUTION:** Read and follow all instructions before installing any boiler equipment. All cover plates, enclosures and guards must be maintained and in place at all times, except during maintenance and servicing.

### **A. Boiler Design**

The Model WLF is a four pass carbon steel vertical boiler of the waterleg tubeless design that includes an integral furnace and extended conductive heat transfer surfaces. The furnace is completely submerged within the normal operating water level. In accordance with the latest edition of the ASME Code, the boiler is constructed for either low pressure steam or high pressure steam to 150 psi.

#### **1. Gas Flow**

Heat transfer design of the Model WLF boiler provides four pass flow to ensure maximum heated gas travel and heat transfer. Refractory lined steel exhaust ports are incorporated for heated gas flow direction from the furnace to the finned convection surfaces. Symmetrical finned design and layout provides equalized flow of heat into each convection section from the furnace and successive gas passes, ensuring high efficiency.

#### **2. Water Circulation**

Feedwater make-up and/or return enter the bottom of the vessel below the steaming surface. By directing the make-up into a non-steaming portion of the boiler, we eliminate the possibility of collapsing steam bubbles and thereby work in harmony with the natural water circulating pattern within the boiler.

#### **3. Tubeless**

Boiler tubes are eliminated with the use of extended finned heat transfer surfaces. These fins are seal welded to the pressure vessel to enhance heat absorption into the boiler water. Fouling, plugging, and replacement of tubes are eliminated with the use of extended finned surfaces.

#### **4. Furnace**

The combustion chamber or furnace is centrally located within the pressure vessel. It consists of a single cylindrical tube attached to the top of the pressure vessel with ASME Code required stay bolts. It is symmetrical in layout and completely water backed, assuring a balanced flow circulating pattern under all load conditions.

#### **5. Inner Casing**

A non-metallic gas barrier encases the heat transfer fins, to ensure proper gas travel from the combustion chamber into each heat transfer zone. This barrier is covered with a steel wrapper that is in turn covered with a minimum 1-1/4" ceramic blanket, minimizing heat loss

and ensuring high fuel to steam efficiency. Blanket density exceeds 8 pounds per cubic foot. The steel inner wrapper ensures that the combustion byproducts will not diffuse through the blanket insulation and into the boiler room.

#### **6. Outer Casing**

The removable outer casing is fabricated of four 16 gauge octagonal steel panels. Each panel is painted by a powder coating process on the inner and outer surfaces, ensuring corrosion resistance and longevity. Air space between the insulation and outer casing as well as the extra thick inner insulation provides a jacket temperature near ambient conditions.

#### **7. Waterside Inspection**

A minimum of two hand hole inspection plates are provided in the pressure vessel near the bottom for visual inspection and cleaning of the waterside internals. One hand hole inspection plate is located on the top of the boiler for additional waterside inspection.

#### **8. Flame Observation Port**

For visual inspection of the pilot and main flame ignition, a sight port is provided in the burner housing.

#### **9. Boiler Lifting Lugs**

One lug for 10 to 20 horsepower and two lugs on larger units are provided to facilitate lifting and rigging the boiler into place. The lug(s) is located on the top centerline of the pressure vessel.

#### **10. Boiler Base Frame**

A structural steel welded base is provided upon which the boiler is placed. The minimum height of the structural base is 4 inches and the boiler is welded to the base at four points.

### **B. Boiler Connections**

The following connections are factory installed in accordance with the ASME:

#### **1. Steam Connection**

The system supply connection is located on the top of the boiler and is threaded as standard. In some instances or for specific project requirements, the nozzle connection may be flanged.

## 2. Boiler Blowdown Valve/Drain

A boiler blowdown valve is provided on the front right side of the pressure vessel to completely drain the boiler as required, and for periodic bottom blowdown.

## 3. Feedwater Make-Up

A valve is provided on the front centerline of the pressure vessel near the bottom for connection to the system make-up and/or condensate return.

## 4. Exhaust Gas Vent

The connection for the stack or breaching is located at the rear near the top of the boiler. This is a sleeve connection, with the opening in accordance with the nominal dimension and rating sheets.

## C. Boiler Trim

The following are factory installed standard trim and control items. Trim items are provided in accordance with the ASME Code and the controls and are UL listed.

### 1. Relief Valve

In compliance with the ASME Code, a steam boiler pressure relief valve(s) is provided. Size and quantity are determined by the valve setting, valve capacity, and the ASME Code. These may be shipped loose to prevent possible damage during shipment.

### 2. Water Column

Factory mounted and piped complete with gauge glass, gauge glass drain valve, gauge glass isolation valves, column drain valve, and a minimum of 1" equalized piping and crosses for inspection and clean-out.

### 3. Low Water Cut-Off

To prevent burner operation whenever a low water condition occurs, an electronic probe-sensing device, or float operated control is furnished in the water column. This device is wired in series to the burner combustion safeguard control to prevent burner operation whenever a low water condition occurs.

### 4. Pump Control

When a probe sensing main level control is furnished, two stainless steel probes are furnished in the water column to provide pump ON/OFF operation for water make-up. These probes are wired to an electronic interlock relay for pump or water valve control. However, if the column is a float-actuated device, a snap acting single pole single throw switch activates a pump contactor for ON/OFF pump or solenoid valve operation.

## 5. Auxiliary Low Water Cut-Off

An additional control, separate from the primary low water control is provided to prevent burner operation if a low-low water condition exists. This device is an internal probe control located on the top of the pressure vessel, and requires manual reset whenever a low-low water condition occurs.

## 6. Steam Pressure Gauge

A 3-1/2" dial pressure gauge is furnished as standard. The range of the gauge will be in accordance with the safety valve setting, based on 1.5 times the valve setting for high-pressure units, and two times the design pressure of low-pressure units.

## 7. Steam Pressure Controls

- 9-1/2 to 25 Horsepower

Two controls are furnished; one for ON/OFF operation while the other is to prevent burner operation if excess steam pressure is sensed and requires a manual reset.

- 30 to 50 Horsepower

Three (3) controls are supplied as standard. One control provides for ON/OFF operation in response to system demand and one is provided as a safety lockout with a manual reset requirement. The third control is for burner positioning at either low fire or high fire relative to steam demand.

## 8. Valves

Standard valve piping package, 9-1/2 to 30 horsepower, consists of: one (1) main steam stop valve, one (1) feedwater stop valve, one (1) feedwater spring loaded check valve, one (1) quick open bottom blowdown valve, and one (1) slow open blowdown valve. Valves for larger sizes are not provided unless requested.

## D. Fuel Burning System

The factory-assembled boiler is furnished with a UL approved fuel burning forced draft packaged system. The packaged system is mounted and wired integral with the front centerline of the boiler.

### 1. Burner Type

The forced draft burner is designed for Natural or LP gas only.

### 2. Burner Operation

The burner is designed to operate in an ON/OFF mode for sizes 9-1/2 to 25 horsepower and LOW/HIGH/OFF for boilers 30 to 50 horsepower. Modulating burners are optional.

### 3. Ignition/Pilot

Gas-fired units are equipped with a spark ignited gas pilot assembly. The gas pilot assembly includes a pilot gas cock, gas pressure regulator, ignition transformer, and pilot solenoid valve.

### 4. Forced Draft Fan

An integral fan assembly direct connected to a NEMA fan motor supplies the required combustion air. As standard, the fan motor is an open drip proof, high efficiency type, operating at 3,450 RPM.

### 5. Air Proving Switch

An air pressure-sensing switch is mounted on the burner to prevent fan or burner operation if sufficient air is not available for proper combustion or pilot ignition.

### 6. Fuel/Air Control

The control of combustion air is managed with an integral inlet air damper operating as follows:

- 9-1/2 to 25 Horsepower

Mechanically fixed for the correct combustion air to fuel ratio for ON/OFF firing.

- 30 to 50 Horsepower

Mechanically linked with the fuel valve and air damper to provide fuel/air ratio at low fire and high fire.

### E. Fuel Train

The burner is equipped with factory mounted fuel safety control and safety shutoff valves for either natural gas or LP gas. Each fuel piping assembly is equipped, as a minimum with the following:

#### 1. Gas Assembly

Boiler base rail mounted, piped and wired gas piping assembly, consisting of main gas pressure regulator, safety shutoff valves, manual shutoff cocks, fuel input control valve, in accordance with the latest UL and CSD-1 requirements.

### F. Control Panel

A NEMA 1A enclosed (powder coated finish) control panel is mounted integral to the burner or on an independent bracket mounted on the boiler. This panel contains as a minimum the following components:

#### 1. Boiler ON/OFF Switch

Provided to interrupt control power to the 120 volt control circuit. Does not disconnect the main power source.

### 2. Pump ON/OFF Switch

Provided to isolate the pump control circuit.

### 3. Terminals

Provided for the connection of the 120/1/60 volt supply and for external connections for field wiring.

### 4. Relays

Water level control relays as described above.

### 5. Wiring/Controls

All devices and wiring are in accordance with the latest UL/NFPA 70 requirements. Each device is UL listed or recognized and bears the UL label or stamp.

### 6. Wiring/Controls

As standard, flexible conduit is used and as deemed necessary or in accordance with specifications, thin wall or rigid and seal tight may be used.

### G. Combustion Safeguard

#### 1. Solid State Control

This pre-programmed solid state control is mounted adjacent to the burner, and provides for the safe start sequencing of the burner from start-up, run, normal shutdown, and safety shutdown.

#### 2. UV Scanner

A flame-sensing device of the UV scanning principle is furnished on all boilers. Status indicating lights are furnished on the front face of this control for visual indication of the burner/boiler operation.

### H. Guarantees

#### 1. Efficiency

The boiler package is guaranteed to operate at a minimum of 80% or greater, fuel input to steam pounds per hour output efficiency.

#### 2. Warranty

The complete package is warranted for a period of one (1) year from the date of initial start-up or 18 months from the date of shipment or notice to ship, whichever occurs first.

#### 3. Damage

This guarantee does not include items that are damaged due to circumstances of carelessness, neglect, or operating the unit beyond its capacity and rating.

## **I. Factory Tests**

### **1. Pressure Vessel**

The boiler is subjected to an ASME certified hydrostatic pressure test to ensure the pressure vessel meets the standards of the ASME. In accordance with the ASME Code (Section IV Heating Boilers or Section I Power Boilers), this test is supervised by an independent inspection agency. Upon acceptance of the test by the authorized independent inspector, the unit is stamped with the "H" symbol for 15 psi design units and with the "S" symbol for 150 psi and greater designs. One copy of the ASME data sheets is provided to the purchaser. One copy is sent to the National Board of Pressure Vessel Inspectors. The original copy is archive at Lattner.

### **2. Boiler Piping Hydro**

Each Section I High Pressure Boiler ("S" stamped), is subjected to an additional hydrostatic pressure test. This test includes the integral steam and water trim piping and the trim valves. An ASME P-6 piping hydro certificate can be provided for an additional cost.

## **3. Burner/Controls**

To ensure proper operation of the combustion safeguard control, ignition, and main fuel light off the burner manufacturer subjects the packaged burner to a preliminary factory fire test. All burner and boiler controls are checked for circuit continuity and operation after mounting and wiring the burner onto the boiler.

## **J. Nameplates & Stamping**

### **1. National Board of Pressure Vessel Inspectors**

The National Board of Pressure Vessel Inspectors registration number is stamped on the pressure vessel along with the boiler serial number, year built, maximum boiler output and minimum safety valve capacity. This information is stamped on the top head of the pressure vessel. A facsimile nameplate of this data stamping is mounted near or on the front door of the boiler control panel.

## Section I: Installation

**WARNING:** All installation procedures must be followed completely by a competent installer familiar with boilers and boiler accessories.

**CAUTION:** Read and follow all instructions before installing any boiler equipment. All cover plates, enclosures and guards must be maintained and in place at all times, except during maintenance and servicing.

### A. Unloading

The boiler was loaded by Lattner (including any accessories) and accepted by the transport company as undamaged. Therefore, before unloading the equipment, determine whether any shipping damage is apparent. Once the equipment is lifted from the trailer, any damage sustained during transit and not filed with the transport company will be the responsibility of the rigger or purchaser.

#### 1. Lifting

The boiler will arrive secured to a wooden skid/pallet and will include a lifting lug (top of the boiler). When moving or lifting the unit, DO NOT attach slings around the boiler or to the burner in an attempt to pull the boiler.

#### 2. Forklift

If lifting with a forklift, extended forks should be used and placed beneath the skid. Care must be taken to ensure that the boiler sits correctly on the forks such that the unit does not topple. Always note the weight of the boiler relative to the lifting capacity of the forklift.

#### 3. Crane or Boom

When lifting with a crane or boom, attach the hook to the lifting lug on top of the boiler. DO NOT attach slings or chains to any part of the boiler, boiler piping, or burner.

### B. Rigging

Always use a competent rigger that has experience moving and setting boilers. If the unit will be moved into the permanent location with a forklift, crane, or boom follow the directions in section A. However, if moving the unit through a tight space or into an area that will not permit a forklift, etc., place the boiler on rollers or on 2" pipes and roll the boiler into place. If the unit is dragged, attach chains to the base frame only.

**CAUTION:** DO NOT lay the boiler on its side as the panels will not support the weight of the boiler without sustaining damage. If the entry is too narrow for the boiler and controls to pass through, removal of the trim and controls can be executed. One should properly denote all wiring and piping connections and match mark accordingly for attachment after the boiler is placed. It may be helpful to use a digital camera to record the location of trim items for reference.

### C. Placement of Boiler

#### 1. Floor

Boiler must be placed on a level, noncombustible surface. NEVER install boiler on a wood floor or any other combustible surface (i.e., carpet, linoleum).

#### 2. Combustible Surface

Underwriter's Laboratories specifies the following minimum clearances to combustible surfaces:

Top –48"  
Sides – 36"  
Flue Pipe –36"

#### 3. Non-Combustible Surface

When placing boiler near non-combustible surfaces (i.e., cement or cinder block walls), maintain 18" around the boiler for servicing. NOTE: Any state or local fire and building codes requiring additional clearances take precedence over the above requirements.

### D. Combustion Air

#### 1. Ventilation

The boiler room must be adequately ventilated to supply combustion air to the boiler. The vent must be opened to the outside to allow air to flow into the room. Proper sizing of the vent is important to ensure that sufficient free air is available for complete combustion and proper venting of the flue gases.

#### 2. Vent Size

Use the following chart to determine vent size for Lattner boilers. Chart based on a minimum of 1 sq. in. per 4,000 BTU input. Ideal is 1 sq. in. per 2,000 BTU input per NFPA 54. For Canada, refer to CSA B149. 1-10.

|             |           |            |
|-------------|-----------|------------|
| 9-1/2 or 10 | 15" x 15" | 209 sq in  |
| 15          | 18" x 18" | 313 sq in  |
| 20          | 21" x 21" | 418 sq in  |
| 25          | 23" x 23" | 523 sq in  |
| 30          | 25" x 25" | 627 sq in  |
| 40          | 29" x 29" | 837 sq in  |
| 50          | 33" x 33" | 1046 sq in |

#### 3. Additional Ventilation

The above chart shows vent sizes for one gas fired boiler.

If there is other equipment in the room that uses air (large water heaters, air compressors, other boilers, exhaust fans, etc.), additional venting capacity is required.

## E. Stack

### 1. Specifications

Install all stacks in compliance with state and local codes. **Lattner recommends double wall stack per ANSI Z21.13, appliance category III** for positive vent pressure systems. .

### 2. Stack Size

The entire stack must be the same size as the stack outlet on the boiler or one size larger. If the boiler stack is connected to other equipment, the stack size must be increased. **NOTE:** Any equipment with a forced draft burner must be vented separately from equipment with atmospheric burners. **NEVER** tie these stacks together.

### 3. Connections

Limit connections to one of the following combinations:

- Two 90 degree elbows,
- One 90 degree elbow and one tee,
- One 90 degree and two 45 degree elbows, or
- Four 45 degree elbows.

### 4. Overall Length

Avoid long runs of stack. A general rule is not to exceed 15 feet for every inch of stack diameter. For example, if the stack is 6" in diameter then the overall stack should not exceed 90 feet in length and height combined.

### 5. Horizontal Stack

Avoid any horizontal runs of stack. If unavoidable, horizontal runs should have a minimum incline of 3" per foot. If a long horizontal run (4 feet or more) cannot be avoided, a draft inducer may be required to properly vent combustion gases.

### 6. Draft Regulation

**LATTNER REQUIRES A NEGATIVE STATIC PRESSURE RANGE OF -0.10" WC TO 0" IN THE STACK FOR POWER BURNERS. THE BOILER ROOM SHOULD HAVE A SLIGHT POSITIVE PRESSURE.** A mechanical draft regulator should be used to control the pressure.

### 7. Walls & Ceilings

When passing through combustible walls or ceilings, a stack thimble is required. The thimble must be double wall stack, 6" larger in diameter than the vent stack. The material used to close the opening between the stack and the stack thimble must be non-combustible.

## F. Re-assemble Boiler Controls..

## 1. Wiring

Re-wiring the controls will be covered in **L: Electrical Connections**. **DO NOT** connect the power supply at this time.

## G. Steam Outlet

### 1. Pipe Size

Size steam pipe according to system requirements.

### 2. Outlet Size

Refer to product literature sheet for steam outlet size on a particular boiler model.

### 3. Steam Stop Valve

Install a steam stop valve in the steam line as close to the boiler as is practical. This allows boiler to be isolated from the system during service work and may be helpful in throttling steam flow. Required by ASME Code if the boiler is operated over 15 psi. Valve shall be rising stem or gate type valve.

### 4. Steam Piping

Steam line should be pitched downward away from the boiler and toward a steam trap. If using a steam solenoid valve, the steam line should slope upward slightly to the solenoid valve, and after the solenoid valve, the steam line should slope downward.

### 5. Code Standards

Piping must comply with all industry standards (ex. ANSI B31.1) and all state and local codes.

## H. Blowdown Piping (See diagram below)

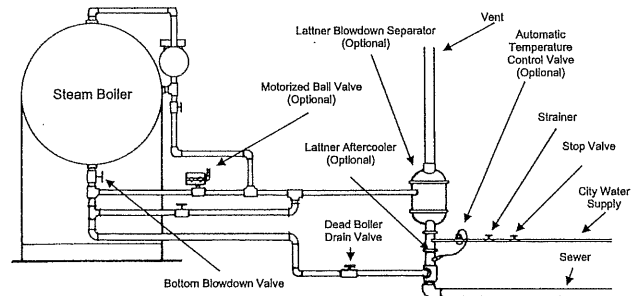

### 1. Boiler Bottom Blowdown

**DO NOT REDUCE.** Blowdown piping and all fittings must be the same size as the boiler blowdown connection (refer to product literature sheets).

Low pressure boilers, operating at 15 psi or less, require one blowdown or drain valve. The pressure rating of the valve must be equal to or greater than the pressure of the boiler safety valve but not lower than 30 psi.

Boilers operating 16 psi to 100 psi inclusive require a y-type gate or a ball valve rated for 125 WSP.

Boilers operating 101 psi to 150 psi require piping designed for a pressure of 125% of the boiler safety valve set pressure (schedule 80 blowdown piping), one quick opening, and one slow opening blowdown valve. If cast iron, these valves must be class 250, or if steel, these valves must be class 150, or if bronze, a WSP rating of at least 200.

Standard globe valves that form a pocket inside the valve are not acceptable blowdown valves. Y-type, gate, and ball valves are acceptable blowdown valves.

Galvanized piping is **not acceptable** for boiler blowdown piping.

## 2. Automatic Bottom Blowdown

A Lattner automatic bottom blowdown valve may be used in place of one of the manual blowdown valves.

## 3. Control/Water Column Blowdown

A water column level control is supplied with drain valve. Connect the control line to the bottom blowdown line **after** the second bottom blowdown valve.

## 4. Blowdown Discharge

All boiler blowdown water must be discharged to a safe location, specifically to a blowdown separator.

## 5. Blowdown Separator

Select a Lattner blowdown separator according to the size of the boiler blowdown connection.

| Blowdown Connection | Separator Model |
|---------------------|-----------------|
| 1"                  | 810             |
| 1-1/2"              | 1450 or 1455    |
| 2"                  | 1600            |
| 2-1/2"              | 1800            |

## 6. Inspection Opening

The extra coupling in the separator vessel is an inspection opening. The inspection opening will be plugged.

## 7. Vent

The blowdown separator must be vented to atmosphere. Vent pipe must discharge through the roof outside.

**DO NOT** reduce the vent pipe size. **NEVER** connect the vent pipe from the condensate tank to the separator vent.

## 8. Separator Drain

The water leaving the separator through the drain should be piped to the sewer. Some codes require the water to pass through an air gap before entering the sewer.

## 9. Aftercooler

If the water must be cooled before entering the sewer (required by some codes), then an aftercooler must be used. The aftercooler attaches to the separator drain connection and mixes cold water with the hot drain water. Units may be either manual or automatic. Select the aftercooler according to separator drain size.

| Separator | Manual | Automatic |
|-----------|--------|-----------|
| 810       | 205M   | 205A      |
| 1450,1455 | 301M   | 301A      |
| 1600      | 525M   | 525A      |
| 1800      | 625M   | 625A      |

## 10. Cooling Water Supply

Connect cold water supply pipe to aftercooler.

## 11. Dead Boiler Drain Valve

For draining the boiler when it is cool and not under pressure, the entire drain line must be lower than the bottom of the boiler. Pipe to sewer or floor drain. Valve must be rated up to the maximum allowable working pressure of the boiler.

## 12. Codes & Standards

All blowdown piping, drain and sewer connections, water piping and separator connections must be done in strict compliance with all applicable codes.

## I. Safety Valve

### 1. Installation

Be sure safety valve is threaded securely into the boiler or into the elbow supplied with boiler. The safety valve will always be installed in the upright position

### 2. Discharge

Pipe the safety valve outlet to a safe point of discharge. **DO NOT** reduce the safety valve discharge piping. **NEVER** plug the safety valve outlet.

### 3. Supports

Safety valve piping should be secured by clamps or braces to a wall or structural member. Do not allow the discharge piping to hang on the safety valve.

### 4. Codes & Standards

All safety valve piping and supports must conform to all applicable codes.

## J. Gas Train Piping

### 1. Components

In general, a gas train should include a manual gas cock, a main gas pressure regulator, a main gas valve, a safety shut-off gas valve, a pilot gas pressure regulator, a pilot gas valve, and a flame failure control.

## 2. Diaphragm Gas Valve

This valve is the main gas valve. A separate gas pressure regulator must be used to regulate main burner pressure.

## 3. Motorized Gas Valve

With the motorized gas valve, the main gas valve and pressure regulator are two separate components. The motorized gas valve is a two-piece valve. The lower section is the valve body, which is a plunger valve. The upper section is the actuator. The actuator has a small built-in hydraulic system. The hydraulic system opens and closes the valve. The motorized gas valve is a gas valve only, and has no other functions. This gas train requires a separate main gas pressure regulator, pilot gas pressure regulator and pilot valve.

The boiler will be supplied with a Honeywell flame safeguard control and an ignition transformer. With these controls, the boiler will have a spark-ignited pilot. This system will shut off the main and pilot gas within four seconds of a pilot failure.

**NOTE:** For additional information on the gas train refer to the assembly prints and product literature sheets (power burner manual included).

## 4. Gas Supply Pipe

The gas pipe to the boiler must be at least the same size as the gas train supplied with the boiler. **DO NOT** reduce.

## 5. Drip Leg

Gas supply piping must be installed with a proper drip leg ahead of any gas train components.

## 6. Gas Supply Pressure

Natural Gas: Supply pressure should be between 6" to 11" water column ahead of the gas pressure regulator. Minimum supply pressure when the boiler is operating should be 4-1/4" to 4-1/2" water column.

Liquid Propane: Gas supply pressure is normally 11" water column.

**WARNING: NEVER** use Teflon tape on any part of the gas train piping. This will void any warranty on the gas train assembly.

## 7. Codes & Standards

All gas piping must be done in accordance with all applicable codes (National Fuel Gas Code, utility company requirements, local building codes etc.).

## K. Boiler Feed Systems

### 1. Condensate Return Systems

### a. Make-Up Water Supply

Connect city water line to the float valve provided with the boiler feed system.

- LV5 through LV35 use 1/2" NPT
- R1-Jr through R5 use 1/2" NPT
- LV60 through LV100 use 3/4" NPT
- R7 through R12 use 3/4" NPT

Install a manual shut-off valve in the water line.

### b. Pump Suction Line

This is pre-piped from the factory with an isolation valve and strainer.

### c. Pump Discharge Line

**DO NOT** reduce. Use 1" NPT pipe and fittings between pump and boiler. Install two spring-loaded check valves. Install a hand shut-off valve between the last check valve and the boiler. Keep the number of elbows and fittings to a minimum.

### d. Condensate Return Vent

Condensate return tank must be properly vented to atmosphere. Vent should discharge through the roof or through a wall to the outside. Do not reduce the vent pipe size.

- LV5 through LV35 use 1" NPT
- R1-Jr through R5 use 1" NPT
- LV60 through LV100 use 1-1/2" NPT
- R7 through R12 use 1-1/2" NPT

### e. Overflow

Pipe to floor drain. Overflow connection should be at least as large as the condensate return.

### f. Drain Connection

Pipe to floor drain. Install a valve in the line. 1" NPT line is sufficient.

## 2. Solenoid Water Valve

### a. Water Pressure

This system will work only if the water supply pressure is at least 10 psi higher than the boiler pressure.

### b. Water Inlet

Refer to the boiler assembly print for correct connection and location of feedwater inlet.

### c. Piping

The solenoid water valve assembly shall be piped in the following order: Y-type strainer, solenoid valve, spring loaded check valve, globe valve, and

boiler. All pipe is 1/2" NPT.

#### **d. Water Supply**

Connect water supply to the strainer.

### **L. Electrical Connections**

**CAUTION:** All electrical work shall be done by a competent electrician. All wiring must be done in strict accordance with the National Electrical Code and any state or local codes.

#### **1. Reconnecting Controls**

If the boiler was shipped with controls removed, re-connect the wires according to the wiring diagram. All wires that need to be reconnected will have a tag indicating the control or terminals to which they must be connected.

#### **2. Electrical Supply**

Supply 120 volt single phase from a separate fused disconnect.

Use a 15 amp circuit breaker or fused disconnect if the boiler has a solenoid water feed valve or a pump motor 1/2 hp or less or a motor starter for a three phase pump.

Use a 20 amp circuit breaker or fused disconnect if the boiler has a 3/4 hp pump motor, 120 volt single phase.

#### **3. Power Supply**

Connect the power supply to the terminals in the panel box as shown on the wiring diagram. "Hot" side will be marked L1. Neutral will be marked L2.

#### **4. Secure Connections**

After all wiring is complete and before any power is supplied to the boiler, be sure all wiring connections are tight.

### **M. Before Firing The Boiler**

#### **1. Spare Fittings**

Check that all unused pipe nipples are plugged or capped.

#### **2. Float Block**

Remove the float block screwed into the body of the McDonnell Miller level control. Replace with a malleable iron plug (supplied with the boiler).

#### **3. Condensate Return System**

Make sure there is make-up water supply to the tank. Make sure there is water in the tank.

#### **4. Turn On**

Turn on the pump switch. Pump or solenoid valve should start immediately. If not, see troubleshooting section.

### **5. Check for Leaks**

While the boiler is filling, check for leaks in the piping and around boiler. If there are leaks, turn off the pump switch and fix all leaks before continuing.

### **6. Solenoid Feedwater Valve**

If a solenoid water valve is used, make sure the water supply is connected.

### **N. Pressuretrols: Controller & Limit**

#### **1. Standard**

All Lattner steam boilers will have at least two pressure switches, a "controller" and a "limit".

#### **2. Controller**

Before the boiler is started, the steam pressure is 0 psi. At this point, the controller is in the "ON" condition and is calling for heat. When the boiler switch is turned on, the boiler will fire and start generating steam. As the boiler fires, the steam pressure will rise. When the steam pressure reaches the controller's set point, the controller will shut off the burner. As steam is used, the pressure will begin to drop. When steam pressure drops enough, the controller will start the burner again. The controller will continue to operate in this manner to maintain boiler pressure.

#### **3. Setting The Controller (see diagram next page)**

On the left side of the pressuretrol is the set point indicating scale labeled "MAIN". Turn the main scale adjustment screw until the set point indicator aligns with the desired operating pressure. Turn screw clockwise to increase pressure, counterclockwise to decrease pressure.

#### **4. Differential**

When the boiler pressure reaches the main set point the controller shuts off the burner. The pressure must drop by a set amount before the controller will turn on the burner again. This amount is called the differential. The differential is adjustable.

#### **5. Setting The Differential (see diagram next page)**

On the far left side of the pressuretrols is the differential indicating scale labeled "DIFF". Turn the differential adjusting screw until the indicator aligns with the desired differential. A minimum differential will maintain the boiler pressure closer to the set point. A larger differential will help prevent rapid on and off cycling of the boiler.

#### **6. Limit**

The limit switch is similar in operation to the controller but has a slightly higher set point. If the controller fails to shut off the boiler and the steam pressure continues to rise, the limit switch will shut down the boiler. The controller is an operating switch; the limit serves as an

auxiliary safety cut-off. The limit switch is supplied with a manual reset function. If the steam pressure trips the high limit switch, the limit locks in the off position. The limit switch will not reset until the manual reset lever is pressed.

### 7. Setting The Limit (see diagram below)

This is done using the same procedure as for the controller. The limit setting will be slightly higher than the controller's set point.

Low pressure boilers (less than 15 psi): Set the limit switch 4 psi higher than the controller and 3 psi lower than the safety valve setting.

High pressure boilers (greater than 15 psi): Set the limit switch at least 10 psi higher than the controller and 5 psi lower than the safety valve setting.

### 8. Night Operating Pressure Switch

A third pressure switch may be supplied as an option. This switch allows the boiler to operate at low pressure at night for heating the building. Set the night operating pressure switch at approximately 10 psi.

### 9. Example

Boiler with a 100 psi safety valve. Set the controller at 80 psi with an 8 to 10 psi differential. Set the limit switch at 90 psi. Turn on the boiler, burner will fire. When the steam pressure reaches 80 psi, the controller shuts down the burner. When the pressure drops to 70 to 72 psi the burner restarts. The boiler continues to cycle to maintain 80 psi. If for some reason the steam pressure should rise to 90 psi, the limit switch shuts off the boiler. The manual reset on the limit switch must then be reset before the boiler will operate again.

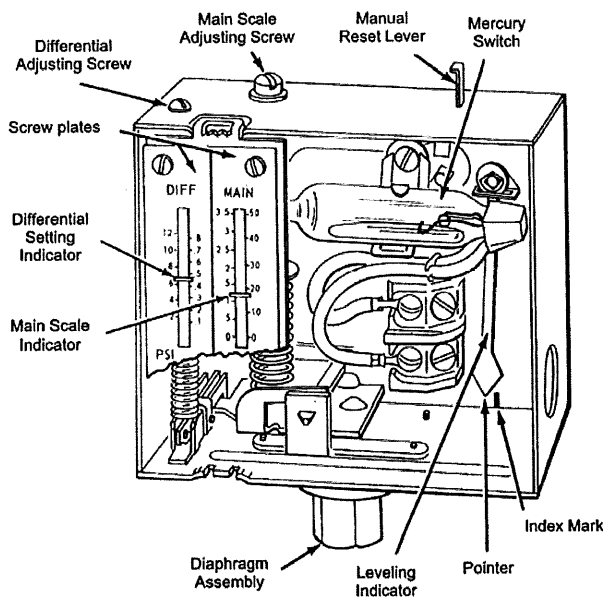

### 10. More Information

For any additional information on the Honeywell Pressuretrols, refer to the Honeywell product sheet in the back of this manual.

### O. Start Up of Standard Burners

**CAUTION:** All work performed on gas fired equipment or gas train components must be done by qualified personnel.

1. Turn boiler switch OFF
2. Purge gas line
3. Turn OFF the main gas supply cock
4. Turn ON the pilot supply gas cock
5. Turn boiler switch ON
6. Burner fan will initiate a pre-purge sequence followed by ignition of the pilot
7. Main gas valve will energize and open but will not fire
8. Check pilot for adequate flame signal (2.0 mV minimum)
9. Slowly open main gas cock to allow main burner to light
10. If everything is normal, then adjust the main gas pressure regulator for proper pressure as shown on the burner "As Built" specification sheet
11. Turn OFF boiler switch
12. Turn ON boiler switch
13. Check for proper burner ignition

Refer to the burner manufacturer's installation manual for more specific burner start up instructions.

**\*For warranty validation, complete start up check list (included with boiler) and return it to Lattner. Failure to return check list may void warranty.**

### 14. Burner Head Pressure

Check gas pressure at burner head. Burner head pressure should be as specified in the burner manual.

### 15. Adjust Pressure

If the burner head pressure is not within that range, adjust the gas pressure regulator. Remove large slotted cover screw and turn the adjusting screw underneath. Refer to Maxitrol product sheet for complete instructions.

## 16. Check for Gas Leaks

Brush a soapy water solution on each connection in the main gas and pilot gas lines. Look for bubbles. If there are any gas leaks, shut off the main gas supply and fix any leaks before continuing. Repeat steps 1 through 6. Do not use a match or other types of fire to locate a gas leak.

## 17. Adjust The Burners

Forced draft burners can only be properly set up by using combustion test equipment. These burners cannot be set up on how the flame looks. Refer to the burner manual in the product literature section for proper carbon monoxide, carbon dioxide, and excess oxygen levels.

## 18. Burning Tuning Objectives

The following measures are approximations only. Data may vary by location, environment, fuel, gas pressure, BTU content and more. **REFER TO BURNER NAMEPLATE AND BURNER MANUAL FOR MORE SPECIFIC INSTRUCTIONS**, including low-NO<sub>x</sub> burner instructions for California and Texas.

| Constituent           | Value                    |
|-----------------------|--------------------------|
| Required Gas Pressure | Maximum 14" w.c.         |
| Required Gas Pressure | Minimum varies by burner |
| Manifold Pressure     | See burner nameplate     |
| O <sub>2</sub>        | 4.5% to 7.5%             |
| CO <sub>2</sub>       | 8% to 10%                |
| CO                    | Less than 100 ppm        |
| NO <sub>x</sub>       | Less than 60 ppm         |
| Stack Temperature     | 425°F to 475°F           |
| Efficiency            | 80% to 83%               |

## 19. Pressuretrols

Allow the boiler to reach its operating pressure. Check the pressuretrols to be certain they're are set as described and functioning properly.

## 20. Level Controls

Make certain the level control feeds water into the boiler and maintains a proper water level.

## 21. Odor

It is normal for a new boiler to give an odor when it first fires. This odor will generally go away within two days.

## Section II: Boiler Care

**CAUTION:** Read and follow all instructions before servicing any boiler.

---

### A. General

The life expectancy of any boiler will depend on the routine care given to the boiler. The condition of the water inside the boiler is probably the most important single factor in determining the life of the boiler. The new boiler must be cleaned, proper water treatment must be used over the life of the boiler, and a regular blowdown schedule must be followed. To ensure continuous reliable operation, it is also important that the water feed system be maintained, the burners operate correctly, and the boiler be inspected periodically.

### B. New Boiler Clean Out

#### 1. Purpose

Regardless of the care used in the manufacture of steel boilers, a certain amount of oil, grease and pipe dope will still be in the boiler when shipped from the factory. Oil in a boiler can cause water to foam and bounce. This creates an unstable water line and causes water to carry over in the steam lines. To remove oil and grease from a new boiler, use the supply of Lattner Boiler Compound sent with the boiler.

#### 2. Directions

When installation is complete and boiler has been filled with water, remove the safety valve or use any capped or plugged opening above the water line. Pour in a mixture of Lattner Boiler Compound with water. Follow instructions on the label of the boiler compound and use initial dose as outlined. Fire the boiler and maintain steam pressure of at least 20 psi for a minimum of two hours. This permits the boiler compound to cook and loosen the oil and grease from all metal surfaces. Then shut off the boiler switch, allowing the boiler to cool for one hour and the steam pressure to drop to 0 psi. Open the blowdown valve to the wide open position allowing all water and steam to be blown out of the boiler. Allow boiler to cool to approximately room temperature before filling with cool water.

When using a condensate return system with a boiler, it is advisable to waste all of the condensate for the first day or two. This will keep the oils not taken care of by the boiler compound from going back through the pump and into the boiler. If this is not possible then the new boiler clean out procedure becomes imperative.

**NOTE: Never fill a hot, empty boiler with cold water.**

### C. Water Conditions

#### 1. Oxygen Scavenging

The oxygen will then attack exposed metal surfaces. This leads to corrosion and localized pitting of the metal.

### 3. Scale Deposits

As the water boils, the dissolved minerals will separate from the water and attach to the boiler shell forming scale deposits. Scale will deposit on all surfaces below the water line. Scale deposits will plug the piping and damage the controls.

Layers of scale on the boiler shell act as an insulator, preventing heat transfer to the water. This will lower the boiler efficiency and cause the boiler shell to retain heat. Overheating the boiler shell will cause permanent damage to the pressure vessel.

Scale deposits inside the boiler can retain enough heat to cause the pressure to continue to rise after the burner is shut off. The pressure may rise enough to lift the safety valve.

### D. Water Treatments & Chemicals

#### 1. Purpose of Water Treatment

Water treatment chemicals are added to the boiler water to prevent the damaging effects of scale and oxygen corrosion. A complete chemical treatment program must also control the pH level in addition to providing both an oxygen scavenger and control of dissolved solids. The chemicals react with the dissolved solids and dissolved oxygen. This prevents the solids and the oxygen from attacking the boiler.

#### 2. Selecting Water Treatment

The boiler feedwater should always be tested by a competent water treatment company that can analyze the boiler water and recommend the best water treatment program for the boiler based on water quality. Some water treatment companies will ask for more samples after the boiler has been in use, to make sure that the water treatment used is adequate. There are several competent water treatment companies that can test, analyze, recommend and supply a boiler feedwater treatment program.

### E. Water Softener

A water softener by itself is not a complete treatment program. A softener controls a substantial portion of the dissolved solids. However, it does not remove dissolved oxygen nor does it control the pH level.

Never use zero grain soft water without additional chemical

Generally, boiler feedwater will contain oxygen and dissolved minerals. Inside the boiler, the heat will cause the oxygen to separate from the water.

treatment. Whenever a softener is used, chemical treatment is still necessary for oxygen scavenging and controlling pH.

## F. Foaming, Bouncing, & Carryover

### 1. Causes of Foaming

It is normal for the water line of Lattner boilers to fluctuate about one inch. However, excessive foaming and bouncing (an unstable water line) can be caused by several different conditions. The presence of oil or grease in the boiler water will cause serious foaming. Foaming can also be caused by excessive concentrations of boiler water solids. A third cause is excessive alkalinity (high pH level). Water that's too soft will also cause the water level to bounce.

### 2. New Boiler Foaming

In a new boiler, foaming has two primary causes. Oil from the steam piping and the boiler metal has accumulated at the water line. Secondly, Lattner clean-out compound contains trisodium phosphate. This must be thoroughly flushed out of the boiler. Trisodium phosphate, if left in the boiler, will raise the alkalinity, causing foaming.

### 3. Carryover

Carryover (often called priming) is small droplets of water leaving the boiler with steam. Foaming, as described before, is a key cause of carryover. If the foaming problem is eliminated, the carryover should stop as well. If the system uses steam faster than the boiler can make steam, water carryover may occur as well. Be certain that all steam traps function properly, all piping is insulated, there are no leaks in the steam piping, and the burner combustion is set properly.

## G. Water Treatment Summary

These are general guidelines for water treatment. Lattner is not a water treatment company and cannot make specific recommendations for each boiler installation. To ensure proper operation and extend the life of the boiler, a complete water treatment program must be used. Contact a qualified company with experience in this field to provide a treatment program for your installation. Insufficient or too much chemical treatment can damage your boiler. The following are guidelines for boiler water quality:

| Constituent            | Value                              |
|------------------------|------------------------------------|
| pH                     | 8.5 to 10                          |
| Total Dissolved Solids | 2,000 ppm or 116.8 grains maximum. |
| Oxygen                 | 0 ppm                              |
| Alkalinity             | Less than 300 ppm                  |
| Chloride               | Less than 500 ppm                  |
| Sodium Phosphate       | Less than 100 ppm                  |

## H. Blowdown

### 1. Purpose of Blowdown

The water treatment chemicals keep these substances suspended in the water. Eventually, the concentration of these substances increases and must be removed. This is done by blowdown. Blowdown removes a portion of the water in the boiler in order to reduce the amount of dissolved solids. Blowdown will also remove some of the loose deposits that may be in the boiler.

### 2. Blowdown Instructions

The boiler may be blown down at any pressure, provided the blowdown piping is piped to a safe location (see Installation Instructions). To blowdown, open the boiler bottom blowdown valve (see assembly print) to the fully open position. Watch the sight glass. When the boiler water level drops about one inch, close the blowdown valve. Lattner recommends 30 psi.

**NEVER** blowdown a hot boiler to a level where no water is visible in the sight glass.

### 3. Control Blowdown

Scale can also deposit in the water level controls and piping, just as it can deposit in the boiler. The McDonnell Miller level control and auxiliary low water cut-off water column **MUST** also be blown down daily. If scale blocks these controls or the piping connected to them, the boiler may dry fire. Dry-firing the boiler will permanently damage the boiler shell.

## I. Feedwater System

### 1. General

A boiler cannot operate without water. For proper operation, the boiler must have a reliable water supply.

### 2. Pump Cavitation

Always use spring-loaded check valves in the feedwater piping. Swing check valves (even when new) are not suitable for boiler feed applications.

A bad check valve will allow hot water from the boiler to back-feed to the pump. When the pump starts, this water flashes to steam. This condition, known as cavitation, causes the pump to sound like there are ball bearings in the water and prevents the pump from working properly, especially when the boiler pressure rises.

Bad steam traps may also cause the pump to cavitate. Bad traps allow steam to return to the condensate tank and heat the water in the tank. As the water temperature gets above 180° F, cavitation becomes more likely and prevents the pump from working properly.

### 3. Check Valves & Steam Traps

To check for bad steam traps or check valves, look at

The boiler and the boiler level controls should be blown down at least **DAILY**.

A thermal sensor may be used to help detect which traps are malfunctioning.

## **J. Burner Adjustment**

### **1. Danger**

Only competent personnel familiar with forced draft burners and having proper test equipment to measure burner input and analyze flue gases should attempt adjusting the burner. Refer to the burner manual for proper settings of the forced draft burner.

### **2. Insufficient Air**

A properly adjusted burner will burn with an orange-blue flame. If the flame burns brilliant yellow, incomplete combustion is occurring. A yellow flame will deposit soot on the boiler heating surfaces and decrease efficiency. A yellow flame in general terms is caused by too much gas or too little air. Check burner adjustment, air supply to the room, proper gas pressure, draft conditions and the actual gas input according to the gas meter.

### **3. Excess Air**

In adjusting the burner air shutters, it is also important not to open them too far. Too much air will cause the burners to backfire when lighting. When burners backfire, they frequently extinguish the pilot flame. This will shut down the boiler. Additionally, when there is excess combustion air, efficiency declines. Heat is wasted warming the excess air instead of making steam.

## **K. Sight Glass**

### **1. Maintenance**

The sight glass and water gauge set must be properly maintained in order to observe the boiler water level. Open the bottom drain cock (on the lower sight glass fixture) periodically to flush scale and sediment out of the sight glass.

### **2. Regular Placement**

Replace the sight glass about every six months with new gaskets and brass washers. The continual movement of water through the water gauge set wears the sight glass. The combined effects of wear and high pressure cause small cracks to develop in the sight glass over a period of time. Eventually the sight glass will shatter. This is avoided by replacing the sight glass regularly.

### **3. Gaskets & Washers**

When installing a new sight glass, also replace the gaskets and brass washers. If the brass washers are not in place, the gasket will twist, causing the glass to break.

### **4. Proper Installation**

the vent pipe from the condensate return tank. If there is an abnormally high steam flow from the vent, either the traps or check valves are leaking.

## **L. External Inspections**

### **1. Maintenance**

External inspections are routine observations of the visible portions of the boiler. By noticing the normal boiler operation, many problems can be detected before they become serious.

### **2. Piping**

Check the piping for leaks. This includes steam pipes, condensate pipes, feedwater pipes, blowdown pipes and all fittings on the boiler. If leaks are found, tighten the fittings or connections. If the pipe threads show extensive corrosion, replace the section of pipe. Remember, **NEVER** use galvanized pipe for a steam system or for condensate lines.

### **3. Dust & Debris**

If dust, lint, or other debris collect on and around the boiler, then use pressurized air or a rag to clean the exterior surfaces. Also, it is very important to remove dust and debris that accumulate inside the boiler panel box. When working in and around the panel box always shut the power off at the circuit breaker or disconnect switch (do not use the boiler switch). Use an air hose to blow out the panel box and controls.

### **4. Safety Valve**

Check that steam is not leaking from the safety valve. If the safety valve is not seating properly, then replace it with a new valve.

### **5. Level Controls**

When making an external boiler inspection, it is also necessary to inspect the McDonnell Miller and auxiliary low water cut-off level controls. Disassemble the McDonnell Miller control per instructions in the Maintenance section. Check for scale build-up in the float chamber, around the float ball and the float rod. Check the float for leaks. Hold the float completely submerged in a bucket of water and look for air bubbles. If the float leaks or is damaged, it must be replaced. Remove the auxiliary low water cut-off probe and remove any scale that has deposited on the probe. **Important:** Inspect and clean **all** interconnecting piping on the auxiliary low water cut-off and the McDonnell Miller.

### **6. Surface Rust**

Occasionally sheet metal surfaces will rust, especially near the stack. Water, a normal product of combustion, and the high temperatures present will cause rust. Perchloroethylene, used in dry cleaning, will accelerate corrosion. Check the entire length of the stack to be sure there is no leakage of combustion gases. Any rust appearing on the boiler jacket will only affect the boiler's appearance and should not harm the boiler operation.

Always be certain the sight glass is cut to proper length. Make sure the fixtures are plumb. If these two conditions are not checked, the glass may crack.

## **M. Internal Inspections**

### **1. Purpose of Inspections**

Internal boiler inspections are required to check the structural integrity of the boiler shell and look for scale accumulations inside the boiler.

### **2. New Boiler Inspection**

Make the initial inspection of a new boiler within 30 days of start-up. Depending on the condition of the boiler at this time, have a second inspection in six months or less. The results of these internal inspections can be used to set a time interval for future internal inspections.

### **3. In Service Boilers**

The time between inspections will vary from 180 days to one year. This depends on the amount and the quality of the boiler feedwater, and also on how the boiler is being used. If the boiler uses large quantities of untreated hard water, the boiler may need to be inspected every 60 days. If the boiler uses minimal quantities of make-up water (i.e., closed loop systems) and the water is treated, the boiler may need to be inspected only once a year. Many state and/or city codes require annual internal boiler inspections.

## **4. Gaskets**

The hand hole gaskets and the McDonnell Miller head gasket must be replaced after each internal inspection. If any leaks are present around the gasket surfaces, replace the gasket immediately. High pressure water and steam leaks will erode the metal surfaces and cause damage to the boiler which will require expensive repairs. Keep a full set of hand hole gaskets and a McDonnell Miller head gasket in stock at all times.

## **5. Sight Glass**

A sight glass with gaskets and washers should be kept in stock. Replace the sight glass with new gaskets and washers.

## **6. Routine Service**

These standard maintenance items are considered routine and are not covered under warranty.

## Section III: Maintenance

**WARNING:** All maintenance procedures must be followed completely by competent personnel familiar with boilers and boiler accessories.

**CAUTION:** Read and follow all instructions thoroughly before working on any boiler equipment.

**NOTE:** Certain maintenance items concerning specific components may be found in the product literature specifications section of this manual.

---

### A. Daily Blowdown

The boiler and controls may be blown down at any pressure but the blowdown lines must be piped to a safe location. Lattner recommends blowing down at 30 psi.

#### 1. Boiler Blowdown

- Turn the boiler blowdown valve to the full open position.
- Watch the sight glass. Let the water drop one inch in the sight glass. Approximately 10 to 12 seconds.
- Shut the boiler blowdown valve.

#### 2. McDonnell Miller/Water Column Blowdown

- Turn the McDonnell Miller blowdown valve to the full open position.
- Leave the valve open for 3 to 5 seconds.
- Shut the water column blowdown valve.

#### 3. Auxiliary Low Water Blowdown (if applicable)

- Turn the auxiliary low water column blowdown valve to the full open position.
- Leave the valve open for 3 to 5 seconds.
- Shut the low water column blowdown valve.

### B. Weekly Maintenance

1. Check the sight glass for excessive wear or leaks.
2. Test the McDonnell Miller and auxiliary low water cut-off for proper operation. By opening the blowdown valves with the boiler firing, the burners must shut off during this test. If the burners do not shut off, the control may require immediate servicing.
3. Drain the sight glass.
4. Visually inspect the boiler and water feed system for any water or steam leaks in the piping.
5. Check the vent pipe from the condensate return tank for excessive steam loss. This would indicate bad steam traps or check valves.

### C. General Maintenance (Refer to Table 1, Page 20)

1. Do the following every 6 to 12 months depending on water quality:
  - Remove hand hole plate and clean inside boiler.
  - Reassemble each hand hole with a new gasket.
  - Clean McDonnell Miller float chamber.
  - Reassemble the operating mechanism with a new head gasket.
  - Clean scale off the auxiliary low water cut-off probe.
  - Clean the interconnecting piping between the boiler and McDonnell Miller.
  - Clean the interconnecting piping between the boiler and auxiliary low water column if applicable.
2. Open the boiler for a complete internal inspection at least once a year.
3. Replace the sight glass with gaskets and washers every six months or less if signs of wear appear.
4. Rebuild or replace the check valves in the water feed line at least once a year. Always use spring-loaded check valves.
5. Inspect the pilot burner and flame scanner for soot or dirt accumulations.

**D. Table 1: Recommended Testing Schedule**

| Item                           | Frequency   | Responsibility     | Remarks   |
|--------------------------------|-------------|--------------------|---|
| Gauges and Sight Glass         | Daily       | Operator           | Make visual inspection and record readings in a log.  |
| Instrument and Boiler Settings | Daily       | Operator           | Make visual check against manufacturer's recommended specifications. Refer to product literature sheets.  |
| Low Water Fuel Cut-Off         | Monthly     | Operator           | Refer to manufacturer's instructions.   |
| Pilot and Main Fuel Valves     | Monthly     | Operator           | Make visual inspection.   |
| Flame Failure Response Time    | Monthly     | Operator           | Close manual fuel valve supply. Check safety shut-off timing. Log results.  |
| Flame Signal Strength          | Monthly     | Operator           | If appropriate equipment is installed to measure flame signal, read and log results for pilot flame. Notify service organization if readings are high, low, or fluctuating. |
| Hand Hole Plates               | Monthly     | Operator           | Visually check for leakage and replace gaskets as necessary.  |
| Firing Rate Control            | Annually    | Service Technician | Verify BTU input and gas pressure and check with combustion test/analyzer.  |
| Igniter or Pilot               | Annually    | Operator           | Make visual inspection and check flame strength with appropriate equipment.   |
| Flue, Vent, and Stack          | Annually    | Operator           | Make visual inspection and check for proper operation.  |
| Pilot Turndown Test            | Annually    | Service Technician | Required after any adjustments to pilot or gas pressure.  |
| High Limit Safety Control      | Annually    | Service Technician | Refer to product literature.  |
| Operating Control              | Annually    | Service Technician | Refer to product literature.  |
| Safety Valve                   | As Required | Operator           | In accordance with ASME Boiler and Pressure Vessel Code, "Recommended Rules for Care and Operation of Heating Boilers".   |

## E. Hand Hole Plate Removal & Re-Installation

1. Disconnect all power to the boiler.
2. The boiler must be cool and drained of all water.
3. See assembly print for hand hole location.
4. Remove the hand hole plate nut. Use a 7/8" socket.
5. Remove arch over hand hole plate.
6. Remove hand hole plate. Sometimes it is necessary to tap on the hand hole plate to loosen it. Make sure the hand hole plate does not fall inside the boiler.
7. Scrape the inside of the boiler around the hand hole area to remove any scale or old gasket material.
8. Scrape the old gasket material off the hand hole plate.
9. Make sure there are no burrs around the hand hole opening. Remove any burrs with a file.
10. Place the hand hole plate back into the boiler hand hole plate opening without the gasket. If the plate rocks back and forth, remove the high spots on the hand hole plate with a file. **Note: Do not leave the hand hole plate installed without the gasket.**
11. Install the gasket on the hand hole plate. Make sure the gasket is pressed firmly down on to the hand hole plate. **Do not use any grease, lubricants, or adhesives when installing handhold gaskets.**
12. Reinstall the hand hole plate into the boiler.
13. Replace the arch over the stud of the hand hole plate. The arch should extend across the width (short way) of the hand hole opening.

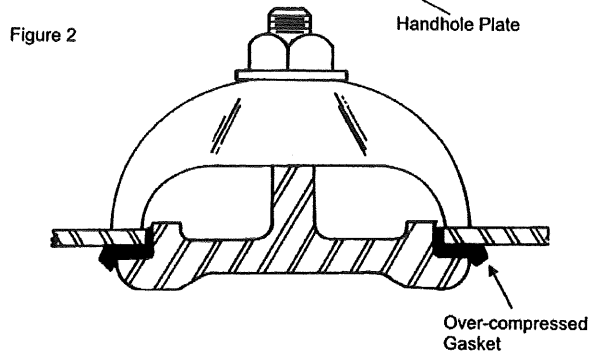
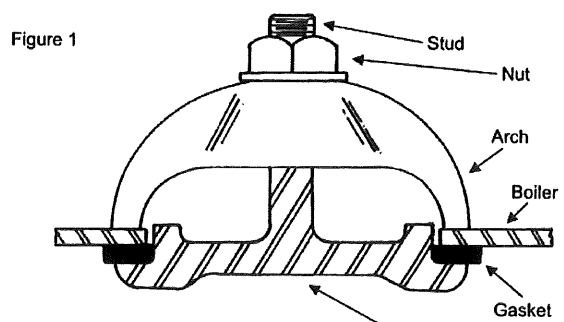

14. Replace the nut on the hand hole plate stud. Tighten the nut hand tight, then turn the nut  $\frac{1}{4}$  turn with a socket. **Do not compress the gasket excessively.** This will only shorten the life of the gasket.
15. Reconnect the power to the boiler.
16. Check the hand hole plate for leakage with pressure on the boiler. If leaks are noted, remove the pressure from the boiler, let the boiler cool and drain to reposition the hand hole plate. Repeat steps 12 through 16.

## F. Sight Glass Removal & Re-Installation

1. Boiler and pump should be switched off.
2. Boiler should be cool and the water level should be below the lower water gauge fixture.
3. Close the upper and lower water gauge valves.
4. Loosen both sight glass packing nuts (top and bottom) with a wrench.
5. Slide glass carefully upward into the upper fixture. Glass should lift out of the lower fixture.
6. Pull glass down, out of the upper fixture tilting the glass slightly to clear the lower fixture. Be careful not to break the sight glass when removing.
7. Assemble the new sight glass as shown. **ALWAYS** replace the gaskets and brass washers when installing a new sight glass.
8. Slide the new glass into the upper fixture. Glass should clear the lower fixture and tilt into position.
9. Slide the sight glass down into the lower fixture. Equalize the gap between the upper and lower fixtures.
10. Tighten the sight glass packing nuts hand tight.
11. Use a wrench to tighten 1/4 turn past hand tight. **NEVER** over tighten the sight glass. This will crack the glass and cause it to shatter under pressure.
12. Open the upper and lower gauge valves.
13. Switch on boiler and pump.

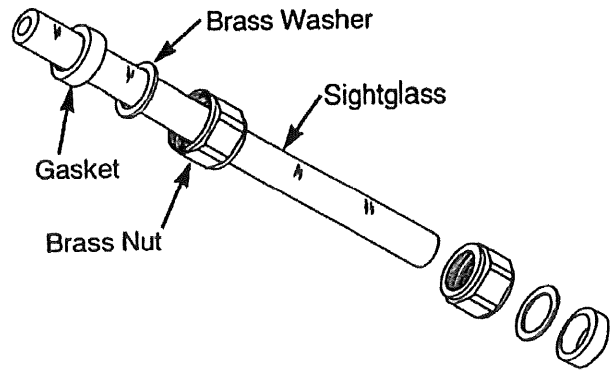

## G. McDonnell Miller Servicing

1. Disconnect all power to the boiler.
2. The boiler should be cool and drained of all water just below the McDonnell Miller control.
3. Make sure all water is drained from the McDonnell Miller control by opening the control blowdown valve.
4. Disconnect the wiring and conduit connection to the McDonnell Miller. Tag all wires to ensure they are reconnected properly.
5. Remove the eight bolts holding the operating mechanism to the McDonnell Miller body. Use a 9/16" wrench or a crescent wrench.
6. It may be necessary to tap near the base of the operating mechanism to free it from the body.
7. Lift the McDonnell Miller operating mechanism out of the body. Be careful to avoid damaging the float and float arm which extend into the body of the McDonnell Miller.
8. Carefully scrape the old gasket from the body and the operating mechanism of the McDonnell Miller.
9. Remove any scale in the McDonnell Miller body. Always check the operating mechanism for any scale that might be blocking the float or float arm.
10. Check the float for any holes. Hold the float submerged in a bucket of water and look for any air bubbles coming from the float.
11. Always reassemble the McDonnell Miller operating mechanism to the body with a new gasket.
12. Reinstall the eight bolts to the operating mechanism. Draw up the bolts evenly to prevent damage to the gasket, body or operating mechanism. Do not over tighten the bolts.
13. Reconnect the McDonnell Miller per wiring diagram.
14. Reconnect all power to the boiler.
15. Use a steel rod or a hard brush and clean inside of the piping.

16. Flush out all piping with water after cleaning.
17. Replace all pipe plugs and pipe caps. Tighten with a wrench enough to prevent water or steam leaks.
18. Reconnect power to the boiler.

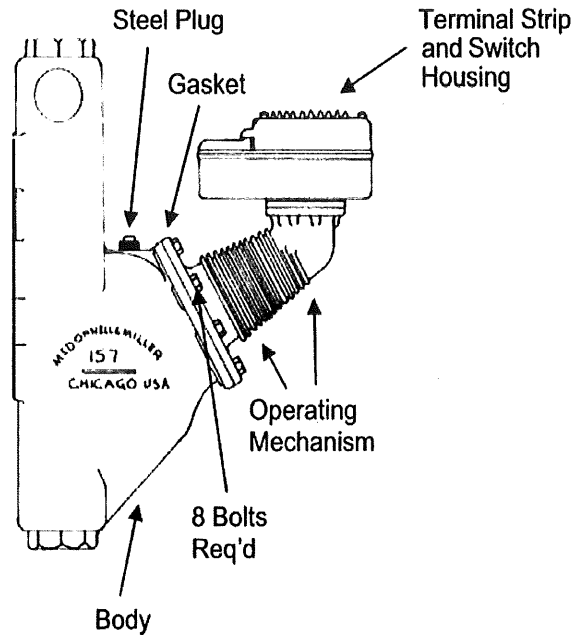

## H. Cleaning Interconnecting Pipe (McDonnell Miller)

1. Disconnect all power to the boiler.
2. The boiler must be cool and drained of water below the level controls.
3. Make sure all water is drained from the McDonnell Miller or auxiliary low water cut-off control by opening the blowdown valve.
4. Clean all interconnecting piping by removing the pipe plugs or pipe caps. Remove all 1" pipe plugs with a 13/16" wrench or a crescent wrench. Remove the pipe caps with a pipe wrench.

### I. Warrick Relay Replacement

1. Disconnect all power to the boiler.
2. Pull relay out by hand. This may take a little force but be careful.
3. Replace the Warrick with a new 26M series Warrick. The relay has a small tab so that it can be installed only one way.
4. Reconnect the power to the boiler.

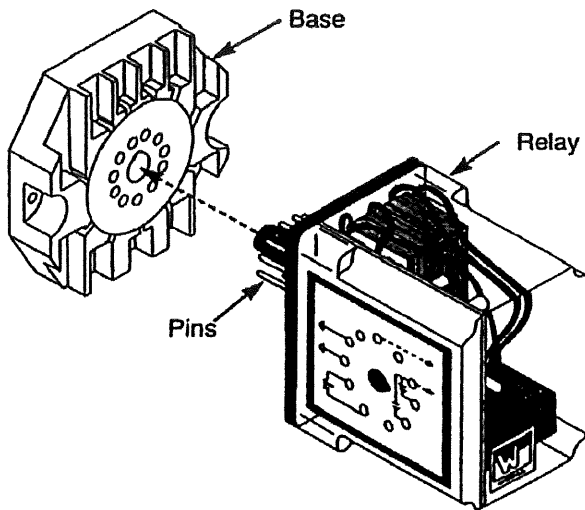

### J. Auxiliary Low Water Cut-Off Probe Cleaning

1. Disconnect all power to the boiler.
2. Remove the four screws on top of the probe enclosure with a Phillips screwdriver.
3. Remove the wire from the probe using a 5/16" wrench or a crescent wrench. Only the wire on the probe is to be removed.
4. Use a 13/16" spark plug socket and remove the probe.
5. Clean the stainless steel probe and probe fitting.
6. Reinsert the probe using a 13/16" spark plug socket. Only tighten the probe enough to stop any steam leaks. Over tightening will destroy the threads of the enclosure.
7. Reinstall the probe wire to the probe.
8. Reassemble the cover to the enclosure with the four Phillips screws.
9. Reconnect power to the boiler.

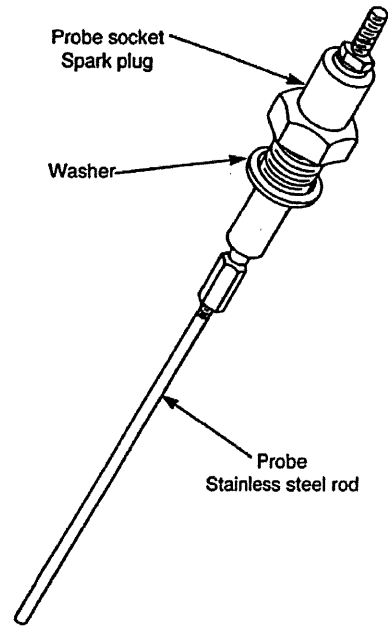

## Section IV: Troubleshooting

**WARNING:** All troubleshooting procedures must be followed completely by competent personnel familiar with boilers and accessories.

**CAUTION:** Read and follow all instructions before troubleshooting any boiler equipment.

---

### A. Normal Operation

All Lattner forced draft gas-fired boilers follow the same operating sequence:

1. Turn the pump switch ON.
2. McDonnell Miller pump control turns on the pump or solenoid water valve.
3. Pump or solenoid valve fills boiler.
4. McDonnell Miller shuts off the pump or solenoid water valve when water is at normal operating level.
5. Turn boiler switch to the ON position.
6. Gas valve opens and main burners light.
7. Boiler pressure will rise to the pressure controller's set point. The then controller will shut off the gas valve.
8. When the boiler calls for water, the McDonnell Miller level control will turn on the pump or solenoid water valve.
9. If the pump cannot fill the boiler, the McDonnell Miller low water cut-off will shut down the boiler. If the McDonnell Miller does not shut down the boiler, the auxiliary low water cut-off will shut down the boiler.
10. If the boiler has optional controls, refer to the wiring diagram.

### B. Basic Service Tools

The following basic equipment will aid in troubleshooting Lattner boilers. Not all equipment is needed for every repair:

1. Schematic diagram of the boiler
2. Volt/ohm meter
3. Ammeter
4. Gas pressure gauge
5. Flame simulator
6. Continuity tester
7. Flue gas analyzer
8. Carbon monoxide sampler

### C. Before You Begin

Before you begin any troubleshooting procedures, check the following:

1. Make sure the pilot is lit.
2. Be certain boiler switch is on and that there are 115 volts supplied to the boiler control circuit.
3. Be certain pump switch is ON and check for proper pump voltage and phase if different from boiler circuit.
4. Check if breaker is tripped or if fuse is blown.
5. Make sure there is water in the boiler.
6. Be certain manual gas cock is open and that gas is supplied to the boiler.
7. Be certain that all manual resets have been pushed.

**Note: All Lattner boiler controls are wired in series.** The boiler operating controls and limits form a series circuit. When all switches close, the boiler should fire.

| Possible Boiler Problems  | Possible Causes   |
|---|---|
| Boiler and pump switch are ON, pump does not run and low water level in boiler. | <ol style="list-style-type: none"> <li>1. Circuit breaker is tripped or fuse is blown.</li> <li>2. McDonnell Miller piping is plugged.</li> <li>3. McDonnell Miller float is stuck.</li> <li>4. McDonnell Miller is wired incorrectly.</li> <li>5. Pump or solenoid water valve is wired incorrectly.</li> </ol>  |
| Pump runs but does not maintain water level in boiler.                          | <ol style="list-style-type: none"> <li>1. Valve between boiler pump and boiler is closed.</li> <li>2. Bad check valve. Always replace check valves with spring-loaded check valves.</li> <li>3. Bad steam trap(s).</li> <li>4. Feedwater temperature is too high (pump is cavitating).</li> <li>5. Strainer is plugged.</li> <li>6. Pump isolation valve is closed.</li> <li>7. No water supplied to pump.</li> </ol>   |
| Pump or solenoid overfills boiler.  | <ol style="list-style-type: none"> <li>1. Solenoid water valve is not seating properly.</li> <li>2. McDonnell Miller float operating incorrectly (snap switches "sticking").</li> <li>3. McDonnell Miller mercury tube is malfunctioning.</li> <li>4. McDonnell Miller is wired incorrectly.</li> <li>5. Pump is wired incorrectly.</li> </ol>  |
| Boiler takes excessive time to reach pressure.                                  | <ol style="list-style-type: none"> <li>1. Burner is improperly adjusted.</li> <li>2. Improper gas pressure or insufficient supply of gas to boiler.</li> <li>3. Boiler flue passages need to be cleaned.</li> <li>4. Scale build-up inside boiler.</li> <li>5. Gas valves not operating properly.</li> <li>6. Pump not feeding enough water to the boiler.</li> </ol>   |
| Limit switch always shuts down boiler.  | <ol style="list-style-type: none"> <li>1. Operating pressure switch is set higher than limit switch.</li> <li>2. Scale build-up inside of boiler.</li> <li>3. Operating pressure switch (Honeywell "Controller") is not operating correctly.</li> </ol>   |
| Boiler shuts down on auxiliary low water cut-off.                               | <ol style="list-style-type: none"> <li>1. Pump switch is turned OFF.</li> <li>2. Probe wired incorrectly.</li> <li>3. Probe has scale, dirt, or debris on it.</li> <li>4. Probe not seated in probe socket properly.</li> <li>5. Auxiliary level control relay wired incorrectly.</li> <li>6. Foaming problem in boiler (possible chemical over treatment).</li> <li>7. Water in boiler is too soft (possible water softener over treatment).</li> <li>8. McDonnell Miller primary low water cut-off isn't operating properly.</li> <li>9. Pump is not functioning properly.</li> <li>10. Malfunctioning check valve. Always replace check valves with spring-loaded check valves.</li> <li>11. No water supplied to the pump.</li> </ol> |
| Burner fails to start.  | <ol style="list-style-type: none"> <li>1. Bad fuse or switch open on incoming power source or motor overload out.</li> <li>2. Control circuit has an open control such as operating, limit, or low water cut-off.</li> <li>3. Reset button on motor or flame safeguard programming control open (push reset button).</li> <li>4. Loose or faulty wiring. Tighten all terminal screws. Check wiring against wiring diagram furnished with burner.</li> <li>5. Regulator vent plugged.</li> </ol>   |
| Burner motor runs but pilot does not light.                                     | <ol style="list-style-type: none"> <li>1. Be sure gas is turned on at meter and pilot cock is open.</li> <li>2. Place hand on pilot valve to feel it open. Check gauge at tee in pilot line for gas pressure and prompt opening of pilot valve.</li> <li>3. Check visually or by sound for spark arcing.</li> <li>4. Check air switch. Be sure its circuit closes during start. Be sure timing card is inserted into flame safeguard.</li> <li>5. Bad igniter.</li> <li>6. Bad pilot solenoid valve.</li> <li>7. Pilot regulator vent plugged.</li> </ol>   |

|  |   |
|--|---|
| <p>Burner motor runs and pilot lights but main gas valve does not open.</p>  | <ol style="list-style-type: none"> <li>1. Check flame strength signal (digital display module). If low, adjust pilot gas pressure and air settings for improved readings.</li> <li>2. Possible dirty scanner lens.</li> <li>3. Check gas valve circuit, both main valve and proof of closure switch (if so equipped).</li> <li>4. Main valve opening too slow. Adjust bleed on diaphragm valve.</li> <li>5. Shut-off cock or test cock not open.</li> <li>6. Defective main valve.</li> </ol> |
| <p>Occasional lockout for no apparent reason.</p>  | <ol style="list-style-type: none"> <li>1. Re-check microamp or D.C. voltage readings. If sufficient, check gas pressure an air damper setting. Check electrodes setting. If flame rod pilot, flame rod may have to be re-positioned.</li> <li>2. Check ignition cable and electrode porcelain for damage or breaks which could cause short.</li> <li>3. Check for loose or broken wires.</li> </ol>   |
| <p>Burner will not start even though burner has never failed before or has been running on normal cycle without failure.</p> | <ol style="list-style-type: none"> <li>1. Operating control circuit open.</li> <li>2. Starting interlock such as proven low fire switch or proof of closure switch open.</li> <li>3. Defective control or loose wiring.</li> <li>4. Limit circuit open.</li> </ol>  |
| <p>Flame Safeguard</p>   | <p>For information on Honeywell flame safeguard and relay troubleshooting, refer to Honeywell technical literature number 65-0229-1.</p>  |

# WATER GAUGE & GAUGE GLASS INSTALLATION GUIDE

20100, 20200, 20300, 20400, 20600, 20700, 20800, 21100, 21200, 22000, 22100, 22200, 23400, 23600, 24300, 24400, 24600, 24700, 24800, 25200, 25400, 25500, 25600, 20LF SERIES

Only properly trained personnel should install and maintain water gauge glass and connections. Remember to wear safety gloves and glasses during installation. Before installing, make sure all parts are free of chips and debris.

1. Apply thread sealant or tape to pipe threads. Install top gauge fitting (fitting without a drain valve) into the uppermost tapping. Wrench tighten the fitting until it is snug and the glass outlet is pointing at five o'clock (about 1/8 turn from its final downward vertical position).
2. Install the bottom gauge fitting (the fitting with a drain valve) until it is snug and the glass outlet is pointing directly upward.
3. Remove glass packing nut, friction washer (or packing gland, depending on the model), and glass packing from each gauge fitting. Slide the packing nut, then friction washer or packing gland, then and glass packing onto each end of glass.
4. Gently insert one end of the glass into the top gauge fitting. Keeping the glass inside the top fitting, gently rotate the top gauge fitting clockwise until vertically aligned with the bottom gauge fitting, then insert glass into bottom fitting until glass bottoms out on the shoulder inside the bottom fitting.
5. Carefully raise glass about 1/16" and slide lower glass packing down until the glass packing contacts the lower gauge fitting. **DO NOT** allow the glass to remain in contact with any metal!
6. Carefully slide upper glass packing up as far as possible.
7. Hand tighten both glass packing nuts, then tighten 1/2 turn more by wrench. Tighten only enough to prevent leakage. **DO NOT OVER TIGHTEN!** If any leakage should occur, tighten slightly, a quarter turn at a time, checking for leakage after each turn.

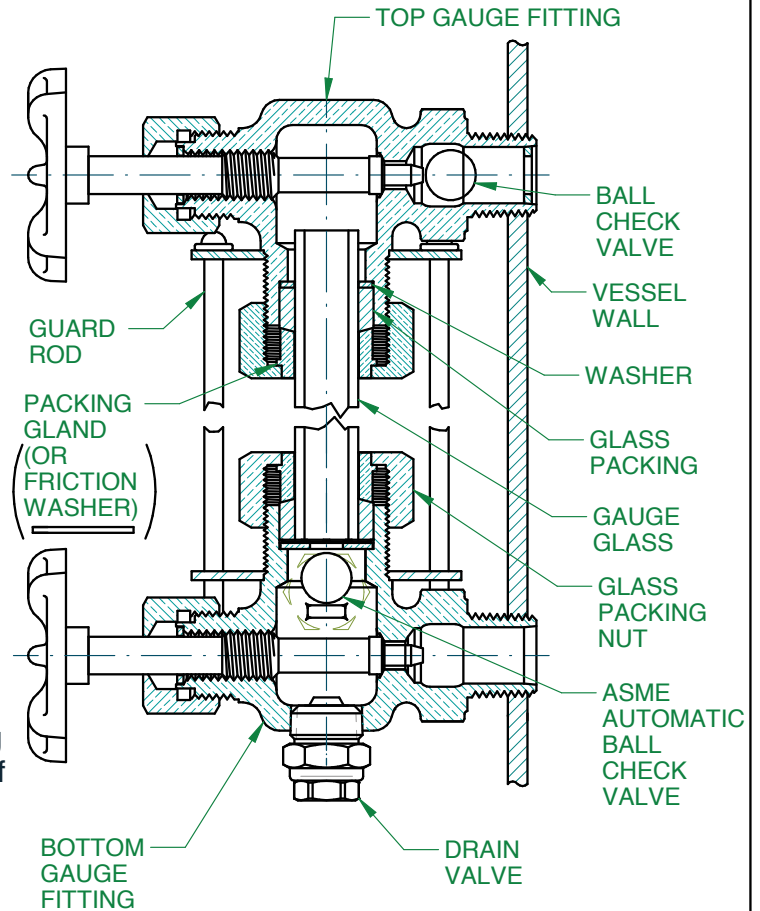

**NOTE: NOT ALL WATER GAUGES ARE EQUIPPED WITH BALL CHECK VALVES**

## WARNING!

VALVE MUST BE USED IN THE FULLY OPEN POSITION FOR PROPER OPERATION OF BALL CHECK. FAILURE TO DO SO COULD RESULT IN BODILY INJURY AND/OR PROPERTY DAMAGE.

This product contains chemicals known to the State of California to cause cancer and birth defects or other reproductive harm. (California law requires that this warning be given to the consumers in the State of California).

### U.S. SAFE DRINKING WATER ACT WARNING:

It is illegal to use products that contain lead for potable water services (Water intended for human consumption) in the United States.

## WATER GAUGE GLASS

### NOTICE:

READ ALL WARNINGS AND INSTRUCTIONS BEFORE PERFORMING INSTALLATION OR MAINTENANCE.

### WARNING!

SAFETY GLASSES AND GLOVES SHOULD BE WORN AT ALL TIMES WHEN WORKING WITH OR EXAMINING WATER GAUGE GLASS AND CONNECTIONS.

IMPROPER INSTALLATION OR MAINTENANCE OF GAUGE GLASS AND CONNECTIONS CAN CAUSE IMMEDIATE OR DELAYED BREAKAGE RESULTING IN BODILY INJURY AND/OR PROPERTY DAMAGE.

### MAINTENANCE

Examine the gauge glass regularly for any signs of clouding, scratching, erosion, or corrosion. The glass should be inspected daily until the need for replacement becomes apparent. This will help establish the routine inspection and routine replacement schedules.

### CLEANING

Use commercial non-abrasive glass cleaners to keep the glass clean. Use diluted acids such as Hydrochloric (muriatic) acid when regular cleaners do not seem to work. Do not use wire brushes or any other abrasive materials which could scratch the glass.

### INSPECTION

Examine the surface of the glass for scratches, corrosion, chips, cracks, surface flaws, or nicks. To do this, shine a very bright concentrated light at an angle of about 45 degrees. A defective glass will glisten as the light strikes imperfections. Glass which appears cloudy or roughened, will not respond to cleaning, and should be replaced.

### STORING

Keep gauge glass in original packaging until ready to install.

## WATER GAUGE GLASS

### DO's

- DO verify proper gauge has been supplied.
- DO examine gauge glass and packings carefully for damage before installation.
- DO install protective guards and utilize automatic ball checks where necessary to help prevent injury in case of glass breakage.
- DO inspect the gauge glass daily, keep maintenance records, and conduct routine replacements.
- DO protect glass from sudden changes in temperatures such as drafts, water spray, etc.

### DO NOT's

- DO NOT use the glass if it contains any chips or any other visible signs of damage.
- DO NOT reuse any tubular glass or glass packings.
- DO NOT subject gauge glass to bending or torsional stresses.
- DO NOT over tighten glass packing nuts.
- DO NOT allow glass to touch any metal parts.
- DO NOT exceed the recommended pressure of the gauge or gauge glass.
- DO NOT clean the gauge or gauge glass while pressurized or in operation.



Manufactured by Conbraco Industries, Inc.  
1418 S. PEARL ST.  
PAGELAND, SC 29728  
TELEPHONE (704) 841-6000  
[www.apollovalves.com](http://www.apollovalves.com)

## Easy Topog-E® Boiler Installation Instructions

1. Remove old gasket and thoroughly clean the surface on boiler and on cover plate. Sometimes it is necessary to buff each surface.
2. Place Topog-E® Gasket on handhole cover plate. Be sure the gasket is pushed down tight on the plate. Do not use any grease, lubricant, or adhesive.

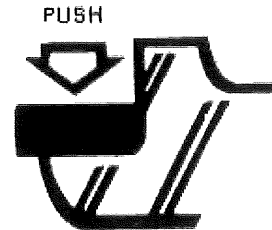

3. After cover plate is in boiler and gasket is in place, make one last cleaning swipe of the mating surface in the boiler. Use a rag wrapped around your finger.

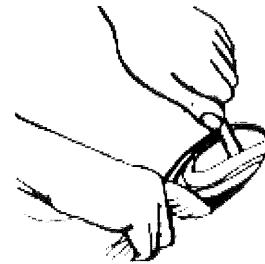

4. Set crab, then center plate in opening and tighten nut enough to give a snug fit. Then, snug up with 1/4 turn of wrench.

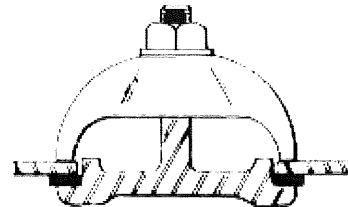

### SPECIAL NOTES:

- If gasket leaks while pressure is being built up, tighten only enough to stop leakage. Never over-compress a gasket.
- Gaskets on the bottom of a boiler shell are usually hard to install without leaking because particles of scale or sand tend to run down onto the mating surface between the time the surface is cleaned and the handhole cover plate is put into place ready

to be tightened. When this happens, drain the boiler again and start over, or expect to replace the gasket in a very short time.

- As pressure builds up in the boiler the bolt and crab will loosen. It takes some time for the gasket to reach its ultimate compression, so the operator should watch this for several days and keep the bolt tight until it no longer loosens. This is especially true if the boiler is operated intermittently; i.e., shut off at night to allow pressure to drop. In this case, vacuum pressure in the boiler would suck the cover plate in and allow the water to leak out of the boiler.
- Re-using gaskets after they have been in service is not recommended!

**Topog-E® Bolt Gaskets (when required) should be used with Topog-E® Handhole Gaskets.**

Topog-E® Gaskets are sold for use in steam, water, air, and other selected applications only. Recommendations for use of Topog-E Gaskets are based on tests believed to be reliable and on actual customer experience. Since their installation and use is beyond our control we cannot guarantee the results, whether or not such use is in accordance with directions. We disclaim any responsibility.

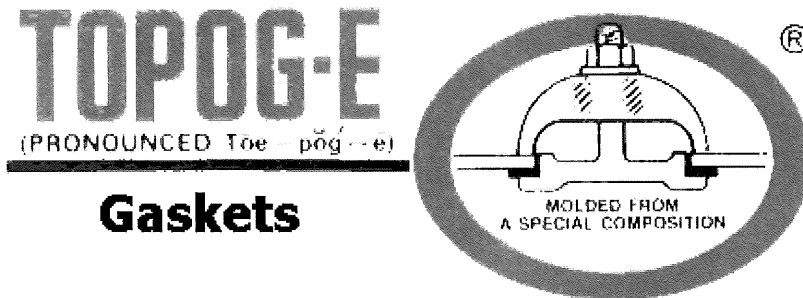

1224 North Utica  
Tulsa, OK 74110-4682  
1-800-587-7123  
918-587-6649  
Fax: 918-587-6961  
[topogesales@topog-e.com](mailto:topogesales@topog-e.com)

# KUNKLE PRESSURE RELIEF VALVES

## Installation and Operating Instructions

---

### Pre-Installation Handling

This pressure relief valve is designed to protect equipment from overpressure. The valve should be handled with care, not subjected to heavy shock loads, and protected to prevent contamination from getting inside. It should be installed correctly per A.S.M.E. Boiler & Pressure Vessel Code requirements. Failure to do so could result in property damage or serious injury to personnel. When hoisting the valve into position for installation, care should be exercised so that lifting straps do not contact the valve lift lever.

### Installation

Always wear proper safety equipment, including safety glasses and ear protection.

1. Mount the valve in a vertical position so that the valve body is self-draining. If a body drain port is provided, make sure it is open when required by the ASME code. Do not plug any bonnet vent openings. The inlet piping should be as short as possible, with no elbows, and equal to or greater than the size of the pressure relief valve inlet connection. This will help to limit the inlet pressure drop to 3% or less when the valve is relieving.
2. When discharge piping is connected to valve outlet, make sure it is self draining if a body drain port is not used. The valve should not be connected to any discharge pipe that contains pressure before the valve opens or to any pipe where the pressure build-up is greater than 10% of the set pressure when the valve is open and relieving.

Discharge piping, other than a short tailpipe, must be supported. For steam service, a drip pan elbow or flexible connection between the valve and the pipe should be used to prevent excessive pipe stress, due to thermal expansion, from being imposed on the valve body.

3. For threaded valves, to prevent sealing compound from entering and damaging the valve, apply a small amount of pipe thread sealing compound to external threads only. Do not put any sealing compound on the first thread or on any internal threads. To do so may cause the sealing compound to enter the valve and cause seat leakage.

Do not use the valve body or bonnet for installing the valve in threaded connections. Use the wrench flats provided to tighten the valve to the connecting pipe, and do not overtighten. To do so may cause valve leakage.

4. For flanged valves, use new gaskets and tighten the mounting studs evenly.

### Operation

1. Maintain a system operating pressure at least 5 psig or 10% below the set pressure of the valve, whichever is greater. Operating too close to the valve set pressure will cause seat leakage and will shorten the time between valve maintenance.
2. Do not use the safety valve as a control valve to regulate system operating pressure. Excessive operation will cause the seat to leak and will require more frequent valve maintenance.
3. ASME Section I and VIII valves equipped with lift levers are designed to be operated only when the system pressure is 75% of set pressure or greater. ASME Section IV valves may be operated at any set pressure. When hand operating the valve, hold it open long enough to purge any foreign matter from the seat area. If a cable or wire is attached to the lift lever for remote actuation, make sure the direction of pull is the same as it would be if the lever were pulled directly by hand.

### Maintenance

Maintenance should be performed on a regular basis. An initial inspection interval of 12 months is recommended. Depending on the service conditions and the condition of the valve, the inspection interval may be decreased or increased. Use only Kunkle parts for repair. Depending on the local jurisdictional requirements where the valve is installed, repairs may have to be made by a repair facility holding a VR stamp.

### WARNING!

Removal of the seal wires or any attempt to adjust, repair or modify this product by non-qualified or non-authorized persons voids the product guarantee and may cause serious damage to equipment, personal injury, and death. Kunkle Valve is not liable for any damage resulting from misuse or misapplication of its products.



# McDonnell & Miller

Installation & Maintenance  
Instructions  
MM-217(I)

## Series 150S and 157S



(Snap Switch, All Models except 157S-RB-P)

## Low Water Cut-Off/Pump Controllers For Steam Boilers and Other Level Control Applications

### Typical Applications:

- Primary or secondary pump controller/  
low water fuel cut-off  
for steam boilers
- Motorized valve controller
- Low water cut-off
- High water cut-off
- Alarm actuator

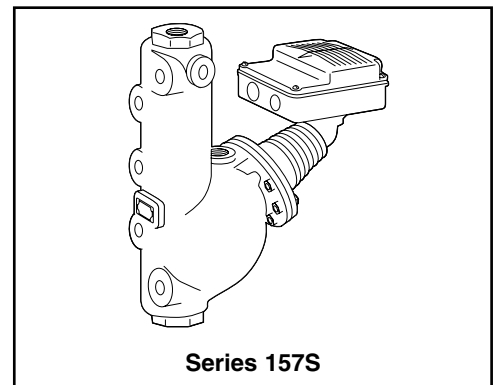
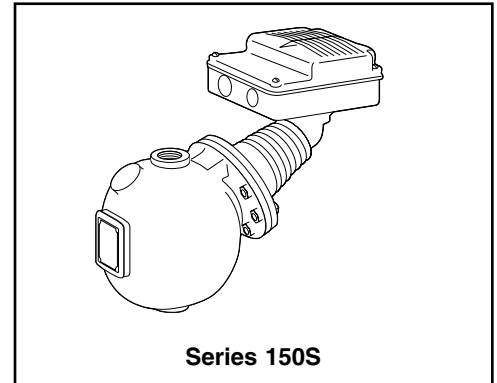

## WARNING

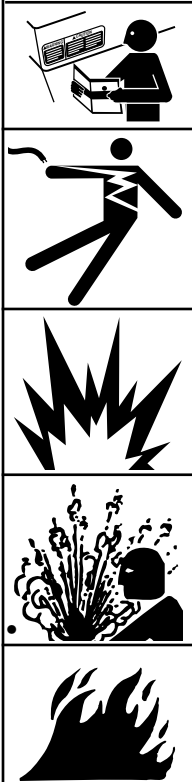

- Before using this product read and understand instructions.
  - Save these instructions for future reference.
  - All work must be performed by qualified personnel trained in the proper application, installation, and maintenance of plumbing, steam, and electrical equipment and/or systems in accordance with all applicable codes and ordinances.
  - To prevent serious burns, the boiler must be cooled to 80°F (27°C) and the pressure must be 0 psi (0 bar) before servicing.
  - To prevent electrical shock, turn off the electrical power before making electrical connections.
  - This low water cut-off must be installed in series with all other limit and operating controls installed on the boiler. After installation, check for proper operation of all of the limit and operating controls, before leaving the site.
  - We recommend that secondary (redundant) Low Water Cut-Off controls be installed on all steam boilers with heat input greater than 400,000 BTU/hour or operating above 15 psi of steam pressure. At least two controls should be connected in series with the burner control circuit to provide safety redundancy protection should the boiler experience a low water condition. Moreover, at each annual outage, the low water cut-offs should be dismantled, inspected, cleaned, and checked for proper calibration and performance.
  - To prevent serious personal injury from steam blow down, connect a drain pipe to the control opening to avoid exposure to steam discharge.
  - To prevent a fire, do not use this low water cut-off to switch currents over 7.4A, 1/3 Hp at 120 VAC or 3.7A, 1/3 Hp at 240 VAC, unless a starter or relay is used in conjunction with it.
- Failure to follow this warning could cause property damage, personal injury or death.

# OPERATION

Maximum Pressure: 150 psi (10.5 kg/cm<sup>2</sup>)

## Electrical Ratings

| Voltage | Pump/Circuit Rating (Amperes) |              | Pilot Duty     |
|---------|-------------------------------|--------------|----------------|
|         | Full Load                     | Locked Rotor |                |
| 120 VAC | 7.4                           | 44.4         | 345 VA at      |
| 240 VAC | 3.7                           | 22.2         | 120 or 240 VAC |

| Alarm Circuit Rating |      |
|----------------------|------|
| Voltage              | Amps |
| 120 VAC              | 1    |
| 240 VAC              | 1/2  |

| Motor Horsepower |     |
|------------------|-----|
| Voltage          | Hp  |
| 120 VAC          | 1/3 |
| 240 VAC          | 1/3 |

Enclosure rating: NEMA 1 General Purpose

## Settings and Differential Pressures

Values are  $\pm 1/8"$  (3.2mm).

### Series 150S, 157S

| Pressure                           | Setting    | Approximate Distance Above Cast Line In. (mm) | Differential In. (mm) |
|------------------------------------|------------|---|-----------------------|
| 0 psi (0 kg/cm <sup>2</sup> )      | Pump Off   | 15/16 (24)                                    | 5/16 (8)              |
|                                    | Pump On    | 5/8 (16)                                      |                       |
|                                    | Burner On  | 5/8 (16)                                      | 3/8 (16)              |
|                                    | Burner Off | 1/4 (6.4)                                     |                       |
| 150 psi (10.5 kg/cm <sup>2</sup> ) | Pump Off   | 1 3/8 (41)                                    | 3/4 (19)              |
|                                    | Pump On    | 5/8 (16)                                      |                       |
|                                    | Burner On  | 7/8 (22)                                      | 7/8 (22)              |
|                                    | Burner Off | 0 (0)   |                       |

### 150 psi (10.5 kg/cm<sup>2</sup>) Levels

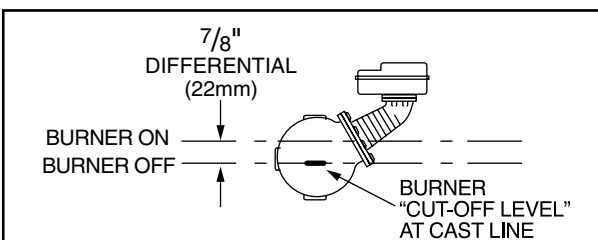
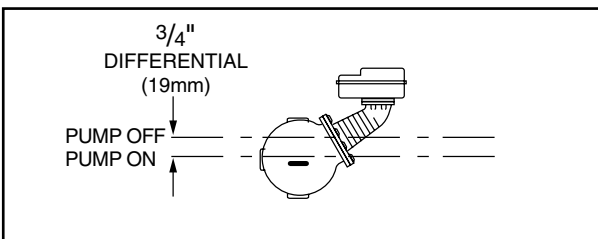
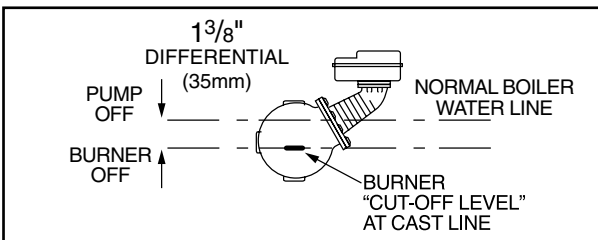

### Model 150S-MD, and 157S-MD

| Pressure                           | Setting    | Approximate Distance Above Cast Line In. (mm) | Differential In. (mm) |
|------------------------------------|------------|---|-----------------------|
| 0 psi (0 kg/cm <sup>2</sup> )      | Pump Off   | 15/16 (24)                                    | 3/8 (16)              |
|                                    | Pump On    | 9/16 (14)                                     |                       |
|                                    | Burner Off | 0 (0)   | N/A                   |
| 150 psi (10.5 kg/cm <sup>2</sup> ) | Pump Off   | 1 7/16 (37)                                   | 3/4 (19)              |
|                                    | Pump On    | 11/16 (17)                                    |                       |
|                                    | Burner Off | - 3/8 (-16)                                   | N/A                   |

### 150 psi (10.5 kg/cm<sup>2</sup>) Levels

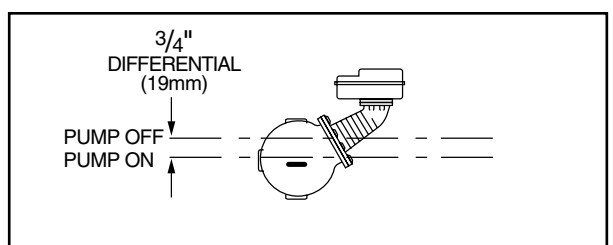
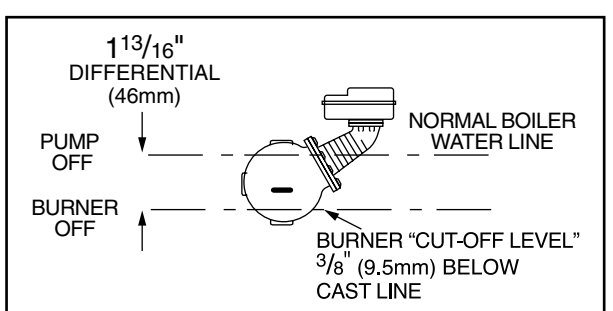

## Settings and Differential Pressures (continued)

Values are  $\pm 1/8$ " (3.2mm).

### Model 158S

| Pressure                                | Setting                | Approximate Distance Above Cast Line In. (mm) | Differential In. (mm) |
|---|------------------------|---|-----------------------|
| <b>0 psi (0 kg/cm<sup>2</sup>)</b>      | Motorized Valve Closed | 15/16 (24)                                    | 5/16 (8)              |
|   | Motorized Valve Open   | 5/8 (16)                                      |                       |
|   | Burner On              | 5/8 (16)                                      | 3/8 (16)              |
|   | Burner Off             | 1/4 (6.4)                                     |                       |
| <b>150 psi (10.5 kg/cm<sup>2</sup>)</b> | Motorized Valve Closed | 1 3/8 (41)                                    | 3/4 (19)              |
|   | Motorized Valve Open   | 5/8 (16)                                      |                       |
|   | Burner On              | 7/8 (22)                                      | 7/8 (22)              |
|   | Burner Off             | 0 (0)   |                       |

### 150 psi (10.5 kg/cm<sup>2</sup>) Levels

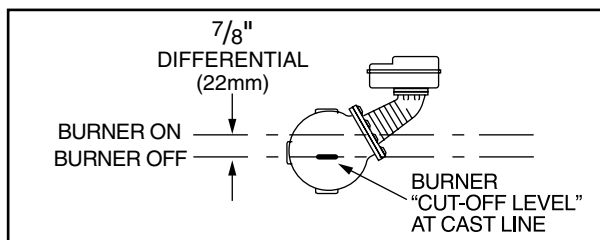
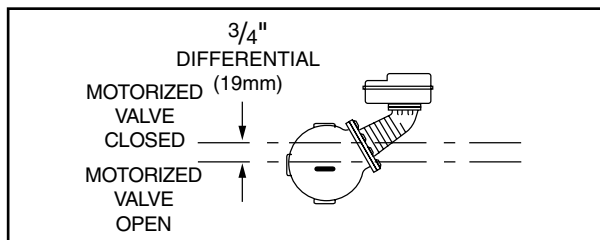
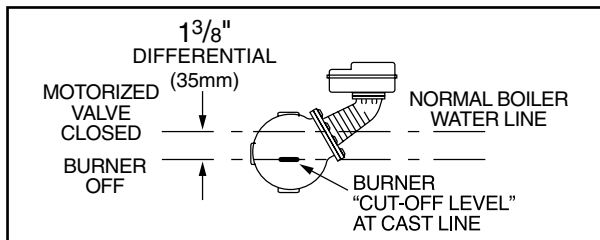

NOTE: Due to the slower operation of some motorized valves, complete valve opening or closing will occur at slightly different levels than indicated above.

### Model 158S-MD

| Pressure                                | Setting    | Approximate Distance Above Cast Line In. (mm) | Differential In. (mm) |
|---|------------|---|-----------------------|
| <b>0 psi (0 kg/cm<sup>2</sup>)</b>      | Pump Off   | 15/16 (24)                                    | 3/8 (16)              |
|   | Pump On    | 9/16 (14)                                     |                       |
|   | Burner Off | 0 (0)   | N/A                   |
| <b>150 psi (10.5 kg/cm<sup>2</sup>)</b> | Pump Off   | 17/16 (37)                                    | 3/4 (19)              |
|   | Pump On    | 11/16 (17)                                    |                       |
|   | Burner Off | - 3/8 (-16)                                   | N/A                   |

### 150 psi (10.5 kg/cm<sup>2</sup>) Levels

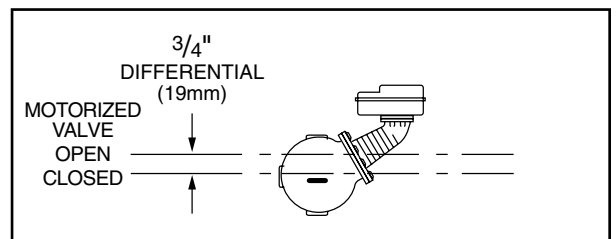
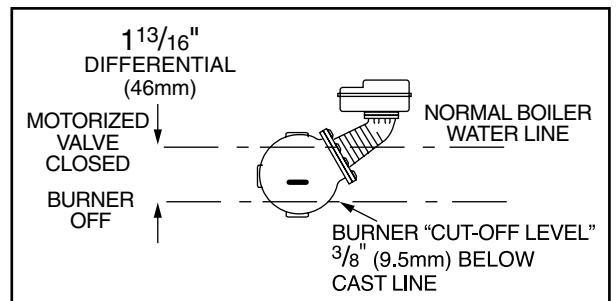

NOTE: Due to the slower operation of some motorized valves, complete valve opening or closing will occur at slightly different levels than indicated above.

## Settings and Differential Pressures (continued)

Values are  $\pm 1/8"$  (3.2mm).

### Model 159S

| Pressure  | Setting     | Approximate Distance Above Cast Line In. (mm) | Differential In. (mm) |
|---|-------------|---|-----------------------|
| <b>0 psi</b><br><b>(0 kg/cm<sup>2</sup>)</b>      | Pump #1 Off | 15/16 (24)                                    | 5/16 (8)              |
|   | Pump #1 On  | 5/8 (16)                                      |                       |
|   | Pump #2 Off | 5/8 (16)                                      | 3/8 (16)              |
|   | Pump #2 On  | 1/4 (6.4)                                     |                       |
| <b>150 psi</b><br><b>(10.5 kg/cm<sup>2</sup>)</b> | Pump #1 Off | 1 3/8 (41)                                    | 3/4 (19)              |
|   | Pump #1 On  | 5/8 (16)                                      |                       |
|   | Pump #2 Off | 7/8 (22)                                      | 7/8 (22)              |
|   | Pump #2 On  | 0 (0)   |                       |

### 150 psi (10.5 kg/cm<sup>2</sup>) Levels

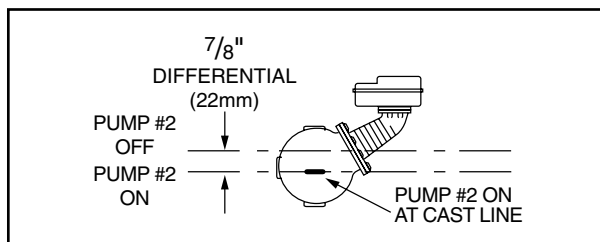
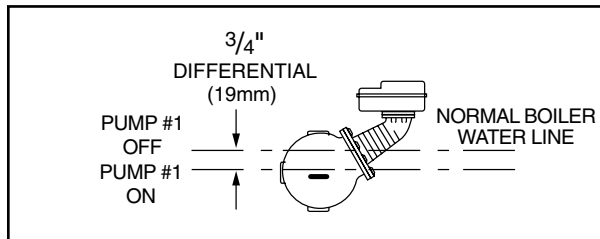
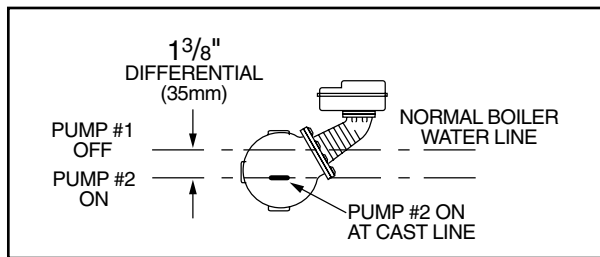

# INSTALLATION

## TOOLS NEEDED:

Two (2) pipe wrenches, one (1) flathead screw driver, and pipe sealing compound.

**IMPORTANT:** Follow the boiler manufacturer's instructions along with all applicable codes and ordinances for piping, blow down valve and water gauge glass requirements.

## STEP 1 - Determine the Elevation at Which the Low Water Cut-Off/Pump Controller Must be Installed

If the control will be the **primary low water fuel cut-off**, size the steam (top) and water (bottom) equalizing pipe lengths so that the horizontal cast line on the body is **1 3/8" (35mm) below** the boiler's **normal water level**, but not lower than the **lowest, safe permissible water level**, as determined by the boiler manufacturer.

OR

If the control will be the **secondary low water fuel cut-off**, size the steam (top) and water (bottom) equalizing pipe lengths so that the horizontal cast line on the body is **at or above**, the **lowest, safe permissible water level**, as determined by the boiler manufacturer.

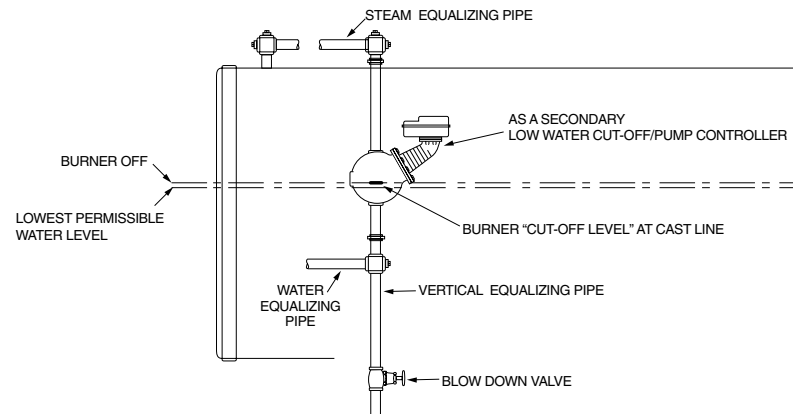
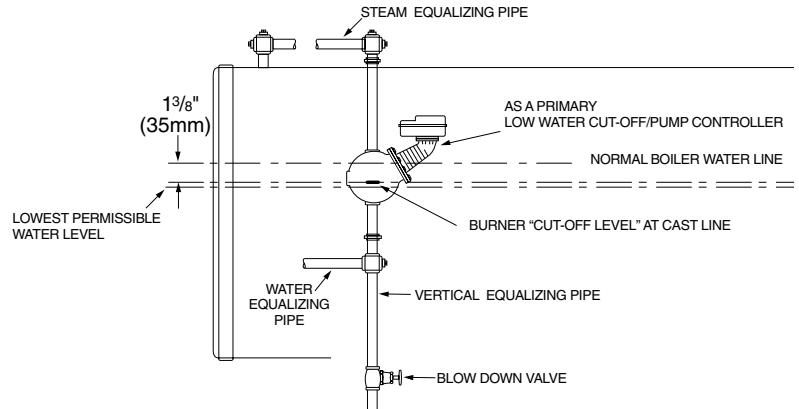

## STEP 2 - Installing the Low Water Cut-Off

- a. Using a pipe wrench, unscrew the plastic float blocking plug (A) from the low water cut-off body (B).

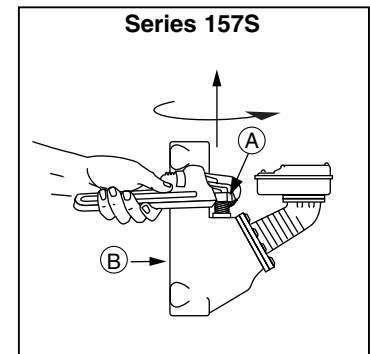
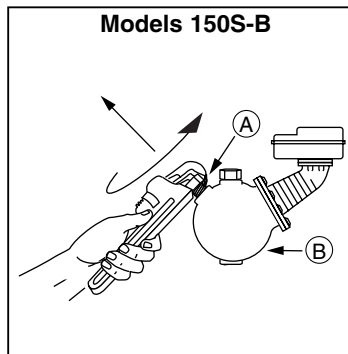
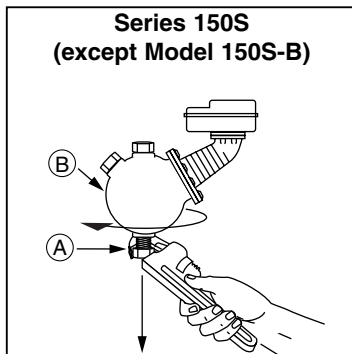

**b. For Model 150S-B and Series 157S**

(For all other models, proceed to Step 3).

Screw the 3/4" NPT steel plug (C) (provided) in tapping (A).

**CAUTION**

The plug must be reinstalled before control is shipped installed on the boiler, and removed when boiler is installed after shipment. Failure to follow this caution may damage float and operating mechanism.

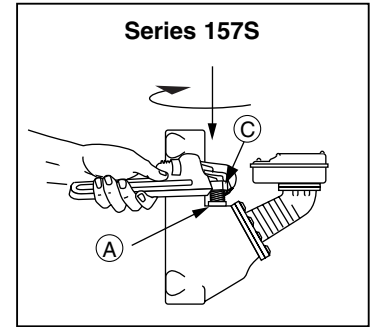
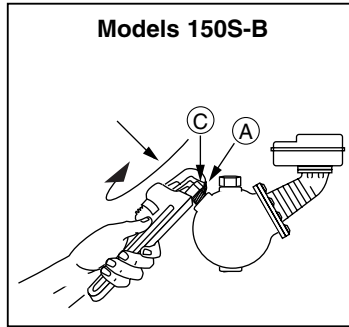

**c. Mount and pipe the low water cut-off (D) on a vertical equalizing pipe (E) at the required elevation level, as determined in Step 1.**

Install a full ported blow down valve (G) directly below the lower cross of the water equalizing pipe (F).

**Note:** 1" NPT tappings are provided, with the exception of some 157 and 157S models which are 1 1/4" NPT.

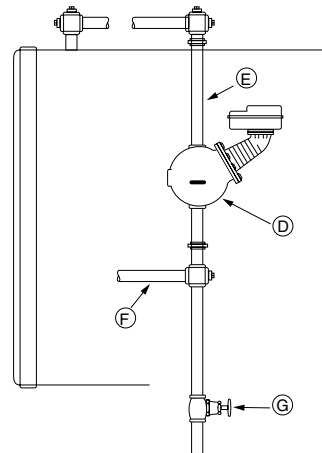

**STEP 3 - Installing a Water Gauge Glass (Required on all steam boilers)**

**a. Install a water column (H) (not included with product) for all models except Series 157S (with integral water column).**

**b. Install a water gauge glass (J).**  
**Note:** Gauge glass and tri-cocks not included with product.

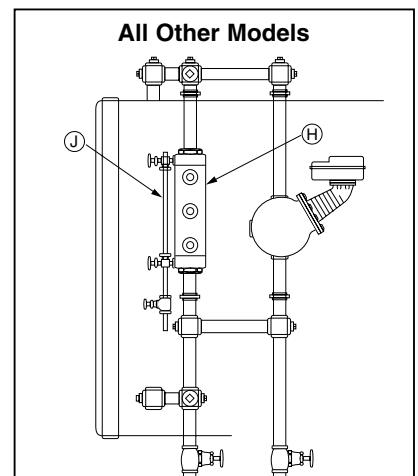
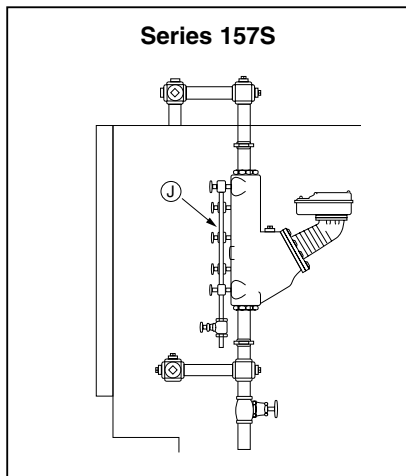

## STEP 4 - Electrical Wiring

### WARNING



- To prevent a fire, do not use this product to switch currents over 7.4A, 1/3 Hp at 120 VAC or 3.7A, 1/3 Hp at 240 VAC, unless a starter or relay is used in conjunction with it.
- To prevent electrical shock, turn off the electrical power before making electrical connections.
- This low water cut-off must be installed in series with all other limit and operating controls installed on the boiler. After installation, check for proper operation of all of the limit and operating controls, before leaving the site.



- Modification of the switch assembly before or after installation could cause damage to the boiler and/or boiler system.
- Failure to follow this warning could cause electrical shock, an explosion and/or a fire, which could result in property damage, personal injury or death.

### Switch Operation

#### For all Models except 158S and 159S

Boiler feed pump off,  
burner on, alarm off.

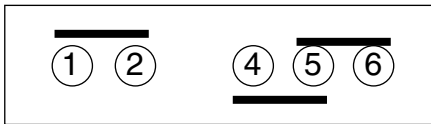

Boiler feed pump on,  
burner on, alarm off.

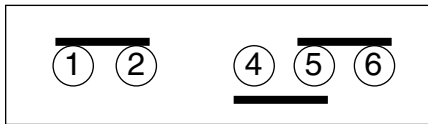

Boiler feed pump on,  
burner off, alarm on.

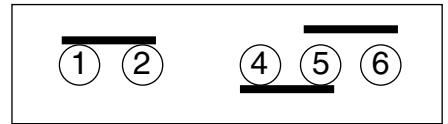

#### For Model 158S

Motorized valve closed,  
burner on, alarm off.

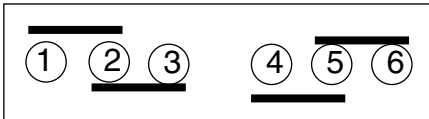

Motorized valve open,  
burner on, alarm off.

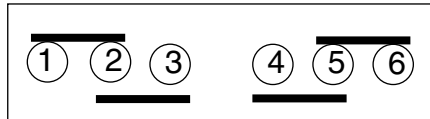

Motorized valve open,  
burner off, alarm on.

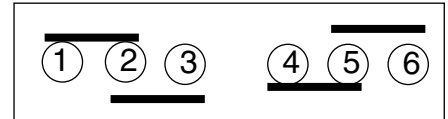

#### For Model 159S

Pump #1 off,  
pump #2 off.

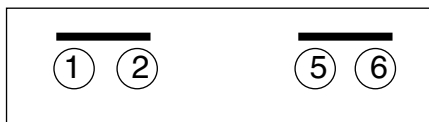

Pump #1 on,  
pump #2 off.



Pump #1 on,  
pump #2 on.

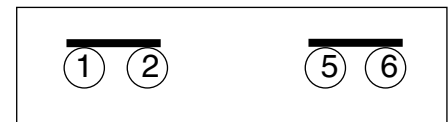

- Using a flathead screwdriver, remove the junction box cover (K).

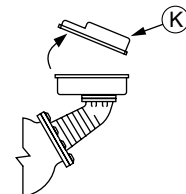

b. Following the appropriate wiring diagram, (refer to page 9) based on your application requirements, and using BX armored cable or Thinwall electrical metal tubing connector fittings, make electrical connections to the junction box (L).

**IMPORTANT:** There must be a minimum space of 1/2" (13mm) between connector fittings and electrical live metal parts.

**Snap Switches (Series 150S and 157S)**

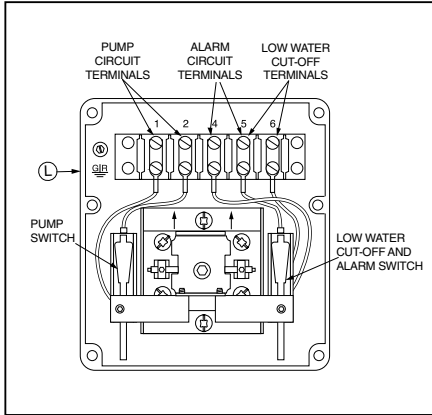

**Automatic Reset  
(All models except 158S and 159S)**

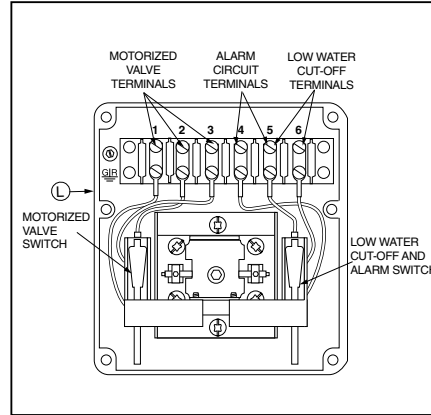

**Automatic Reset  
Model 158S**

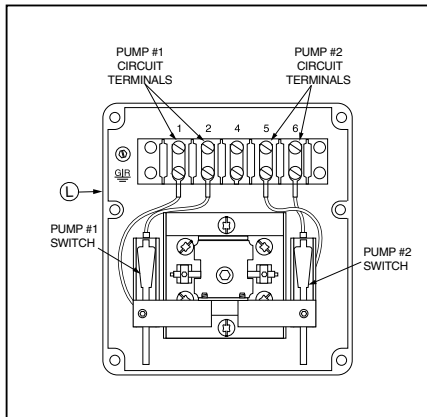

**Automatic Reset  
Model 159S**

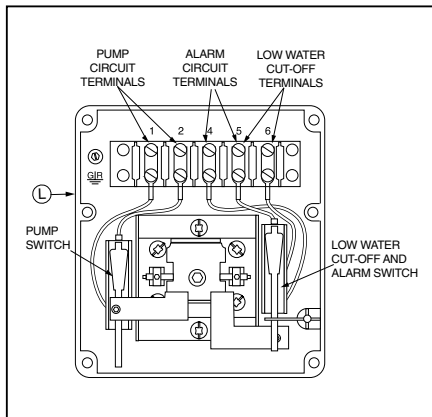

**Manual Reset  
(All models except 158S)**

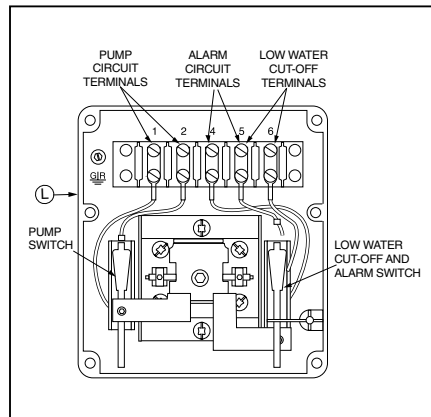

**Manual Reset  
Model 158S-M**

# WIRING DIAGRAMS

For Motorized Valves, refer to the valve manufacturer's wiring instructions.

## Low Water Cut-Off Only

1. Main Line Switch - For burner circuits within the switch's electrical rating.
2. Pilot Switch - To holding coil of a starter when the burner circuit exceeds the switch's electrical rating.

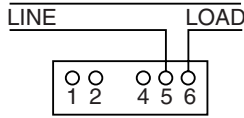

OR

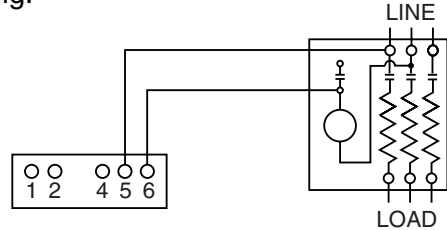

## Pump Control Only

1. Install a starter or relay in pump control circuit, as shown, to prevent damage to snap switch and help insure proper switch/control operation. Failure to do so may shorten the life of the switch when actual amperage exceeds switch rating.

**NOTE:** For Model 159S, use terminals 5 and 6 from starter or relay for pump # 2.

2. Connect wires from holding coil of pump starter or relay to terminals 1 and 2 as shown.

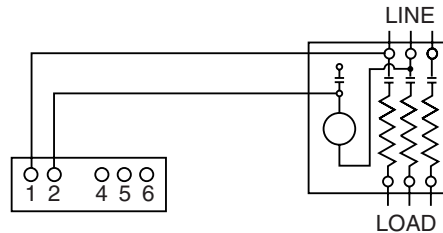

**NOTE:** To help insure most effective operation, balance boiler feed pump(s) to deliver required water feeder rate to match boiler steaming requirements.

## Alarm Circuit Only

1. Low Water Alarm

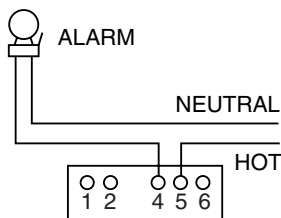

2. High Water Alarm

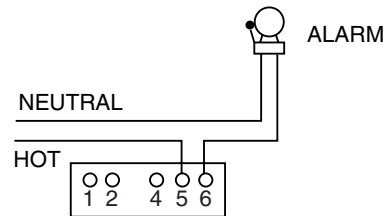

OR

## Combination Pump Control, Low Water Cut-Off and Alarm

1. Main Line Switch - For burner circuits within the switch's electrical rating.
2. Pilot Switch - To holding coil of a starter when the burner circuit exceeds the switch's electrical rating.

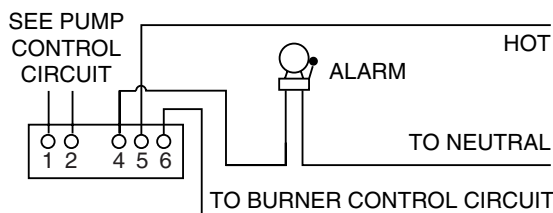

OR

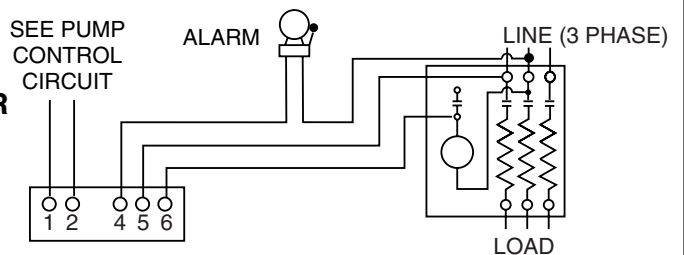

6. Re-attach the junction box cover (K).

**Note:**  
Cover must be installed correctly as shown

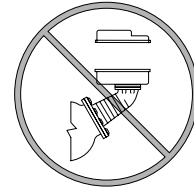
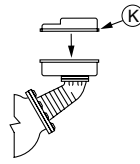

## STEP 5 - Testing

This control is factory calibrated for specific applications. The following testing procedure is only meant to serve as a verification of proper operating sequence. Dimensions provided are typical for a boiler not being fired and/or not at pressure. Actual operating ranges are shown on page 2 in the "Operation" section.

**IMPORTANT:** Follow the boiler manufacturer's start-up and operating instructions along with all applicable codes and ordinances. **Note:** Water levels stated below are only for 150 psi (10.5 kg/cm<sup>2</sup>) operation.

- a. Turn on the electric power to the boiler. With the boiler empty the pump should go on and the burner must remain off.

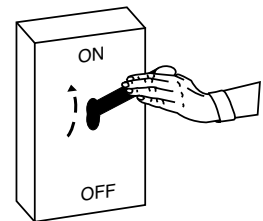

**WARNING**



If the burner comes on, immediately turn the boiler off and make the necessary corrections.

Failure to follow this warning could cause an explosion or fire and result in property damage, personal injury or death.

- b. The boiler should begin to fill with water. Watch the gauge glass (J) until the water level reaches approximately  $\frac{7}{8}$ " (22mm) above the horizontal cast line (M) on the low water cut-off.

**IMPORTANT:** If water does not start filling the boiler, immediately turn off the the boiler and make the necessary corrections.

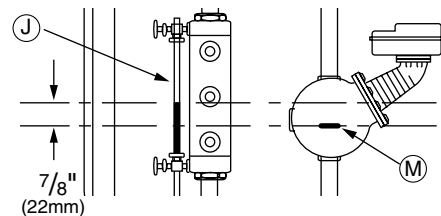

c. **For automatic reset models only.** When the water level reaches approximately  $\frac{7}{8}$ " (22mm) above the horizontal cast line (lower for MD models) the burner should come on (pump #2 should shut off with Model 159S).

OR

**For manual reset models only.** When the water level reaches approximately  $\frac{7}{8}$ " (22mm) above the horizontal cast line press the reset button (N). The burner should then come on.

#### Snap Switch Models

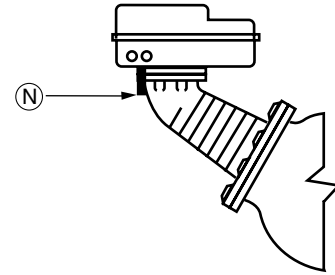

d. Continue watching the gauge glass (J) to see that the water continues to rise to approximately  $1\frac{3}{8}$ " (35mm) ( $1\frac{7}{16}$ " (37mm) for MD models) above the horizontal cast line (M). The pump should shut off (the motorized valve should close with Models 158 and 158S, or with Models 159 and 159S, pump #1 should shut off).

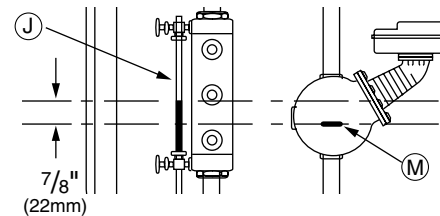

### CAUTION



To prevent serious personal injury from steam pipe blow down, connect a pipe to avoid exposure to steam discharge.

Failure to follow this caution could cause personal injury.

e. Blow down the control when the water in the boiler is at its normal level and the burner is on. Follow Blow Down Procedure found in Maintenance Section on the last page of these instructions.

**INSTALLATION COMPLETE**

# MAINTENANCE

## SCHEDULE:

Blow down control as follows when boiler is in operation.

- Daily if operating pressure is above 15 psi.
- Weekly if operating pressure is below 15 psi.

### NOTE

More frequent blow-down may be necessary due to dirty boiler water and/or local codes.

- **Remove head assembly and inspect water side components annually.** Replace head assembly if any of the internal components are worn, corroded or damaged or if control no longer operates properly.
- **Inspect the float chamber and equalizing piping annually.** Remove all sediment and debris.

### NOTE

The control may need to be inspected and cleaned more frequently on systems where there is the potential of excessive scale or sludge build-up. This includes systems:

- With high raw water make-up
- With no condensate return
- With untreated boiler water
- Where significant changes have been made to the boiler-water chemical treatment process
- With oil in the boiler water

Replace head mechanism every 5 years.

More frequent replacement may be required when severe conditions exist.

Replacement parts are available from your local authorized McDonnell & Miller Distributor.

The use of parts or components other than those manufactured by McDonnell & Miller will void all warranties and may affect the units compliance with listings or regulating agencies.

# BLOW DOWN PROCEDURE:

## CAUTION



To prevent serious personal injury from steam pipe blow down, connect a drain pipe to the control opening to avoid exposure to steam discharge.

Failure to follow this caution could cause personal injury.

When blowing down a control at pressure, the blow down valves should be opened slowly. The piping needs to be warmed up and stagnant water in the drain piping needs to be pushed out. Suddenly opening a blow down valve causes steam to condense, which can create water hammer.

Damage to components can occur when water hammer occurs due to improper blow down piping. For these reasons, McDonnell & Miller recommends a dual valve blow-down system for each control.

Blow down the control when the water in the boiler is at its normal level and the burner is on.

**NOTE:** Refer to page 2 for switch operating points.

- Open upper valve (#1)
- Slowly open the lower valve (#2)
- Water in the sight glass should lower.
- As the water in the sight glass lowers, the pump should turn on.
- As the water continues to lower in the sight glass, the burner should turn off.
- Slowly close the lower valve (#2).
- Close the upper valve (#1)
- The water level in the sight glass should rise, first turning on the burner and then turning off the pump.

**NOTE:** On manual reset models, the reset button will need to be pressed after the water level has been restored before the burner will operate.

### NOTE

If this sequence of operation does not occur as described, immediately close all the valves, turn off the boiler and correct the problem. Inspection/cleaning of the float mechanism may be required to determine why the control was not working properly. Retest the control after the problem has been identified and corrected.

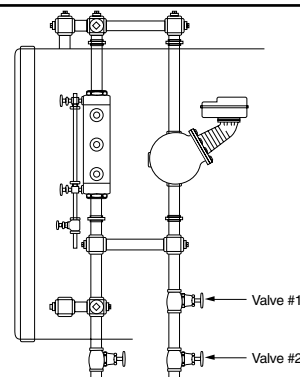

## Warrick® Series 26M Controls Installation and Operation Bulletin

This bulletin should be used by experienced personnel as a guide to the installation of series 26M controls. Selection or installation of equipment should always be accompanied by competent technical assistance. We encourage you to contact Gems Sensors or its local representative if further information is required.

### Specifications

**Control Design:** Solid State components enclosed in clear lexan plug-in style housing. Housing carries no NEMA ratings.

**Contact Design:** SPDT (1 form C): One normally open (N.O.) and one normally closed (N.C.) powered contacts.

**Contact Ratings:** 10 A @ 120,240 VAC resistive (120°F), 1A @ 120, 240 VAC resistive (150°F), 1/3 H.P. @ 120, 240 VAC (120°F)

**Contact Life:** Mechanical- 5 million operations Electrical- 100,000 operations minimum at rated load.

**Supply Voltage:** 120, 240 or 24 VAC models: +10% -15% 50/60 Hz. 208/240 model: 187 Vmin to 255 Vmax. VAC 50/60Hz

**Supply Current:** Relay energized at 4.4 VA

**Secondary Circuit:** 12 VAC RMS Voltage on probes. 1.5 milli-amp Current.

**Sensitivity:** Models operate from 4.7K to 100K maximum specific resistance.

**Temperature:** -40 TO 150°F ambient

**Terminals:** All connections #6-32 screw type terminals with pressure clamps.

**Time Delays:** Standard – LLCO probe, 3 seconds standard for lowering level.

**Listings:** U.L. limit control recognition (353). 240 and 208 volt units are not U.L. limit control recognized.

### Installation

1. Install octal socket in appropriate enclosure using two #6 or #8 metal screws.

1A. Install rail mount socket on appropriate rail (DIN mount) in appropriate enclosure if applicable.

2. Wire control per wiring diagram, following N.E.C. and local codes

3. Install control module in socket.

### Sensitivities vs Maximum Probe Wire Distance\*

| SENSITIVITY CHARACTER | SENSITIVITY (KOHMS) | DISTANCE (FT) |
|-----------------------|---------------------|---------------|
| A                     | 4.7                 | 900           |
| B                     | 10                  | 600           |
| C                     | 26                  | 250           |
| D                     | 50                  | 100           |
| E                     | 100                 | 50            |

\* Based on type MTW or THHN wire, #14 or #16 Awg

### Dimensional Diagram

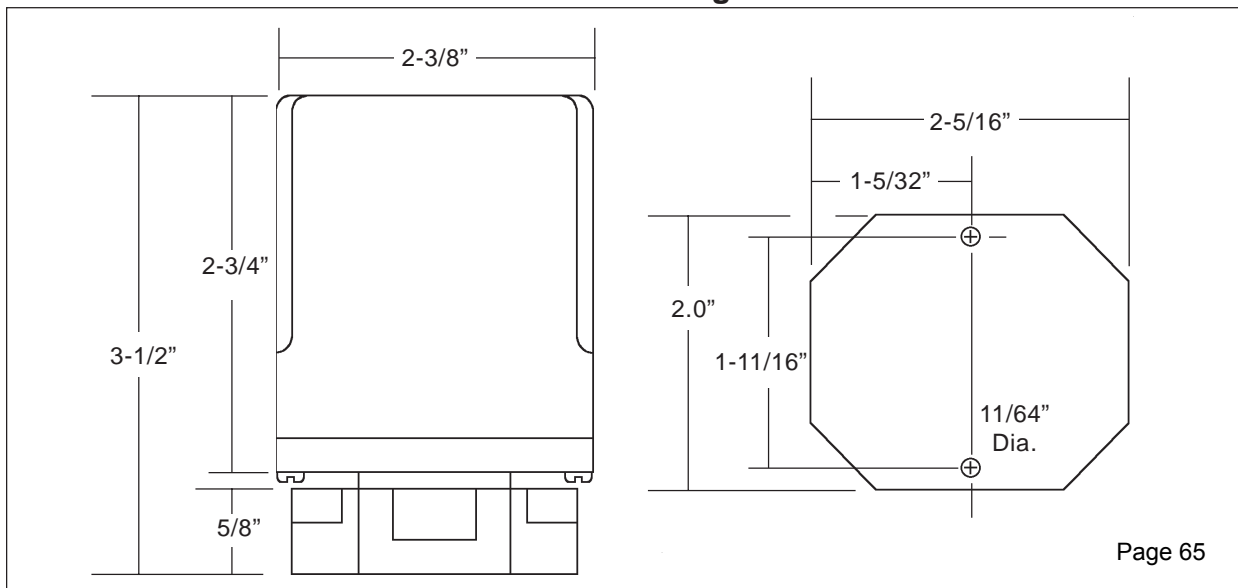

## Wiring Diagram

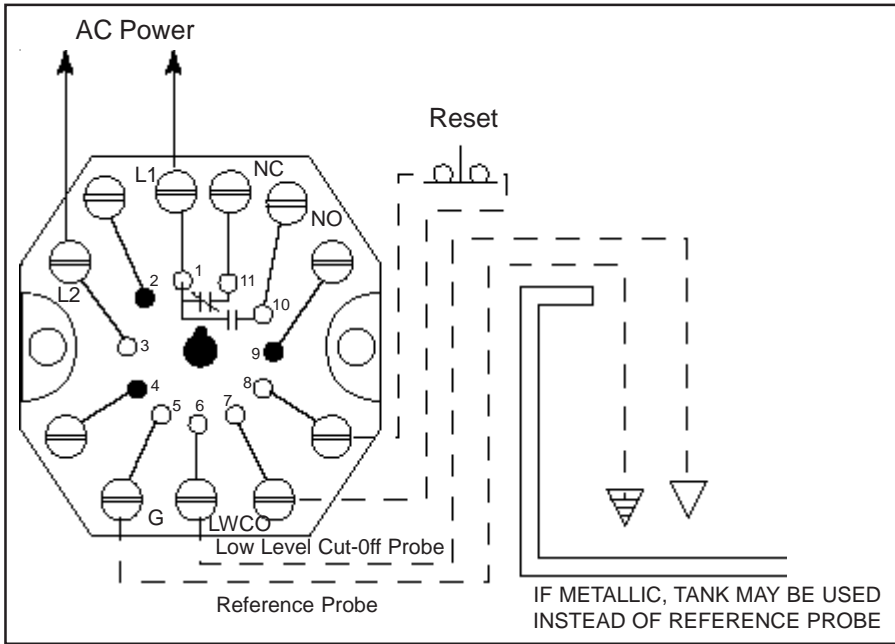

### Options:

**Automatic Reset:** (Reset terminals not used): When the liquid rises to the electrode on terminal 6, the control energizes, changing state of the load contacts. (LED will be lit) The control remains energized until the liquid level recedes below electrode on terminal 6. The control then de-energizes, (LED will not be lit) returning load contacts to original state. Unless otherwise specified, there is a three second time delay on decreasing level. Liquid must be below probe on terminal 6 for a full three seconds before control de-energizes.

**Manual Reset :** (Normally closed pushbutton installed across terminals #7 and #8): When the liquid rises to the electrode on terminal 6, the control will remain de-energized until the pushbutton is depressed. The control will then energize, (LED will be lit) changing the state of the contacts. The control remains energized until

the liquid level recedes below electrode on terminal 6. The control then de-energizes, (LED will not be lit) returning load contacts to their original state. Unless otherwise specified, there is a three second time delay on decreasing level. Liquid must be below probe on terminal 6 for full three seconds before control de-energizes.

**Manual Reset with Optional Power Outage Feature:** (Normally closed pushbutton across reset terminals) Control will ignore power loss to control. With liquid above electrode on terminal 6, a power outage will cause the control to de-energize, but will automatically energize upon return of power. However, loss of liquid will cause control to de-energize and remain so until liquid again rises to electrode and pushbutton is depressed.

**Dirty Electrode Detection:** The LED will flash every half-second once the probe resistance reaches a value greater than the nominal control sensitivity rating. The relay state will not change until it exceeds the nominal sensitivity by more than 25% (typically) at nominal input voltage. At which time the LED and relay contact return to the dry state. Such a condition may suggest electrode maintenance is required.

**Test Feature** Allows LLCO circuit to be tested. Holding down the reset button for 3 seconds will allow the LLCO circuit to trip which simulates the loss of water, without the need of draining the water level in the boiler. The control will return to normal operation once the reset button is pressed a second time.

26M X X X X X XX XX X

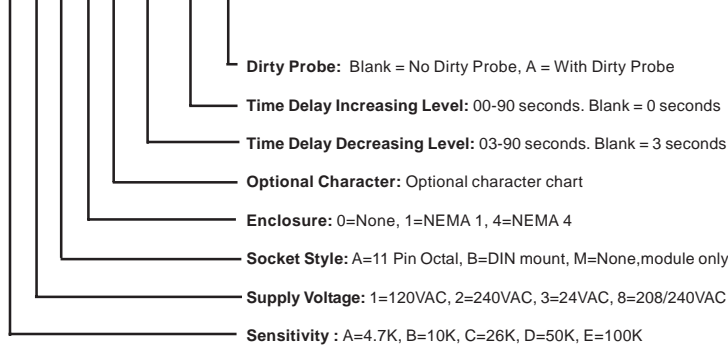

### Optional Character Chart

|   | N.C. Pushbutton | Power Outage | Test Feature |
|---|-----------------|--------------|--------------|
| A | X               | X            | X            |
| B |                 |              | X            |
| C | X               |              |              |
| E |                 | X            |              |
| F | X               | X            |              |
| Y | X               |              | X            |
| Z |                 | X            | X            |
| X | No Option       |              |              |



Gems Sensors Inc.  
 One Cowles Road  
 Plainville, CT 06062-1198  
 Tel: 860-793-4579  
 Fax: 860-793-4580

# L404F,T,V PressureTrol® Controllers

## PRODUCT DATA



## APPLICATION

L404F PressureTrol® Controllers provide operating control with automatic limit protection for pressure systems of up to 2070 kPa, or 300 psi.

L404T,V PressureTrol® Controllers are for use on oil burner systems for pressures up to 1035 kPa or 150 psi.

## FEATURES

- Models available in a series of control ranges, and pressure scales in kPa and psi.
- All models automatically reset and have an adjustable differential.
- Models have snap switch to open or close a circuit on a pressure rise.
- Case has a clear plastic cover so setpoints can be observed.
- 1/4 inch—18 NPT connection for pipe on diaphragm assembly.
- Ground screw terminal.

### L404F:

- Controllers may be used with steam, air, or noncombustible gases, or fluids noncorrosive to the pressure sensing element.

### L404T:

- High pressure limits, break a circuit on oil pressure rise above setpoint.

### L404V:

- Low pressure limits, makes a circuit on oil pressure rise above setpoint.

## Contents

|                                |   |
|--------------------------------|---|
| Application .....              | 1 |
| Features .....                 | 1 |
| Specifications .....           | 2 |
| Ordering Information .....     | 2 |
| Installation .....             | 3 |
| Settings and Adjustments ..... | 6 |
| Checkout .....                 | 6 |



## SPECIFICATIONS

### Model:

L404F,T,V PressureTrol® Controllers. See Table 1.

Table 1. Models with kPa—psi.

| Model Number           | Operating Ranges |           | Subtractive Differential <sup>a</sup> |           | Maximum Diaphragm pressure |                  |
|------------------------|------------------|-----------|---------------------------------------|-----------|----------------------------|------------------|
|                        | kPa              | psi       | kPa                                   | psi       | kPa                        | psi              |
| L404F1060              | 15 to 100        | 2 to 15   | 15 to 40                              | 2 to 6    | 170                        | 25               |
| L404F1078              | 35 to 350        | 5 to 50   | 40 to 100                             | 6 to 14   | 590                        | 85               |
| L404F1094              | 140 to 2070      | 20 to 300 | 140 to 345                            | 20 to 50  | 2410                       | 350 <sup>b</sup> |
| L404F1102              | 70 to 1035       | 10 to 150 | 70 to 150                             | 10 to 22  | 1550                       | 225              |
| L404F1219 <sup>c</sup> | 15 to 100        | 2 to 15   | 15 to 40                              | 2 to 6    | 170                        | 25               |
| L404F1243 <sup>c</sup> | 35 to 350        | 5 to 50   | 40 to 100                             | 6 to 14   | 590                        | 85               |
| L404F1227 <sup>c</sup> | 70 to 1035       | 10 to 150 | 70 to 150                             | 10 to 22  | 1550                       | 225              |
| L404F1235 <sup>c</sup> | 140 to 2070      | 20 to 300 | 140 to 345                            | 20 to 50  | 2410                       | 350 <sup>b</sup> |
| L404F1300 <sup>c</sup> | 415 to 1240      | 60 to 180 | 40 fixed                              | 6.0 Fixed | 1550                       | 225              |
| L404F1326              | 0 to 100         | 0 to 15   | 15 to 40                              | 2 to 6    | 170                        | 25               |
| L404F1334              | 0 to 350         | 0 to 50   | 40 to 100                             | 6 to 14   | 590                        | 85               |
| L404F1342              | 35 to 1000       | 5 to 145  | 70 to 150                             | 10 to 22  | 1550                       | 225              |
| L404F1359              | 70 to 2000       | 10 to 290 | 140 to 345                            | 20 to 50  | 2410                       | 350 <sup>b</sup> |
| L404F1367              | 7 to 55          | 1 to 8    | 5 to 14                               | 0.75 to 2 | 170                        | 25               |
| L404F1375 <sup>d</sup> | 35 to 350        | 5 to 50   | 40 to 100                             | 6 to 14   | 590                        | 85               |
| L404F1383 <sup>d</sup> | 70 to 1035       | 10 to 150 | 70 to 150                             | 10 to 22  | 1550                       | 225              |
| L404F1391 <sup>d</sup> | 140 to 2070      | 20 to 300 | 140 to 345                            | 20 to 50  | 2410                       | 350 <sup>b</sup> |
| L404F1409 <sup>d</sup> | 15 to 100        | 2 to 15   | 15 to 40                              | 2 to 6    | 170                        | 25               |
| L404T1055              | 35 to 350        | 5 to 50   | 40 to 100                             | 6 to 14   | 590                        | 85               |
| L404T1063              | 70 to 1035       | 10 to 150 | 70 to 150                             | 10 to 22  | 1550                       | 225              |
| L404V1087 <sup>d</sup> | 70 to 1035       | 10 to 150 | 70 to 150                             | 10 to 22  | 1550                       | 225              |
| L404V1095 <sup>d</sup> | 35 to 350        | 5 to 50   | 40 to 100                             | 6 to 14   | 590                        | 85               |

<sup>a</sup> Nominal at midscale operating range.

<sup>b</sup> Brass bellows instead of stainless steel diaphragm.

<sup>c</sup> Models with 1/4-19 BSPT thread instead of 1/4-18 NPT thread.

<sup>d</sup> Make-on-rise models with terminal B omitted for miswiring compliance.

## ORDERING INFORMATION

When purchasing replacement and modernization products from your TRADELINE® wholesaler or distributor, refer to the TRADELINE® Catalog or price sheets for complete ordering number.

If you have additional questions, need further information, or would like to comment on our products or services, please write or phone:

1. Your local Honeywell Automation and Control Products Sales Office (check white pages of your phone directory).
2. Honeywell Customer Care  
1885 Douglas Drive North  
Minneapolis, Minnesota 55422-4386

In Canada—Honeywell Limited/Honeywell Limitée, 35 Dynamic Drive, Scarborough, Ontario M1V 4Z9.

International Sales and Service Offices in all principal cities of the world. Manufacturing in Australia, Canada, Finland, France, Germany, Japan, Mexico, Netherlands, Spain, Taiwan, United Kingdom, U.S.A.

Table 2. Conversion Table.

| Operating Range Conversions |             |           | Subtractive Differential Conversions |            |          |
|-----------------------------|-------------|-----------|--------------------------------------|------------|----------|
| kg/cm <sup>2</sup>          | kPa         | psi       | kg/cm <sup>2</sup>                   | kPa        | psi      |
| 0.1 to 1.05                 | 15 to 100   | 2 to 15   | 0.15 to 0.4                          | 15 to 40   | 2 to 6   |
| 0.4 to 3.5                  | 35 to 350   | 5 to 50   | 0.4 to 1.0                           | 40 to 100  | 6 to 14  |
| 0.7 to 10.0                 | 70 to 1035  | 10 to 150 | 0.7 to 1.6                           | 70 to 150  | 10 to 22 |
| 1.5 to 20.0                 | 140 to 2070 | 20 to 300 | 1.5 to 3.5                           | 150 to 300 | 20 to 50 |

Table 3. Switch Ratings (Amperes).

| Switch State | 120 Vac | 240 Vac |
|--------------|---------|---------|
| Full Load    | 8.0     | 5.1     |
| Locked Rotor | 48.0    | 30.6    |

**Pressure Sensing Element:** Stainless steel diaphragm (140 to 2070 kPa models) has brass bellows.

**Maximum Ambient Temperature:** 66°C (150°F). Also, refer to note under Mounting.

**Adjustment Means:** Screws on top of control case. Scales are marked in psi or kPa.

**Mounting Means:** 1/4 inch-18 NPT connection on diaphragm assembly; or surface mounts using holes in back of case.

**Dimensions:** See Fig. 1.

**Switching Action:** Snap switch breaks R-B (closes R-W) on pressure rise. Make-on-rise devices omit terminal B.

**Grounding Means:** Ground screw terminal marked with a circled ground symbol.

**Accessories:**

14026 Steam Trap (118023 for BSPT models).  
 33312B Knurled Knob—fits on top of adjusting screws.  
 129564 Range Stop—range stop screw, Part No. 107194, and wrench, Part No. 23466, to limit setpoint range.

**Approvals:**

Underwriters Laboratories Inc. Listed: file no. MP466, vol. 10, guide no. MBPR.  
 Canadian Standard Association certified: file no. LR1620, guide no. 400E-0.

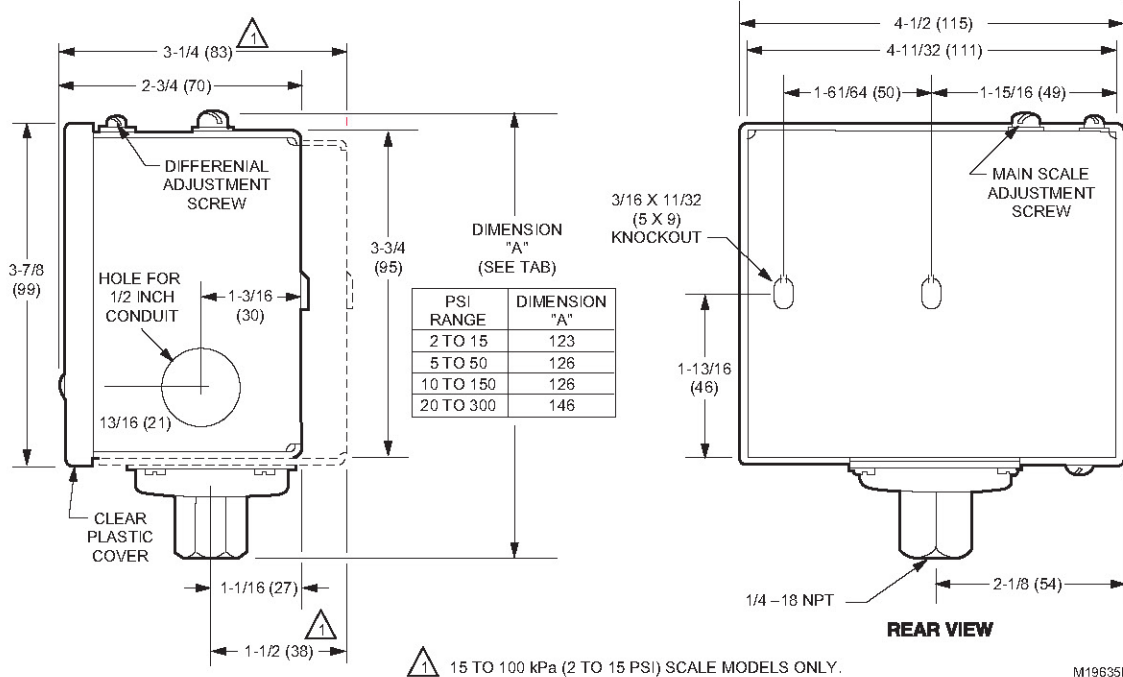

Fig. 1. L404F,T,V approximate dimensions in inches (millimeters in parentheses).

## INSTALLATION

### When Installing This Product...

1. Read these instructions carefully. Failure to follow them could damage the product or cause a hazardous condition.

2. Check on the ratings given in the instructions and marked on the product to make sure the product is suitable for your application.
3. Installer must be a trained, experienced service technician.

- After installation is complete, check out the product operation as provided in these instructions.

**IMPORTANT**

When making pipe connections, use pipe dope sparingly to seal the joints; any excess dope may clog the small hole in the fitting and prevent the controller from operating properly.

**Location and Mounting (L404F)**

Locate the L404F where the ambient temperature will not exceed 66°C (150°F). The L404F can be mounted near the pressure gauge, at a remote location, in a fitting provided by the boiler manufacturer, or in a special mounting on low water cutoffs. The L404F should always be mounted above the water line in steam boiler applications.

NOTE: For accurate operation, supplemental heat should be added to installations where temperatures fall below -29°C (-20°F).

A steam trap must be connected between the L404F and the boiler (see Fig. 2) to prevent boiler scale and corrosive vapors from attacking the elbows or diaphragm.

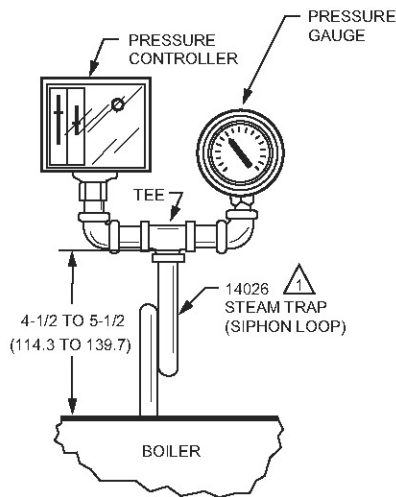

▲ 1/4 IN. BLACK IRON PIPE WITH 1/4 - 18 NPT EXTERNAL THREADS ON BOTH ENDS AND 2-1/4 IN. DIAMETER LOOP. M6934B

**Fig. 2. Steam trap mounting.**

**Pressure Gauge Mounting**

To mount beside a pressure gauge, remove the gauge, and install in its place the steam trap with a tee on top. Mount the PressureTrol® unit and pressure gauge on the side of the tee by means of nipples and elbows (see Fig. 2).

**Remote Mounting**

Excessive vibration at the boiler may affect the operation of the L404F. In these cases, the L404F should be remotely located, subject to the following:

- All piping must be suitable and properly pitched to drain all condensation back to the boiler.
- The remote mounting must be solid.
- A steam trap must be used at one end of the piping.

**Boiler Mounting**

If it is not convenient to mount the L404F adjacent to the pressure gauge, install a steam trap at the location recommended by the boiler manufacturer, then screw the device directly to the steam trap.

**Location and Mounting (L404T,V)**

**Location**

NOTE: For most accurate operation, supplemental heat should be added to installations where the temperature falls below -20°F (-29°C). These controllers can be mounted at any location in the oil supply line, depending on the application. Typical locations are shown in Fig. 3. The low oil pressure controller should be located upstream from the safety shutoff valve(s). In a downstream location, there would be zero pressure when the burner is not running and the safety shutoff valve(s) is (are) closed. This could prevent startup or require manual reset every time the burner is started. The high oil pressure controller should be located as near to the burner as possible.

**Mounting**

Mount the oil pressure controller directly on the main pipe. Insert a tee in the pipe line, and connect a pipe nipple of appropriate size to the tee (see Fig. 4). Screw the hexagonal fitting (1/4-18 NPT internal thread) of the pressure controller to the pipe nipple. To avoid leaks and damage to the case, use a parallel jaw wrench on the hexagonal fitting close to the pipe nipple. Do not tighten the pressure controller by hand by holding the case.

Make all pipe connections in accordance with approved standards. Use only a small amount of pipe compound to seal the connection joints. Excess pipe compound may clog the orifice in the pipe fitting and prevent the controller from operating properly.

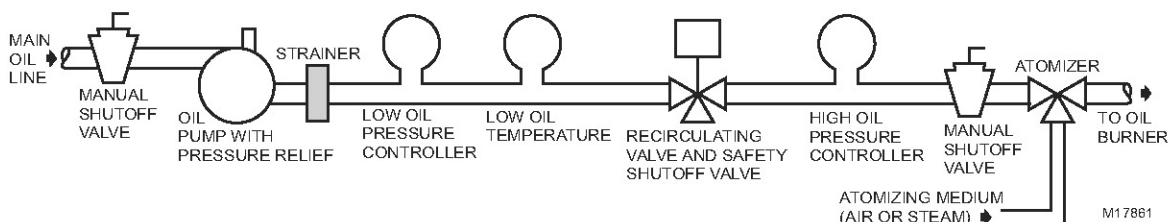

**Fig. 3. Typical locations of pressure controllers in an oil burner system.**

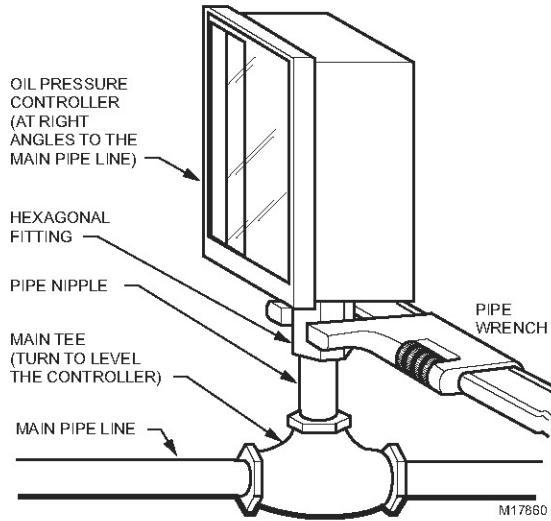
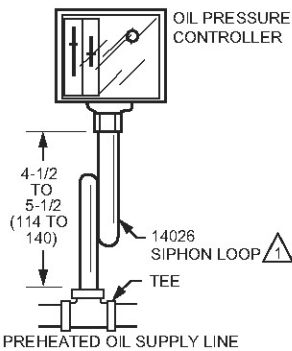

Fig. 4. Mounting an oil pressure controller directly on the main pipe.

### Using with Preheated Oil

When used with preheated oil, a siphon loop (part number 14026) must always be connected between the controller and the main pipe (see Fig. 5) to provide thermal buffering.



1 1/4 INCH BLACK IRON PIPE WITH 1/4-18 NPT EXTERNAL THREADS ON BOTH ENDS AND 2-1/4 IN. (57 MM) DIAMETER LOOP. M17858A

Fig. 5. Mounting of a siphon loop, with approximate dimensions in in. (mm).

## WIRING

### ⚠ WARNING

**Electrical Shock Hazard.**  
 Can cause severe injury, death or property damage.  
 Disconnect the power supply before beginning wiring.  
 More than one power supply disconnect may be required.

All wiring must comply with applicable codes and ordinances. All models have terminals (on the MicroSwitch® snap-acting switch) inside the cover and knockouts for conduit and cable. Refer to manufacturer installation and wiring instructions, if available, and to typical hookups shown in Fig. 6 to 10.

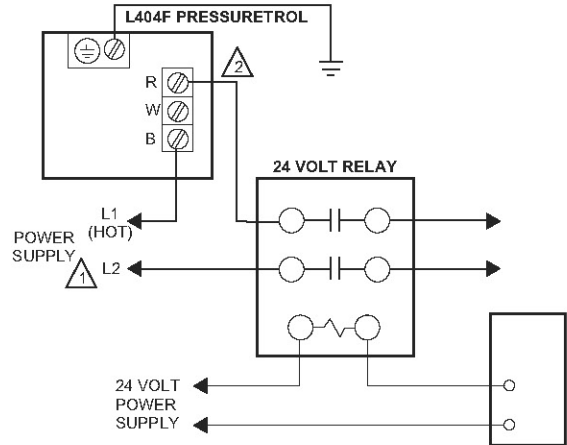

1 PROVIDE DISCONNECT MEANS AND OVERLOAD PROTECTION AS REQUIRED.  
 2 AS SHOWN, SWITCH OPENS ON PRESSURE RISE. REVERSE ACTING (MAKE ON PRESSURE RISE) UNITS ARE WIRED TO R-W TERMINALS AND TERMINAL B IS OMITTED. M19637A

Fig. 6. L404F in low voltage relay circuit.

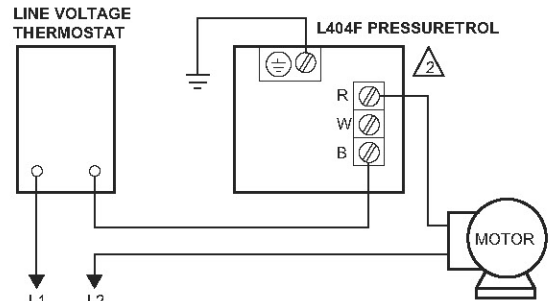

1 PROVIDE DISCONNECT MEANS AND OVERLOAD PROTECTION AS REQUIRED.  
 2 AS SHOWN, SWITCH OPENS ON PRESSURE RISE. REVERSE ACTING (MAKE ON PRESSURE RISE) UNITS ARE WIRED TO R-W TERMINALS AND TERMINAL B IS OMITTED. M19638A

Fig. 7. L404F in a typical 2-wire control circuit.

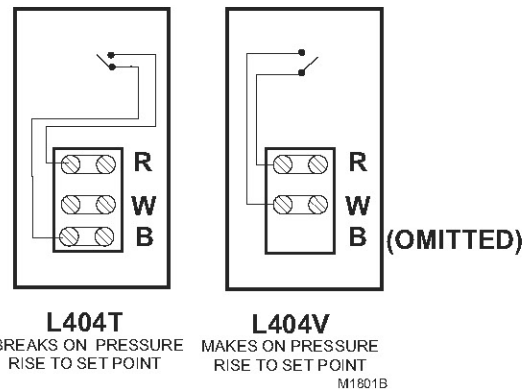
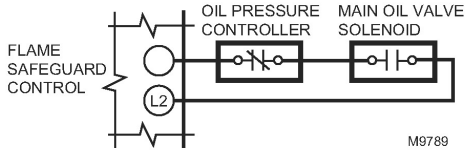
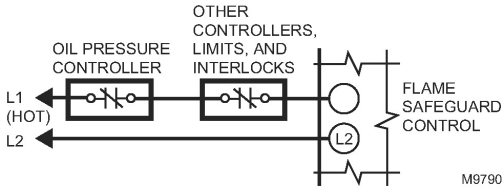

Fig. 8. L404T, V terminal blocks and internal schematics.



**Fig. 9. Hookup of an oil pressure controller used on a single burner system with an integral oil pump.**



**Fig. 10. Hookup of an oil pressure controller used on a single burner or multiburner system with an external oil pump.**

## SETTINGS AND ADJUSTMENTS

When the pressure at the control rises above the L404 setpoint, a circuit opens between the R-B terminals. During a pressure fall, R-B will close at the setpoint pressure minus the switch differential.

For example, if a controller is set to differential **B** (see Fig. 11) with a controller setpoint of **A**, R-B will open when the pressure rises to **A**. Then during a pressure fall, the R-B terminals will close when the pressure drops to **C** (**A** minus differential **B**).

For make on rise applications, the switch is wired to R-W terminals. The R-W circuit will close on pressure rise to the setpoint. R-W will open again on a pressure drop past the switch differential.

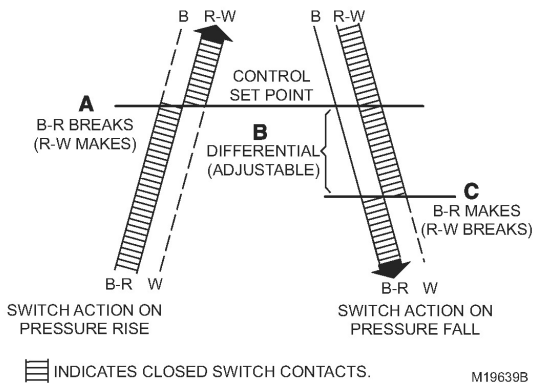
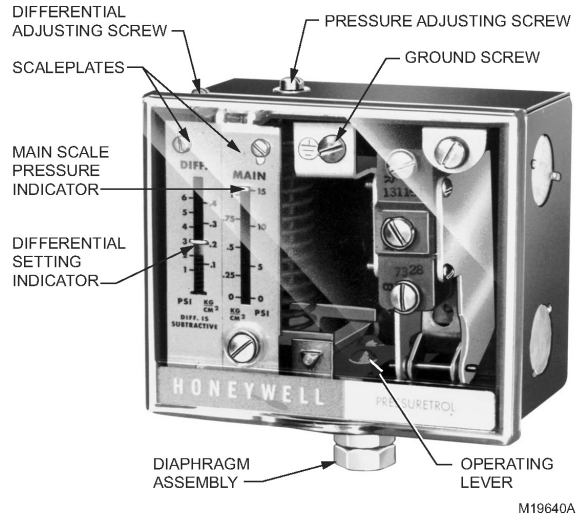

**Fig. 11. Operation of switch on pressure rise and fall.**

## Setpoint Adjustment

Turn the pressure adjusting screw on the top of the controller (Fig. 12) to adjust the setpoint. Turn the differential adjusting screw to the desired pressure difference between switch opening and switch closing.

**NOTE:** When the main scale setting is at the lower end of the operating range, the differential range will be less than the differential setting by approximately 20 percent.



**Fig. 12. view of L404 PressureTrol® Controller.**

## Scaleplate Adjustment

The L404F,T,V has been carefully calibrated during manufacture and should not require recalibration.

However, if recalibration is necessary, remove the cover and loosen the setscrews which hold the scaleplate. Adjust the plate up or down, as required, to bring the device into calibration. Tighten the setscrews securely and replace the cover.

## CHECKOUT

After the controller has been installed, wired and adjusted, it should be tested with the system in operation. First, allow the system to stabilize. Then, observe the operation of the controller while raising and lowering its setpoint. Pressure should increase when the setpoint is raised and decrease when the setpoint is lowered.

Also, check the make and break points of the controller. If they do not agree with a separate, accurately calibrated pressure gauge, a slight adjustment of the scaleplate(s) may be necessary.

Use accurate pressure testing equipment when checking out the controller. Do not rely on inexpensive gauges. The controllers are carefully calibrated at the factory.

## L4079A,B,W PressureTrol® Limit Control

PRODUCT DATA



### FEATURES

- L4079A has two ganged spst switches; breaks two circuits (may be both sides of the power supply) simultaneously.
- L4079B has one spst switch.
- L4079W is the same as L4079B, but with seals for oil applications.
- MICRO SWITCH® snap-acting switches are visible through transparent cover.
- Switches open automatically, but must be reset manually.
- Trip-free reset mechanisms do not permit the limiting role of the PressureTrol® Control to be defeated by jamming the reset lever.
- Control does not need leveling.
- The L4079 is unaffected by moderate vibration.

### APPLICATION

The L4079A,B, and W PressureTrol® Limit Controls are high pressure limit switches which break electrical circuits when pressure rises to a preset value.

The L4079A and B can be used with steam, air, noncombustible gases, and fluids noncorrosive to the sensing element.

L4079W is for use on oil burner systems.

### Contents

|                      |   |
|----------------------|---|
| Application .....    | 1 |
| Features .....       | 1 |
| Specifications ..... | 2 |
| POUR COMMANDER ..... | 2 |
| French               |   |
| Installation .....   | 3 |
| Wiring .....         | 3 |



# SPECIFICATIONS

**Models:** Pressure and Electrical Specifications: See Table 1.

**Table 1. Pressure and Electrical Ratings.**

| Model Number                                | Range     |             | Maximum Diaphragm Pressure |      | Ratings in Amperes |              |           |              |
|---|-----------|-------------|----------------------------|------|--------------------|--------------|-----------|--------------|
|   |           |             |                            |      | 120 Vac            |              | 240 Vac   |              |
|   | psi       | kPa         | psi                        | kPa  | Full Load          | Locked Rotor | Full Load | Locked Rotor |
| L4079A <sup>a</sup> and L4079B <sup>b</sup> | 2 to 15   | 15 to 100   | 25                         | 170  | 9.8                | 58.8         | 4.9       | 29.4         |
|   | 5 to 50   | 35 to 350   | 85                         | 590  | 9.8                | 58.8         | 4.9       | 29.4         |
|   | 10 to 150 | 70 to 1035  | 225                        | 1550 | 9.8                | 58.8         | 4.9       | 29.4         |
| L4079B1066 <sup>b</sup>                     | 20 to 300 | 140 to 2070 | 350                        | 2410 | 9.8                | 58.8         | 4.9       | 29.4         |
| L4079W1000 <sup>b</sup>                     | 10 to 150 | 70 to 1035  | 225                        | 1550 | 9.8                | 58.8         | 4.9       | 29.4         |

<sup>a</sup> Ratings apply to each of two separate circuits.

<sup>b</sup> One circuit only.

**Switching Action:**

L4079A—Snap-switch. Breaks two circuits automatically on pressure rise. Each circuit must be manually reset.

L4079B,W—Snap-switch. Breaks one circuit automatically on pressure rise. Circuit must be manually reset.

**Adjustment means:** External adjustment screw. Scale is calibrated in psi and kPa.

**Maximum Ambient Temperature:** 150°F (66°C).

**Mounting Means:**

Pipe fitting—1/4-18 NPT. Steam trap for mounting furnished on some models. These devices may be either boiler mounted directly to a boiler fitting, or may be surface mounted, such as on a wall, by using the knockouts in the case.

**Approvals:**

Underwriters Laboratories Inc. (UL) Listed: File No. MP466, Guide No. MBPR.

Canadian Standards Association (CSA): File No. LR95329, Certificate No. 1720340

**Accessories:**

14026 Steam Trap.

33312B Knurled adjustment knob.

**Dimensions:** See Fig. 1.

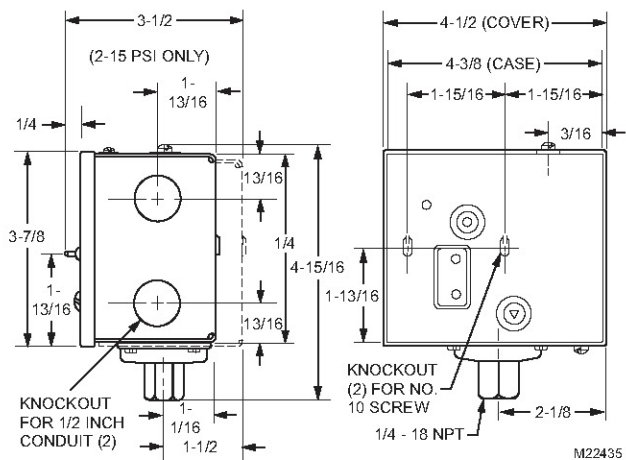

**Fig. 1. L4079A,B,W PressureTrol® Limit Control dimensions in inches.**

# ORDERING INFORMATION

When purchasing replacement and modernization products from your TRADELINE® wholesaler or distributor, refer to the TRADELINE® Catalog or price sheets for complete ordering number.

If you have additional questions, need further information, or would like to comment on our products or services, please write or phone:

1. Your local Honeywell Automation and Control Products Sales Office (check white pages of your phone directory).
2. Honeywell Customer Care  
1885 Douglas Drive North  
Minneapolis, Minnesota 55422-4386

In Canada—Honeywell Limited/Honeywell Limitée, 35 Dynamic Drive, Scarborough, Ontario M1V 4Z9.

International Sales and Service Offices in all principal cities of the world. Manufacturing in Australia, Canada, Finland, France, Germany, Japan, Mexico, Netherlands, Spain, Taiwan, United Kingdom, U.S.A.

# INSTALLATION

## When Installing This Product...

1. Read these instructions carefully. Failure to follow them could damage the product or cause a hazardous condition.
2. Check on the ratings given in the instructions and marked on the product to make sure the product is suitable for your application.
3. Installer must be a trained, experienced service technician.
4. After installation is complete, check out the product operation as provided in these instructions.

## Location

PressureTrol® Limit Controllers must be mounted above the water line in steam boilers. They can be mounted alongside the pressure gauge, at a remote location, in a fitting provided by the boiler manufacturer, or in special mountings on low-water cutoffs.

## Mounting

See Fig. 1 for mounting dimensions.

A steam trap must always be connected between the PressureTrol® unit and the boiler. The steam trap prevents boiler scale and corrosive vapors from attacking the diaphragm.

## Pressure Gauge Mounting:

To mount the limit control beside a pressure gauge, remove the gauge and install in its place a steam trap with a tee on top. Mount the PressureTrol® unit and pressure gauge on the side of the tee by means of nipples and elbows.

## Remote Mounting:

If excessive vibration seems likely to affect the operation of the control, it may be located remotely, as long as all piping is suitable and properly pitched to drain all condensation back to the boiler.

## Boiler Mounting:

If it is not convenient to mount the control adjacent to the pressure gauge, install a steam trap at a location on the boiler recommended by the boiler manufacturer and screw the unit directly to the steam trap.

# WIRING

## ⚠ WARNING

**Electrical Shock Hazard.**  
**Can cause severe injury, death or property damage.**  
 Disconnect the power supply before beginning wiring.  
 More than one power supply disconnect may be required.

All wiring must comply with local codes and ordinances. See Fig. 2 for internal schematics and wiring.

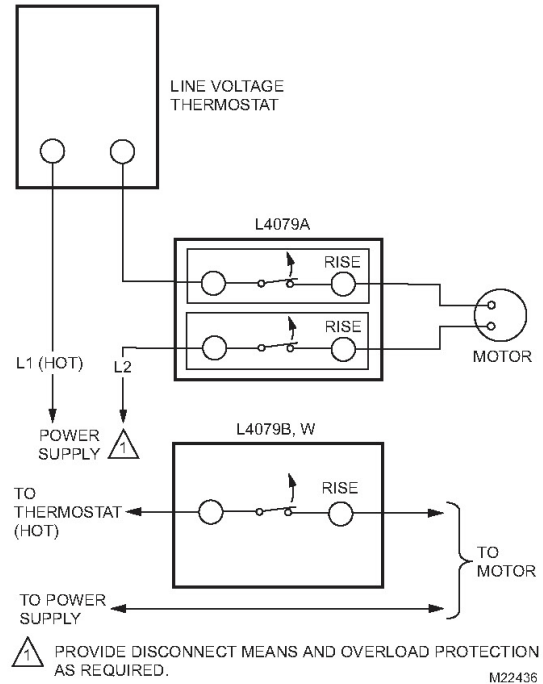

**Fig. 2. Schematics and wiring. L4079A breaks both sides of power supply; L4079B,W breaks hot side only.**

## Setting

To set the control, turn the pressure adjusting screw (see Fig. 3) until the pressure setting indicator on the front of the case is in line with the required control pressure setpoint. The indicator setting is the point at which the switch breaks contact.

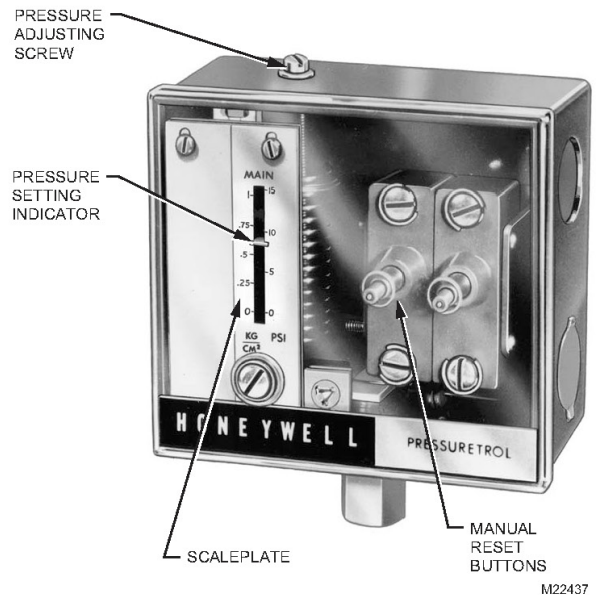

**Fig. 3. Controls and indicators on L4079A. L4079B,W is the same except for having only one reset button.**

## Manual Resetting

When the circuits have broken automatically, they must be manually reset. After the pressure returns to normal, manually reset by depressing the manual reset button(s) firmly and releasing. The circuit is not complete until the reset button is released. The trip-free manual reset mechanism prevents the limit controller from operating as an automatic controller (self-resetting) even if the manual reset button has been tied down.

## CHECKOUT

After the control has been installed and wired, test as follows:

Note the boiler pressure by checking the boiler pressure gauge (boiler pressure should be near the middle of the PressureTrol® pressure scale to perform this test properly).

Rotate the PressureTrol® pressure adjusting screw (see Fig. 3) until the pressure setting indicator on the front of the case corresponds to the boiler pressure gauge reading.

The limit control should break the control circuit(s) when the boiler pressure gauge reading equals or slightly exceeds the PressureTrol® pressure setting.

If the limit control is operating properly, manually reset it and adjust the pressure adjusting screw until the pressure setting indicator is in line with the required limit setpoint.

### Automation and Control Solutions

Honeywell International Inc.  
1985 Douglas Drive North  
Golden Valley, MN 55422  
customer.honeywell.com

Honeywell Limited-Honeywell Limitée  
35 Dynamic Drive  
Scarborough, Ontario M1V 4Z9



## LATTNER BOILER LIMITED WARRANTY

A Lattner boiler shell is guaranteed to be constructed in accordance with the ASME Code. An independent ASME boiler inspector inspects the construction of each boiler and: (1) checks mill test reports on all materials used to ensure that the chemical and physical analysis of such materials complies with the ASME Code; (2) inspects each boiler shell during construction to see that workmanship complies with the Code; and (3) witnesses the final hydrostatic test and then places the ASME stamp on the boiler shell and signs an ASME data report certifying the boiler is ASME approved.

Lattner warrants the boiler and any other equipment of its manufacture to be free from defects in material and workmanship for one (1) year from the date of shipment from the factory, provided the boiler is operated under the normal use and service for which it was intended, and only if the boiler has been properly installed by a qualified technician in accordance with but not limited to ASME, ANSI, and NFPA Codes and applicable local, state, and national codes.

Lattner's obligation under this Warranty is limited, at Lattner's option, to replacing or repairing any defective part of the boiler or other equipment it manufactures. No allowance will be made for labor, transportation, or other charges incurred in the replacement or repair of defective parts. Merchandise not manufactured by the Company, supplied in one piece or in component assemblies, is not covered by the above warranty, but the Company will give the Purchaser the benefit of such adjustment as it can make with the manufacturer of such items.

Lattner shall not be liable for special, indirect, or consequential damages. Lattner shall not be liable for any loss or damage resulting, directly or indirectly, from the use or loss of use of the boiler. This exclusion from liability includes the Purchaser's expenses for downtime or for making up downtime, damages for which the Purchaser may be liable to other persons, or damages to property.

The remedies set forth in this Warranty are exclusive, and the liability of Lattner with respect to any contract or sale shall not exceed the cost of repair or replacement of the boiler or other equipment manufactured by Lattner.

The above Warranty shall not apply to any boiler or other equipment manufactured by Lattner which:

- 1) has been repaired or altered without Lattner's written consent;
- 2) has been altered in any way so as, in the judgment of Lattner, to adversely affect the stability or reliability of the boiler;
- 3) has been subject to improper water treatment, scale, corrosion, misuse, negligence, or accident;
- 4) has not been operated in accordance with Lattner's printed instructions or specifications;
- 5) has been operated under conditions more severe than or otherwise exceeding those set forth in the specifications for such boiler; or
- 6) has not been properly installed by a qualified technical in accordance with but not limited to ASME, ANSI and NFPA Codes and all applicable local, state and national codes.

**THIS WARRANTY IS EXPRESSLY MADE IN LIEU OF ALL OTHER WARRANTIES, EXPRESS OR IMPLIED. LATTNER MAKES NO WARRANTY OF MERCHANTABILITY OR OF FITNESS FOR ANY PARTICULAR PURPOSE.**

Purchaser must notify Lattner of a breach of Warranty within thirty (30) days after discovery thereof, but not later than the one-year guarantee period; otherwise, such claims shall be deemed waived. No allowance will be granted for any repairs or alterations made by Purchaser without Lattner's prior verbal or written consent. Items returned to Lattner must be accompanied by a factory-supplied return goods authorization (RGA). **Such authorization may be obtained by calling the factory at 319/366-0778 or by writing to P.O. Box 1527, Cedar Rapids, IA 52406.**

Lattner neither assumes nor authorizes any person to assume for it any other liability in connection with the sale or use of the boiler or other equipment manufactured by Lattner, and there are no oral agreements or warranties collateral to or affecting this Agreement.

**LATTNER BOILER COMPANY**  
Cedar Rapids, IA USA

# STANDARD TERMS & CONDITIONS

## LIMITATION ON QUOTATION

Unless otherwise stated in the quotation, the quotation will remain valid for a period of thirty (30) days from the date hereof, at which time it will automatically expire unless extended by a signed document issued by the Company, from its headquarters in Cedar Rapids, IA.

## EQUIPMENT SELECTION

The Purchaser's selection of sizes, types, capacities, and specifications and suitability thereof for the specific application shall be the unshared responsibility of the Purchaser or Purchaser's representative or consultant.

## PERMISSIBLE VARIATIONS, STANDARDS, AND TOLERANCES

Except in the particulars specified by the Purchaser and expressly agreed to in writing by the Company, all materials shall be produced in accordance with the Company's standard practices. The Company reserves the right to deviate from tolerances and variations in the equipment without notice, provided that the substitute part(s) or deviation(s) are consistent with the usage and performance of the product.

## PRICES

Unless defined otherwise in the quotation, prices are F.O.B. Cedar Rapids, IA USA, exclusive of freight, storage, off-loading, installation, service, start-up, extended warranty or local delivery charges, if any.

## TAXES

Purchaser shall be liable for all Federal, State, and local taxes with respect to the purchase of the equipment proposed, unless exclusively exempted from any taxes and proof thereof is on file with the Company.

## PAYMENT

Purchaser shall pay with US funds, the full amount of the invoiced purchase price within thirty (30) days of the Company's invoice, whether the equipment has shipped or has been delayed through no fault of the Company and subject to approved credit. Beginning thirty (30) days after the invoice date, Purchaser shall pay a late payment charge of two percent (2%) per month, which is an annual rate of 24%, on any unpaid portion of the purchase price. The Company reserves the right to revoke or modify these credit terms.

## SHIPMENT

Any shipping date shown in the body of the quotation or order acknowledgement, represents the Company's approximated schedule as of the date of the quotation, and is subject to change as determined by shop loading if and when this quotation should be realized as an actual sale. The Company shall not incur any liability of any kind for failure to ship on any particular date unless a firm shipping date has been expressly agreed to by an officer of the Company, in a separate written document.

## CANCELLATION AND DELAYS

Subsequent to the receipt of Purchaser's Purchase Order and the Company's issued order acknowledgement, the Purchaser may not change or cancel the order in whole or in part without the written approval and acceptance by the Company of such cancellation or change. The Company may condition its approval of a change or cancellation upon a price change to reflect the Company's cost to implement the change, or to offset costs incurred by the Company in order preparation, engineering, purchasing, or in actual production of the order. In the event that the Purchaser delays shipment of the equipment upon the Company's notice to ship, the equipment shall be placed in storage at the Purchaser's risk and expense, and shall be invoiced as if shipped.

## RETURNS AND RESTOCKING

Equipment may be returned to Lattner at 1411 9<sup>th</sup> Street SW, Cedar Rapids, IA 52404, only upon prior written authorization of the Company. Consent, if given, will be upon the condition the Purchaser assumes all carrier charges, responsibility for damages in transit, and a minimum

15% restocking charge, and only if the authorized material is in new and unused condition and returned within one year from original date of shipment. The credit will be based on the original invoice price or the current price; whichever is lower, less the applicable restocking charge.

## SECURITY INTEREST

For the purposes of securing payment, the Company may issue a lien on the equipment, for past due accounts, until such time that payment has been received in full. Upon receipt of payment in full, the Company will rescind the lien.

## FORCE MAJEURE

In no event shall the Company be liable for loss or damage resulting from any delay or failure to ship or other failure, loss, or damage that is the proximate result of any act of government authority, revolution, riot, civil disorder, act of war, delay or default in transportation, inability to obtain materials or facilities from normal sources, fire, flood, act of God, or any cause not within the reasonable control of the Company. The Company may, without causing a breach or incurring liability, allocate goods which are in short supply irrespective of the reasons therefore among customers in any manner which the Company in its sole discretion deems advisable. If an event occurs that is beyond the control of the Company, and that event delays the Company's performance and causes its cost of production to increase because of the delay, the Company may pass such increased cost(s) on to the Purchaser.

## DAMAGE LIMITATION

Under no circumstance shall the Company be held liable for any loss of profits, down time, or any incidental or consequential damages of any kind with respect to its products or the transaction by which its products are sold.

## WARRANTY AND PERFORMANCE

Products shall be warranted in accordance with the Company's standard warranty statement, form No. 2-98-R06. The Company's warranty shall be voided by any abuse, misuse, neglect, unauthorized modification or service, lack of maintenance and service, or use not in accordance with the Company's instructions. Warranty shall also be voided if water treatment has not been provided or by improper start-up of the equipment. The Company's warranty statement and this paragraph contain the Company's sole warranty and the Company makes no implied warranty, and there is no implied warranty of merchantability or fitness for any particular purpose.

## SERVICE

Unless otherwise noted herein, the cost of the equipment does not include service or installation. All services performed by the Company are subject to the Purchaser's payment of the Company's prevailing charges plus necessary travel and living expenses. Whenever service is quoted, please refer to Lattner's Service Policy for specific details.

## EXCLUSION OF OTHER TERMS

This constitutes an offer on behalf of Lattner Boiler Manufacturing (the Company); to sell the goods described in the quotation, exclusively on the terms and conditions stated. Acceptance of this by the Purchaser is hereby expressly limited to these Terms and Conditions and shall be applicable to any order issued by the Purchaser unless other terms have been agreed to in a written document issued by the Company.

## GOVERNING LAW

The transaction with respect to the goods, which are subject hereof, shall be governed by, interpreted, and construed in accordance with the laws of the State of Iowa. The Courts in the State of Iowa will have the sole jurisdiction over any claim arising under this contract of sale.

## ASSIGNMENT

All sales as evidenced by the Company's acknowledgement shall be binding upon and insure to the benefit of the Purchaser and the Company and their respective heirs, successors, or assigns.

**LATTNER BOILER COMPANY**  
Cedar Rapids, IA USA

TC06