



ModCon

Volume Water Heaters

Installation

Start-Up

Maintenance

Parts

Warranty

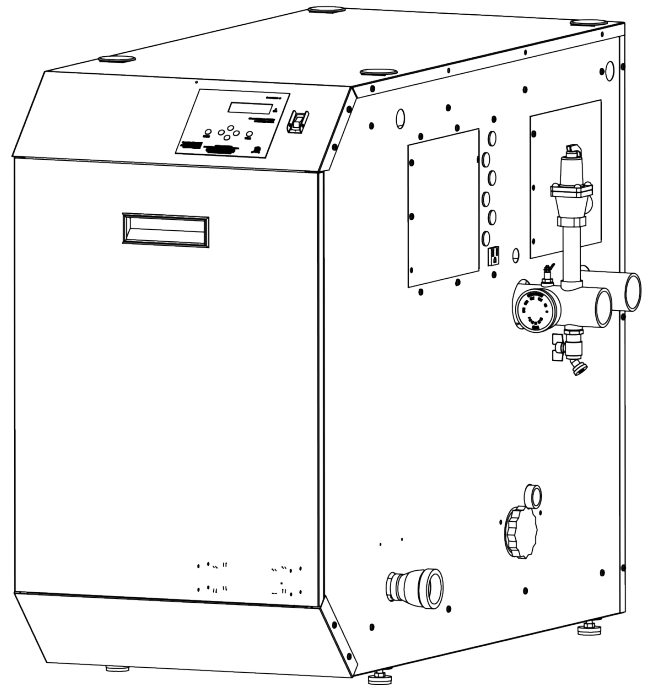

MODCON500 / 700 / 850VWH Models*

*"VWH" Denotes Hot Water Supply Boiler

"LP" Denotes Propane Gas Operation

"HL" Denotes Installed High and Low Gas Pressure Switches

"WL" Denotes Installed High Temperature Water Limit

**This Manual For Use With Boilers Manufactured
After August 13, 2013**

Heat Exchanger Bears the ASME "H" Stamp



! DANGER
This manual must only be used by a qualified installer / service technician. Read all instructions in this manual before installing. Perform steps in the given order. Failure to do so could result in substantial property damage, severe personal injury, or death.
! WARNING
Improper installation, adjustment, alteration, service, or maintenance could void product warranty and cause property damage, severe personal injury, or death.
California Proposition 65 Warning: This product contains chemicals known to the State of California to cause cancer, birth defects, or other reproductive harm.
NOTICE
HTP reserves the right to make product changes or updates without notice and will not be held liable for typographical errors in literature.
The surfaces of these products contacted by potable (consumable) water contain less than 0.25% lead by weight as required by the Safe Drinking Water Act, Section 1417.
NOTE TO CONSUMER: PLEASE KEEP ALL INSTRUCTIONS FOR FUTURE REFERENCE.

! WARNING

WARNING: If the information in these instructions is not followed exactly, a fire or explosion may result causing property damage, personal injury or death.

- Do not store or use gasoline or other flammable vapors and liquids in the vicinity of this or any other appliance.

WHAT TO DO IF YOU SMELL GAS

- Do not try to light any appliance.
- Do not touch any electrical switch; do not use any phone in your building.
- Immediately call your gas supplier from a neighbor's phone. Follow the gas supplier's instructions.
- If you cannot reach your gas supplier, call the fire department.
- Installation and service must be provided by a qualified installer, service agency or the gas supplier.

Improper installation, adjustment, alteration, service, or maintenance can cause injury, property damage, or death. Refer to this manual. Installation and service must be performed by a qualified installer, service agency, or gas supplier.

FOR YOUR SAFETY READ BEFORE OPERATING

WARNING: If you do not follow these instructions exactly, a fire or explosion may result, causing property damage, personal injury or loss of life.

- A.** This appliance does not have a pilot. It is equipped with an ignition device which automatically lights the burner. Do not try to light the burner by hand.
- B.** BEFORE OPERATING smell all around the appliance area for gas. Be sure to smell next to the floor because some gas is heavier than air and will settle on the floor.
- WHAT TO DO IF YOU SMELL GAS**
- Do not try to light any appliance
 - Do not touch any electric switch; do not use any phone in your building
 - Immediately call your gas supplier from a neighbor's phone. Follow the gas suppliers' instructions.
- C.** Use only your hand to turn the gas control knob. Never use tools. If the handle will not turn by hand, don't try to repair it, call a qualified service technician. Force or attempted repair may result in a fire or explosion.
- D.** Do not use this appliance if any part has been under water. Immediately call a qualified service technician to inspect the appliance and to replace any part of the control system and any gas control which has been under water.
- E.** If you cannot reach your gas supplier, call the fire department.

OPERATING INSTRUCTIONS

- STOP! Read the safety information above.
- Set the thermostat to lowest setting.
- Turn off all electric power to the appliance.
- This appliance is equipped with an ignition device which automatically lights the burner. Do not try to light the burner by hand.
- Remove front cover.
- Turn gas shutoff valve to "off". Handle will be across the piping, do not force.
- Wait five (5) minutes to clear out any gas. If you then smell gas, STOP! Follow "B" in the safety information above on this label. If you don't smell gas, go to next step.
- Turn gas shutoff valve to "on". Handle will be in line with piping.
- Install Front Cover.
- Turn on all electric power to appliance.
- Set thermostat to desired setting.
- If the appliance will not operate, follow the instructions "To Turn Off Gas To Appliance" and call your service technician or gas supplier.

GAS VALVE
ON

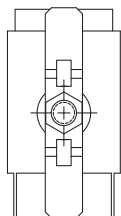

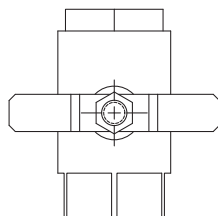

GAS VALVE
OFF



TO TURN OFF GAS TO APPLIANCE

- Set the thermostat to lowest setting.
- Turn off all electric power to the appliance if service is to be performed.
- Remove Front Cover.
- Turn gas shutoff valve to "off". Handle will be across the piping. Do not force.
- Install Front Cover.

SPECIAL ATTENTION BOXES	
The following defined terms are used throughout this manual to bring attention to the presence of hazards of various risk levels or to important product information.	
	DANGER
DANGER indicates an imminently hazardous situation which, if not avoided, will result in serious personal injury or death.	
	WARNING
WARNING indicates a potentially hazardous situation which, if not avoided, could result in personal injury or death.	
	CAUTION
CAUTION indicates a potentially hazardous situation which, if not avoided, may result in moderate or minor personal injury.	
CAUTION	
CAUTION used without the safety alert symbol indicates a potentially hazardous situation which, if not avoided, may result in property damage.	
NOTICE	
NOTICE is used to address practices not related to personal injury.	

Foreword

This manual is intended to be used in conjunction with other literature provided with the boiler. This includes all related control information. It is important that this manual, all other documents included in this system, and additional publications including the *National Fuel Gas Code - ANSI Z223.1* (latest versions), be reviewed in their entirety before beginning any work.

Installation should be made in accordance with the regulations of the Authority Having Jurisdiction, local code authorities, and utility

companies which pertain to this type of water heating equipment. Authority Having Jurisdiction (AHJ) – The AHJ may be a federal, state, local government, or individual such as a fire chief, fire marshal, chief of a fire prevention bureau, labor department or health department, building official or electrical inspector, or others having statutory authority. In some circumstances, the property owner or his/her agent assumes the role, and at government installations, the commanding officer or departmental official may be the AHJ.

NOTE: HTP reserves the right to modify product technical specifications and components without prior notice.

For the Installer

This boiler must be installed by qualified and licensed personnel. The installer should be guided by the instructions furnished with the boiler, and by local codes and utility company requirements. In the absence of local codes, preference should be given to the *National Fuel Gas Code - ANSI Z223.1*, latest version.

Installations Must Comply With:

Local, state, provincial, and national codes, laws, regulations, and ordinances.

The latest version of the *National Fuel Gas Code, ANSI Z223.1*, from American Gas Association Laboratories, 8501 East Pleasant Valley Road, Cleveland, OH 44131.

In Canada - *CGA No. B149* (latest version), from Canadian Gas Association Laboratories, 55 Scarsdale Road, Don Mills, Ontario, Canada M3B 2R3. Also, *Canadian Electrical Code, C 22.1*, from Canadian Standards Association, 5060 Spectrum Way, Suite 100, Mississauga, Ontario, Canada L4W 5N6.

The latest version of the *National Electrical Code, NFPA No. 70*.

NOTE: The gas manifold and controls met safe lighting and other performance criteria when undergoing tests specified in *ANSI Z21.13* - latest edition.

! DANGER

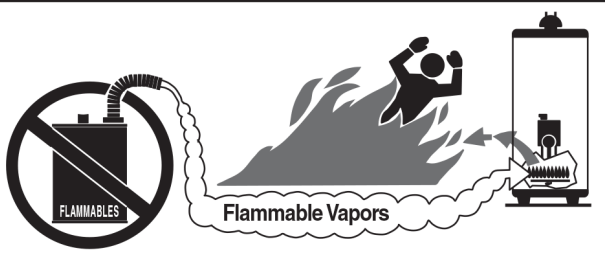

! Vapors from flammable liquids will explode and catch fire causing death or severe burns.
Do not use or store flammable products such as gasoline, solvents or adhesives in the same room or area near the water heater.
Keep flammable products:
1. far away from heater,
2. in approved containers,
3. tightly closed and
4. out of children's reach.

Installation:
Do not install water heater where flammable products will be stored or used unless the main burner and pilot flames

Water heater has a main burner and pilot flame.
The pilot flame:
1. which can come on at any time and
2. will ignite flammable vapors.
Vapors:
1. cannot be seen,
2. are heavier than air,
3. go a long way on the floor and
4. can be carried from other rooms to the pilot flame by air currents.

are at least 18" above the floor. This will reduce, but not eliminate, the risk of vapors being ignited by the main burner or pilot flame.

Read and follow water heater warnings and instructions. If owners manual is missing, contact the retailer or manufacturer.

! DANGER



Water temperature over 125°F can cause severe burns instantly or death from scalds. Children, disabled and elderly are at highest risk of being scalded. See instruction manual before setting temperature at water heater. Feel water before bathing or showering. Temperature limiting valves are available, see manual.

NOTICE

The CSD-1 ASME Code, Section CW-400 requires that hot water heating and supply boilers have a) a UL 353 temperature control device, b) at least one (1) temperature-actuated control to shut off the fuel supply when system water reaches a preset operating temperature, c) a high temperature limit control that prevents the water temperature from exceeding the maximum allowable temperature by causing a safety shutdown and lockout, and d) its own sensing element and operating switch.

The temperature control system integrated into the 926 control provided with this heating appliance complies with the requirements of CSD-1 Section CW-400 as a temperature operation control. The control monitors the temperature difference between the inlet and the outlet sensor, which is affected by boiler water flow. If this temperature difference exceeds 55°F (typically because of low water flow or very low heat load), the control will reduce the maximum fan speed. If the temperature difference exceeds 60°F, the control will effectively sense there is little or no water flow or heat load and shut the boiler down. The controller will restart automatically once the temperature difference has dropped below 55°F and the minimum off time (anti-cycle time) has expired. In addition, if the control senses that the outlet water temperature has reached 210°F, the boiler is put into a hard lockout and requires manual reset to restart.

Table of Contents

Part 1 - General Safety Information	5		
A. Improper Combustion	5	E. Exhaust Vent and Intake Pipe Sizing	26
B. Gas	5	F. Longer Vent Runs	26
C. When Servicing the Water Heating System	5	G. Exhaust Vent and Intake Pipe Installation	26
D. Boiler Water	5	H. Applications	27
E. Freeze Protection	5	1. Direct Vent Installation of Exhaust and Intake	27
F. High Elevation Installations	6	2. Room and Indoor Combustion Ventilation Requirements	30
G. Water Temperature Adjustment	6	Part 6 - Condensate Removal	31
Part 2 - Before You Start	7	Part 7 - Wiring	32
A. What's in the Box	8	A. Installation Must Comply With	32
B. How the Boiler Operates	8	B. Field Wiring Terminations	32
C. Optional Equipment	8	C. Field Wiring	32
Part 3 - Prepare the Boiler	8	D. Line Voltage Wiring for Standard Boiler	33
A. Locating the Boiler	9	E. Alarm Connections	33
B. Flooring	10	F. Low Voltage Connections for Standard Boiler	33
C. Leveling	10	G. Tank Sensor or Mechanical Control	33
D. Clearances for Service Access	10	H. System / Pipe Sensor	34
E. Residential Garage and Closet Installations	10	I. Optional 0-10 Volt Building Control Signal	34
F. Exhaust Vent and Intake Pipe	11	J. Optional High Gas Pressure Switch	34
1. Direct Vent of Exhaust and Intake	11	K. Optional Low Gas Pressure Switch	34
2. Indoor Combustion Air in Confined or Unconfined Space	11	L. Flow Switch	34
G. Carbon Monoxide Detectors	11	M. Wiring of Cascade System Communication Bus	34
H. Prevent Combustion Air Contamination	12	N. Cascade Master Pump and Sensor Wiring	34
I. Removing a Boiler from a Common Vent System	12	O. Cascade Follower Pump and Sensor Wiring	34
J. Water Chemistry Requirements*	12	Part 8 - Gas Connections	37
K. Technical Specifications	14	A. Gas Piping	38
Part 4 - Piping	16	B. Gas Table	38
A. General Plumbing Information	16	C. Check Inlet Gas Pressure	39
B. Relief Valve	16	D. Boiler Gas Valve	40
C. Backflow Preventer	16	Part 9 - Start-Up Preparation	41
D. Potable Expansion Tank	16	A. Check / Control Water Chemistry	41
E. Circulators	17	B. Check for Gas Leaks	41
F. Scalding	17	C. Condensate Removal	41
G. High Velocity Circulator Pump	17	D. Final Checks Before Starting Boiler	41
H. Water Chemistry	19	E. Setting Up a Single Boiler	41
I. Applications	20	F. Setting Up a Cascaded System	42
Part 5 - Venting	23	G. Lockout Condition	42
A. General	23	H. Cascade System Programming	42
B. Approved Materials for Exhaust Vent and Intake Pipe	24	Part 10 - Start-Up Procedure	43
C. Additional Requirements for Installation in Canada	24	A. Control Overview	43
D. Exhaust Vent and Intake Pipe Location	25	B. Navigation of the Display	43
		C. Operating Instructions	43
		D. Programming Boiler Settings	43
		E. Programming the System Setting	44
		F. System Setting Program Navigation	44
		G. Resetting the Maintenance Schedule	46
		Part 11 - Start-Up Procedures for the Installer	46
		A. Boiler Control Status Menu	46
		B. Cascade Menu	48
		C. Boiler Test Mode	49
		Part 12 - Troubleshooting	49
		A. Boiler Error and Fault Codes	49
		B. Boiler Error	49
		C. Boiler Fault	49
		D. User Interface Display	50
		Part 13 - Maintenance	55
		A. Procedures	55
		B. Combustion Chamber Coil Cleaning Instructions	55
		C. Cleaning Water Side of Heat Exchanger	56
		Part 14 - Installation Checklist	57
		Part 15 - Maintenance Report	57
		Part 16 - Replacement Parts	59
		Limited Warranty	63
		Maintenance Notes	65
		Customer Installation Record Form	66

Part 1 - General Safety Information

This boiler is approved for indoor installations only and is not intended for use as a pool heater. Clearance to combustible materials: 0" top, bottom, sides, and back. Left side has all boiler mechanical connections. Boiler must have room for service: 24" front is minimum recommended service clearance. (A combustible door or removable panel is acceptable front clearance.) This boiler has been approved for closet installation and installation on combustible flooring. Do not install directly on carpeting. Install the boiler in a location where temperature and pressure relief valve discharge or a leak will not result in damage to the surrounding area. If such a location is not available, install the boiler in a drain pan. Use only Category IV vent systems.

 WARNING
<p>Installer - Read all instructions in this manual before installing. Perform steps in the given order.</p> <p>User - This manual is for use only by a qualified heating installer / service technician. Have this boiler serviced / inspected annually by a qualified service technician.</p> <p>FAILURE TO ADHERE TO THE GUIDELINES ON THIS PAGE CAN RESULT IN SUBSTANTIAL PROPERTY DAMAGE, SEVERE PERSONAL INJURY, OR DEATH.</p> <p>NOTE: If the boiler is exposed to the following, do not operate. Immediately call a qualified service technician.</p> <ol style="list-style-type: none"> 1. Fire 2. Damage 3. Water <p>Failure to follow this information could result in property damage, severe personal injury, or death.</p> <p>DO NOT USE THIS BOILER IF ANY PART HAS BEEN SUBMERGED IN WATER. Immediately call a qualified service technician. The boiler MUST BE replaced if it has been submerged. Attempting to operate a boiler that has been submerged could create numerous harmful conditions, such as a potential gas leakage causing a fire and/or explosion, or the release of mold, bacteria, or other harmful particulates into the air. Operating a previously submerged boiler could result in property damage, severe personal injury, or death.</p> <p>NOTE: Boiler damage due to flood or submersion is considered an Act of God, and IS NOT covered under product warranty.</p> <p>NOTE: Obey all local codes. Obtain all applicable permits before installing the boiler.</p> <p>NOTE: Install all system components and piping in such a manner that does not reduce the performance of any fire rated assembly.</p> <p>This boiler has been designed to heat potable water ONLY. Using this boiler to heat non-potable fluid WILL VOID product warranty, and could result in property damage, personal injury, or death.</p> <p>Altering any HTP boiler with parts not manufactured by HTP. WILL INSTANTLY VOID the boiler warranty and could result in property damage, personal injury, or death.</p>
CAUTION
<p>Do not use this boiler for anything other than its intended purpose (as described in this manual). Doing so could result in property damage and WILL VOID product warranty.</p> <p>Due to low water content of the boiler, improperly sizing the boiler in regard to potable water heating load will result in excessive boiler cycling and accelerated component failure. HTP DOES NOT warrant failures caused by improperly sized boiler applications. DO NOT oversize the boiler to the system. Modular boiler installations greatly reduce the likelihood of boiler oversizing.</p>

CAUTION
<p>High heat sources (sources generating heat 100°F / 37°C or greater, such as stove pipes, space heaters, etc.) may damage plastic components of the boiler as well as plastic vent pipe materials. Such damages ARE NOT covered by warranty. It is recommended to keep a minimum clearance of 8" from high heat sources. Observe heat source manufacturer instructions, as well as local, state, provincial, and national codes, laws, regulations and ordinances when installing this boiler and related components near high heat sources.</p>

A. Improper Combustion

 WARNING
<p>Do not obstruct the flow of combustion and ventilating air. Adequate air is necessary for safe operation. Failure to keep the exhaust vent and combustion air intake clear of ice, snow, or other debris could result in property damage, serious personal injury, or death.</p>

B. Gas

Should overheating or gas supply fail to shut off, turn off the manual gas control valve to the boiler.

C. When Servicing the Water Heating System

 WARNING
<p>Be sure to disconnect electrical power before opening boiler cabinet or performing service. Failure to do so could result in electrical shock, property damage, serious personal injury, or death.</p>

To avoid electric shock, disconnect electrical supply before performing maintenance.

NOTE: When inquiring about service or troubleshooting, reference the model and serial numbers from the boiler rating label.

To avoid severe burns, allow boiler and associated equipment to cool before servicing.

D. Boiler Water

Do not use petroleum-based cleaning or sealing compounds in a water heating system. Gaskets and seals in the system may be damaged. This can result in substantial property damage.

Do not use "homemade cures" or "patent medicines". Damage to the boiler, substantial property damage, and/or serious personal injury may result.

E. Freeze Protection

NOTE: Consider piping and installation when determining boiler location.

CAUTION
<p>Failure of the boiler due to freeze related damage IS NOT covered by product warranty.</p>

 WARNING
<p>NEVER use any toxic chemical, including automotive, standard glycol antifreeze, or ethylene glycol made for hydronic (non-potable) systems. These chemicals can attack gaskets and seals in water systems, are poisonous if consumed, and can cause personal injury or death.</p>

NOTICE
<p>UNCRATING THE BOILER - Any claims for damage or shortage in shipment must be filed immediately against the transportation company by the consignee.</p>

F. High Elevation Installations

WARNING

Natural gas at high elevation might contain less heating value than typical 1,000 BTU/cu ft and therefore can cause improper air / gas mix leading to improper combustion. For natural gas installations above 3,000 ft, call your gas provider to determine the heating value of the supplied natural gas.

G. Water Temperature Adjustment

If the boiler is going to have a set temperature above 120°F, you must use an ASSE 1017 rated mixing valve to avoid severe burns or death from scalding temperatures.

WARNING

Households with small children, disabled, or elderly persons may require a 120°F or lower temperature setting to prevent severe personal injury or death due to scalding.

Approximate Time / Temperature Relationships in Scalds

120°F	More than 5 minutes
125°F	1 1/2 to 2 minutes
130°F	About 30 seconds
135°F	About 10 seconds
140°F	Less than 5 seconds
145°F	Less than 3 seconds
150°F	About 1 1/2 seconds
155°F	About 1 second

Table 1 - Approximate Time / Temperature Relationships in Scalds

Part 2 - Before You Start

CAUTION

VWH units must be connected to a storage tank. You must not have a direct connection of the potable water system into the heat exchanger. This could cause flow issues, short cycling, and an increase of mineral build-up in the unit. This system is designed to have incoming potable water flow through the storage tank first, then through the heat exchanger. Failure to connect the VWH boiler to a storage tank of the minimum size requirements (119 gallons for a single 500VWH; 175 gallons for a single 700/850VWH) will result in property damage and/or premature boiler failure. Damages resulting from incorrect installation or from use of products not approved by HTP ARE NOT covered by warranty.

ΔT (Delta T) (°F)	500VWH				700VWH			850VWH			
	Gallons Per Hour	Storage Tanks (Gallons)*			Gallons Per Hour	Storage Tanks (Gallons)*		Gallons Per Hour	Storage Tanks (Gallons)*		
		119	175	200		175	200		175	200	300
		First Hour Rating				First Hour Rating			First Hour Rating		
40°	1474	1563	1605	1624	2064	2195	2214	2480	2570	2612	2630
50°	1179	1269	1311	1329	1651	1782	1801	1984	2074	2116	2134
60°	983	1072	1114	1133	1376	1507	1526	1654	1743	1785	1804
70°	842	932	974	992	1179	1311	1329	1417	1507	1549	1567
80°	737	826	868	887	1032	1163	1182	1240	1329	1371	1390
90°	655	744	786	805	917	1048	1067	1102	1192	1234	1252
100°	590	679	721	740	826	957	976	992	1081	1123	1142
110°	536	625	667	686	750	882	900	902	991	1033	1052
120°	491	581	623	641	688	819	838	827	916	958	977
130°	454	543	585	604	635	766	785	763	852	894	913
140°	421	510	552	571	590	721	740	709	798	840	859

*Contact HTP for Available Storage Tanks

Table 2 - VWH Ratings with Storage Tanks - NOTE: Gallons Per Hour Does Not Take a Storage Tank into Account

NOTE: First Hour Rating can be increased by using an external mixing valve and increasing tank setpoint temperature. Example: If installation requires 120°F from mixing valve, set the tank at 140°F to increase First Hour Rating.

$$\text{First Hour Rating (FHR)} = \frac{\text{Total Input Rate} \times \text{Thermal Efficiency}}{(\text{VWH Outlet Temp} - \text{Inlet Temp}) \times 8.31} + .75 \times \text{Total Storage}$$

Example:

- 2 500VWH Boilers = Total Output = 1,000,000 BTU
- Thermal Efficiency = 98% Efficiency
- VWH Outlet Temp = 140°F - Inlet Temp = 40°F
- 2 Storage Tanks (119 Gallons Each) = 238 Gallons Total Storage

$$\text{FHR} = \frac{1,000,000 \times .98}{(140 - 40) \times 8.31} + .75 \times 238$$

$$\text{FHR} = \frac{980,000}{831} + 179$$

$$\text{FHR} = 1,179 + 179$$

$$\text{FHR} = 1,358 \text{ Gallons}$$

Peak Hour Demand / First Hour Rating*				
Use	Average Gallons of Hot Water Per Usage		Times Used During One Hour	Gallons Used in One Hour
Shower	20	X	1	20
Bath	20		1	20
Shavings	2		1	2
Hands and Face Washing	4		1	4
Hair Shampoo	4		1	4
Hand Dishwashing	4		1	4
Automatic Dishwasher	14		1	14
Food Preparation	5		1	5
Wringer Clothes Washer	26		1	26
Automatic Clothes Washer	32		1	32
Total Peak Hour Demand (FHR)				131

Table 3 - Peak Hour Demand / First Hour Rating - NOTE: The above table assumes no water conservation measures. - *For Reference Use ONLY.

A. What's in the Box

Remove all sides of the shipping crate of the boiler.

Components included with the boiler:

- Temperature and Pressure Gauge
- Pressure Relief Valve
- Three (3) Stainless Steel Screens
- Supply and Return Thermistors
- Wiring Harness
- Flow Switch and Fitting
- System/Pipe Sensor
- Installation Manual and Warranty
- User's Information Manual
- CSD-1 Form
- H-3 Data Sheet

B. How the Boiler Operates

VWH® condensing technology intelligently delivers large amounts of hot water while maximizing efficiency. Outlined below are the features of the system and how they operate:

Stainless Steel Heat Exchanger

The highly efficient stainless steel heat exchanger is designed to use the cold water return from the storage tank and extract the last bit of heat before it is exhausted.

Modulating Combustion System

The combustion system modulates the output of the burner during operation to match system demand and achieve the control set point while in operation. The set point can change by internal or external signals to enhance the overall performance of the system.

Control

The integrated control system monitors the system and regulates fan speed to control boiler output. This allows the boiler to deliver only the amount of heat energy required and nothing more.

The control can regulate the output of multiple boilers through its cascade system function. The cascade system is capable of connecting up to eight boilers together in such a way that they function as one boiler system. This allows for greater turn down ratios and provides systematic control of the multiple boilers in an installation to minimize downtime and maximize efficiency.

The cascade system works by establishing one boiler as the master and the other connected boilers as followers. The master boiler requires a sensor to provide feedback on set point temperature in order to adjust heating input from the connected boilers. Each cascaded boiler will have its own pump to provide maximum flow and control heat exchanger flow rate.

Text Display and Operational LED Light Indicators

The display allows the user to change system parameters and monitor system outputs.

Gas Valve

Senses suction from the blower, allowing gas to flow only if powered and combustion air is flowing.

Integrated Venturi (500 Models) or Swirl Plate (700/850 Models)

Controls air and gas flow into the burner.

Burner

The high grade stainless steel burner uses premixed air and gas to provide a wide range of firing rates.

Spark Ignition

The burner is ignited by applying high voltage through the system spark electrode. The spark from the electrode ignites mixed gas off of the burner.

Supply Water Temperature Sensor

This sensor monitors the boiler outlet water temperature (System Supply). The control adjusts boiler firing rate so the supply temperature will match the boiler set point.

Return Water Temperature Sensor

This sensor monitors boiler return water temperature (System Return).

Temperature and Pressure Gauge

Allows the user to monitor system temperature and pressure.

Electrical field connections with terminal strips

The electrical cover allows easy access to the clearly marked line voltage and low voltage terminal strips to facilitate wiring the boiler.

Condensate Collection System

This boiler is a high efficiency appliance and will produce condensate. The condensate collection system has a float switch which monitors condensate level and prevents condensate from backing up into the combustion system. Inside the collection system is a built in trap which seals the combustion system from the connected drain. This condensate should be neutralized to avoid damage to the drainage system or piping.

Flow Protection

The supplied flow switch is designed to protect the boiler during low flow conditions. The boiler control also monitors flow through the heat exchanger by monitoring the return and supply sensors and will shut down the burner before overheating occurs.

System Pipe Sensor

This sensor is designed to be used in a cascade system. When placed on the supply line feeding the storage tank, the system pipe sensor measures the temperature of return water and communicates with the control system to modulate the firing rate of the connected boilers.

NOTE: When using a system sensor, pipe insulation must be wrapped around it to improve temperature measurement accuracy and increase overall system efficiency.

0-10 Volt Input

Allows the installer to connect a BMS (Building Management System) to control the boiler.

Indirect Tank Sensor (optional)

Monitors storage tank temperature.

C. Optional Equipment

Optional equipment available from HTP (and Part #):

- Indirect Tank Sensor (7250P-325)
- 4" Stainless Steel Vent Termination Kit (V2000)
- 6" Stainless Steel Vent Termination Kit (V3000)
- High and Low Gas Pressure Switch Kit with Manual Reset (7350P-600)
- UL 353 Compliant Low Water Cut-Off Interface Kit with Manual Reset (7350P-601)
- Alarm System (to monitor any failure) (7350P-602)
- PC Connection Kit (7250P-320)
- Condensate Neutralizer (7350P-611)
- Caster Kit (7350P-604)
- Glass-Lined Storage Tanks (GL-119, GL-175)
- Stainless Steel Storage Tank (SSU-119CB)

Part 3 - Prepare the Boiler

Remove all sides of the shipping crate to allow the boiler to be moved into its installation location. Pick the boiler up by the lifting rings to avoid damage to the boiler enclosure. Use either solid 3/4" diameter black iron pipe or lifting straps to lift the boiler off its shipping crate. The boiler is heavy. At least two individuals are needed to properly handle the boiler. The boiler is also equipped with leveling feet that can be used to level the boiler properly on an uneven location surface. If surface flooring is rough, take care when moving the boiler into position, as catching the leveling feet could damage the boiler.

CAUTION

COLD WEATHER HANDLING - If the boiler has been stored in a very cold location (BELOW 0°F) before installation, handle with care until the components come to room temperature. Failure to do so could result in damage to the boiler.

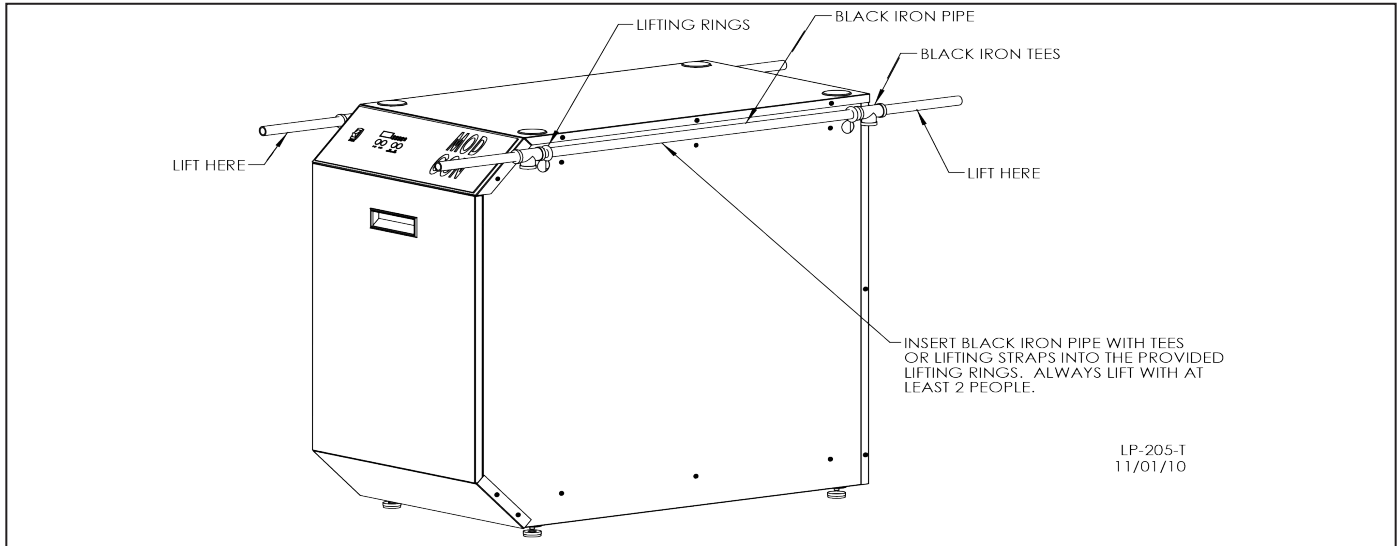

Figure 1 - Lifting the Boiler

CAUTION

Carefully consider installation when determining boiler location. Please read the entire manual before attempting installation. Failure to properly take factors such as boiler venting, piping, condensate removal, and wiring into account before installation could result in wasted time, money, and possible property damage and personal injury.

A. Locating the Boiler

WARNING

This boiler is certified for indoor use only. DO NOT INSTALL OUTDOORS. Outdoor installations ARE NOT covered by warranty. Failure to install the boiler indoors could result in property damage, severe personal injury, or death.

Incorrect ambient conditions can lead to damage to the heating system and put safe operation at risk. Ensure that the installation location adheres to the information included in this manual. Failure to do so could result in property damage, serious personal injury, or death. Failure of boiler or components due to incorrect operating conditions IS NOT covered by product warranty.

1. Installation Area (Mechanical Room) Operating Conditions

- Ensure ambient temperatures are higher than 32°F / 0°C and lower than 104°F / 40°C
- Prevent the air from becoming contaminated by the products, places, and conditions listed in this manual
- Avoid continuously high levels of humidity
- Never close existing ventilation openings
- Ensure a minimum 1" clearance around hot water and exhaust vent pipes
- NOTE: To prevent condensing in the fan, it is recommended to avoid prolonged exposure to temperatures below 45°F

WARNING

This boiler has a condensate disposal system that may freeze if exposed to sustained temperatures below 32°F. Precautions should be taken to protect the condensate trap and drain lines from sustained freezing conditions. Failure to take precautions could result in property damage, severe personal injury, or death.

2. Check for nearby connections to:

- System water piping

- Venting connections
- Gas supply piping
- Electrical power
- Condensate drain

3. Check area around boiler. Remove any combustible materials, gasoline, and other flammable liquids.

WARNING

Failure to keep the boiler area clear and free of combustible materials, liquids, and vapors can result in substantial property damage, severe personal injury, or death.

CAUTION

The service life of the boiler's exposed metallic surfaces, such as the casing, as well as internal surfaces, such as the heat exchanger, are directly influenced by proximity to damp and salty marine environments. In such areas higher concentration levels of chlorides from sea spray coupled with relative humidity can lead to degradation of boiler components. In these environments, boilers must not be installed using direct vent systems which draw outdoor air for combustion. Such boilers must be installed using room air for combustion. Indoor air will have a much lower relative humidity, and hence potential corrosion will be minimized.

High heat sources (generating heat 100°F / 37°C or greater, such as boiler flue pipes, space heaters, etc.) may damage plastic components of the boiler as well as plastic vent pipe materials. Such damages ARE NOT covered by warranty. It is recommended to keep a minimum clearance of 8" from high heat sources. Observe heat source manufacturer instructions, as well as local, state, provincial, and national codes, laws, regulations, and ordinances when installing this boiler and related components near high heat sources.

Failure of the boiler or components due to incorrect operating conditions IS NOT covered by product warranty.

4. Gas control system components must be protected from dripping water during operation and service.

5. If the boiler is to replace an existing boiler, check for and correct any existing system problems, such as:

- System leaks
- Location that could cause the system and boiler to freeze and leak
- Incorrectly sized expansion tank

6. Clean and flush system when reinstalling a boiler.

NOTE: When installing in a zero clearance location, it may not be

possible to read or view some product labeling. It is recommended to make note of the boiler model and serial number.

WARNING
Use extreme care not to drop the boiler or cause bodily injury while lifting the boiler.
Gas conversion should be performed BEFORE the boiler is installed. Carefully follow the gas conversion instructions when performing the conversion.
Failure to follow these instructions could result in property damage, severe personal injury, or death.

B. Flooring

WARNING
This boiler is approved for installation on combustible flooring, but must never be installed on carpeting. Installing this boiler on carpeting could result in fire, property damage, severe personal injury, or death.
Assure that the floor and structure of the installation location are sufficient to support the full installed weight of the boiler, including water content of the heat exchanger and related piping. Failure to ensure the floor and structure of the installation location are structurally sound before installation of the boiler can result in structural failure, substantial property damage, severe personal injury, or death.

C. Leveling

CAUTION
In order for the condensate to properly flow out of the collection system, the area where you locate the boiler must be level. Location must also fully support the weight of the filled boiler.

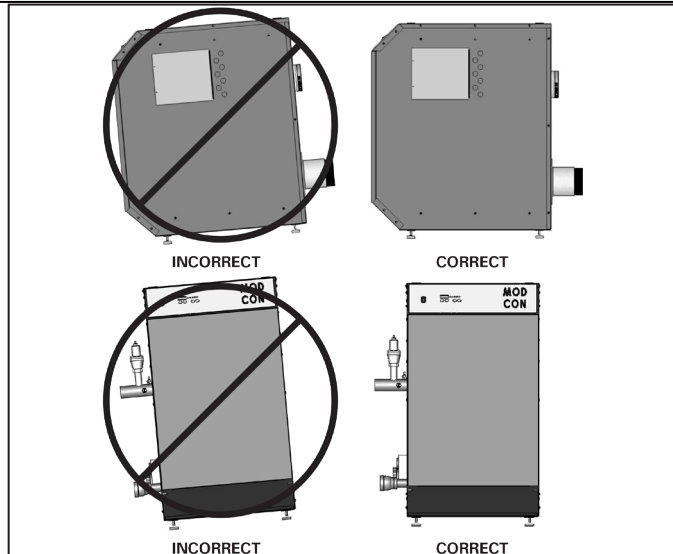

Figure 2 - Correct and Incorrect Leveling

D. Clearances for Service Access

NOTE: If you do not provide the minimum clearances shown in Figure 3 it might not be possible to service the boiler without removing it from the space.

NOTE: A combustible door or removable panel is acceptable front clearance.

WARNING
The space must be provided with combustion / ventilation air openings correctly sized for all other appliances located in the same space as the boiler. The boiler cover must be securely fastened to prevent the boiler from drawing air from the boiler room. This is particularly important if the boiler is in a room with other appliances. Failure to comply with the above warnings could result in substantial property damage, severe personal injury, or death.
This boiler must be installed upright in the vertical position as described in this manual. DO NOT attempt to install this boiler in any other orientation. Doing so will result in improper boiler operation and property damage, and could result in serious personal injury or death.
CAUTION
All boilers eventually leak. Locate the boiler where any leakage from the relief valve, related piping, tank, or connections will not result in damage to surrounding areas or lower floors of the building. Any boiler should be installed in such a manner that if it should leak the resulting flow of water will not cause damage to the area in which it is installed. If the boiler is installed in a location where a leak could cause damage, it is required to provide containment measures. Such measures include but are not limited to: a properly sized drain pan installed beneath the boiler and piped to an open drain line, or installing the boiler on a concrete floor pitched to a free flowing drain. Failure to provide containment measures is the sole responsibility of the owner and/or installer. Leakage damages ARE NOT covered by warranty. In addition, water leak detection devices and automatic water shutoff valves are readily available at plumbing supply houses. IT IS HIGHLY RECOMMENDED BY THE MANUFACTURER TO INSTALL WATER LEAK DETECTION DEVICES AND AUTOMATIC SHUTOFF VALVES IN ANY BOILER INSTALLATION WHERE A LEAKAGE OF WATER COULD RESULT IN PROPERTY DAMAGES.

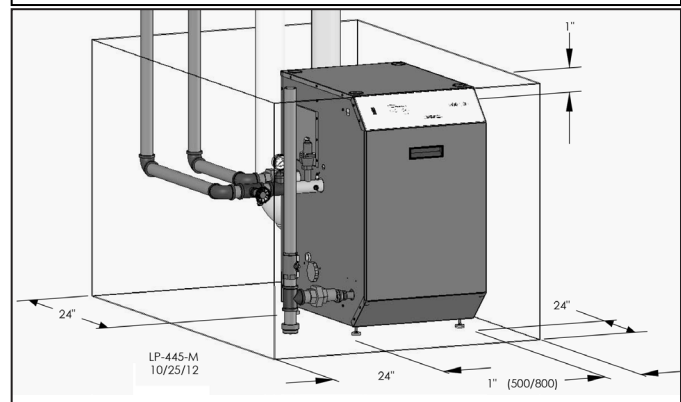

Figure 3 - Recommended Service Clearances

E. Residential Garage and Closet Installations

CAUTION
Check with your local Authority Having Jurisdiction for requirements when installing the boiler in a garage or closet. Please read the entire manual before attempting installation. Failure to properly take factors such as venting, piping, condensate removal, and wiring into account before installation could result in wasted time, money, and possible property damage and personal injury.

Precautions

If the boiler is located in a residential garage, per ANSI Z223.1:

- Install the boiler burner and ignition devices a minimum of 18" above the floor of the garage. This will ensure the burner

- and ignition devices are well off the floor.
- When raising the boiler ensure the entire bottom and fully filled weight of the boiler are fully supported.
- Locate or protect the boiler so it cannot be damaged by a moving vehicle.

WARNING

The space must be provided with correctly sized combustion/ventilation air openings for all other appliances located in the space with the boiler. For power venting installations using room air for combustion, refer to the venting section, this manual, for descriptions of confined and unconfined spaces. Do not install the boiler in an attic. Failure to comply with these warnings could result in substantial property damage, severe personal injury, or death.

F. Exhaust Vent and Intake Pipe

The boiler is rated ANSI Z21.13 Category IV (pressurized vent, likely to form condensate in the vent) and requires a special vent system designed for pressurized venting.

NOTE: The venting options described here (and further detailed in the Venting section, this manual) are the lone venting options approved for this boiler. Failure to vent the boiler in accordance with the provided venting instructions will void the warranty.

DANGER

Failure to vent the boiler properly will result in serious personal injury or death.

WARNING

Do not attempt to vent this boiler by any means other than those described in this manual. Doing so will void the warranty and may result in severe personal injury or death.

Vents must be properly supported. Boiler exhaust and intake connections are not designed to carry heavy weight. Vent support brackets must be within 1’ of the boiler and the balance at 4’ intervals. Boiler must be readily accessible for visual inspection for first 3’ from the boiler. Failure to properly support vents could result in property damage, severe personal injury, or death.

The exhaust discharged by this boiler may be very hot. Avoid touching or other direct contact with the exhaust gases of the vent termination assembly. Doing so could result in severe personal injury or death.

1. Direct Vent of Exhaust and Intake

If installing a direct vent option, combustion air must be drawn from the outdoors directly into the boiler intake and exhaust must terminate outdoors. There are three basic direct vent options detailed in this manual: 1. Side Wall Venting, 2. Roof Venting, and 3. Unbalanced Venting.

Be sure to locate the boiler such that the exhaust vent and intake piping can be routed through the building and properly terminated. Different vent terminals can be used to simplify and eliminate multiple penetrations in the building structure (see Optional Equipment in Venting Section). The exhaust vent and intake piping lengths, routing, and termination methods must all comply with the methods and limits given in the Venting Section, this manual.

When installing a combustion air intake from outdoors, care must be taken to utilize uncontaminated combustion air. **To prevent combustion air contamination, see Table 4.**

2. Indoor Combustion Air in Confined or Unconfined Space

This boiler requires fresh, uncontaminated air for safe operation and must be installed in a mechanical room where there is adequate combustion and ventilating air. **NOTE: To prevent combustion air contamination, see Table 4.**

Combustion air from the indoor space can be used if the space has adequate area or when air is provided through a duct or louver

to supply sufficient combustion air based on the boiler input. Never obstruct the supply of combustion air to the boiler. If the boiler is installed in areas where indoor air is contaminated (see Table 4) it is imperative that the boiler be installed as direct vent so that all combustion air is taken directly from the outdoors into the boiler intake connection.

Unconfined space is space with volume greater than 50 cubic feet per 1,000 BTU/hr (4.8 cubic meters per kW) of the total input rating of all fuel-burning appliances installed in that space. Rooms connected directly to this space through openings not furnished with doors are considered part of the space. See Venting Section for details.

Confined space is space with volume less than 50 cubic feet per 1,000 BTU/hr (4.8 cubic meters per kW) of the total input rating of all fuel-burning appliances installed in that space. Rooms connected directly to this space through openings not furnished with doors are considered part of the space.

When drawing combustion air from inside a conventionally constructed building to a confined space, such space should be provided with two permanent openings: one located 6” (15 cm) below the space ceiling, the other 6” (15cm) above the space floor. Each opening should have a free area of one square inch per 1,000 BTU/hr (22cm²/kW) of the total input of all appliances in the space, but not less than 100 square inches (645cm²).

If the confined space is within a building of tight construction, air for combustion must be obtained from the outdoors as outlined in the Venting section of this manual.

CAUTION

When drawing combustion air from the outside into the mechanical room, care must be taken to provide adequate freeze protection.

WARNING

Failure to provide an adequate supply of fresh combustion air can cause poisonous flue gases to enter the living space, resulting in severe personal injury or death. To prevent combustion air contamination, see Table 4.

G. Carbon Monoxide Detectors In the Commonwealth of Massachusetts and As Required by State and Local Codes:

Installation of Carbon Monoxide Detectors: At the time of installation or replacement of the vented gas fueled appliance, the installing plumber or gas fitter shall observe that a hard wired carbon monoxide detector with an alarm and battery back-up is installed on the floor level where the gas appliance is installed, unless the appliance is located in a detached, uninhabitable structure separate from the dwelling, building, or structure used in whole or in part for residential purposes.

In addition, the installing plumber or gas fitter shall observe that a hard wired carbon monoxide detector with an alarm and battery back-up is installed on each additional level of the dwelling, building, or structure served by the vented gas appliance. It shall be the responsibility of the property owner to secure the service of qualified licensed professionals for the installation of hard wired carbon monoxide detectors.

- a. In the event that the vented gas fueled appliance is installed in a crawl space or attic, the hard wired carbon monoxide detector with alarm and battery back-up shall be installed on the next adjacent floor level.
- b. In the event that these requirements cannot be met at the time of completion of installation, the owner shall have a period of thirty (30) days to comply with the above requirements; provided, however, that during said thirty (30) day period, a battery operated carbon monoxide detector with an alarm shall be installed.

WARNING

Do not attempt to vent this appliance by any means other than those described in this manual. Doing so will void the warranty and may result in severe personal injury or death.

Approved Carbon Monoxide Detectors: Each carbon monoxide detector as required in accordance with the above provisions shall comply with NFPA 70 and be ANSI/UL 2034 listed and IAS certified.

H. Prevent Combustion Air Contamination

Install intake air piping for the boiler as described in the Venting Section, this manual. Do not terminate exhaust in locations that can allow contamination of intake air.

WARNING

Ensure that the intake air will not contain any of the contaminants in Table 4. Contaminated air will damage the boiler, resulting in possible substantial property damage, severe personal injury, or death. For example, do not pipe intake air near a swimming pool or laundry facilities. These areas always contain contaminants.

Products to Avoid	Areas Likely to Have Contaminants
Spray cans containing fluorocarbons	Dry cleaning / laundry areas and establishments
Permanent wave solutions	Swimming pools
Chlorinated waxes / cleaners	Metal fabrication plants
Chlorine-based swimming pool chemicals	Beauty shops
Calcium chloride used for thawing	Refrigeration repair shops
Sodium chloride used for water softening	Photo processing plants
Refrigerant leaks	Auto body shops
Paint or varnish removers	Plastic manufacturing plants
Hydrochloric or Muriatic acid	Furniture refinishing areas and establishments
Cements and glues	New building construction
Antistatic fabric softeners used in clothes dryers	Remodeling areas
Chlorine-type bleaches, laundry detergents, and cleaning solvents	Garages and workshops
Adhesives used to fasten building products	

Table 4 - Products and Areas Likely to Have Contaminants

NOTE: DAMAGE TO THE BOILER CAUSED BY EXPOSURE TO CORROSIVE VAPORS IS NOT COVERED BY WARRANTY. (Refer to the limited warranty for complete terms and conditions.)

I. Removing a Boiler from a Common Vent System

DANGER

Do not install the boiler into a common vent with any other appliance. This will cause flue gas spillage or appliance malfunction, resulting in possible substantial property damage, severe personal injury, or death.

WARNING

Failure to follow all instructions can result in flue gas spillage and carbon monoxide emissions, causing severe personal injury or death.

When removing an existing boiler, follow the steps below.

1. Seal any unused openings in the common venting system.

2. Visually inspect the venting system for proper size and horizontal pitch to determine if there is blockage, leakage, corrosion, or other deficiencies that could cause an unsafe condition.
3. If practical, close all building doors, windows, and doors between the space in which the boiler remains connected to the common venting system and other spaces in the building. Turn on clothes dryers and any appliances not connected to the common venting system. Turn on any exhaust fans, such as range hoods and bathroom exhausts, at maximum speed. Do not operate a summer exhaust fan. Close all fireplace dampers.
4. Place in operation the appliance being inspected. Follow the lighting instructions. Adjust the thermostat so the appliance will operate continuously.
5. Test for spillage at the draft hood relief opening after 5 minutes of main burner operation. Use the flame of a match or candle or smoke from a cigarette.
6. After it has been determined that each appliance remaining connected to the common venting system properly vents when tested as outlined, return doors, windows, exhaust fans, fireplace dampers, and any other gas burning appliances to their previous condition of use.
7. Any improper operation of the common venting system should be corrected to conform to the National Fuel Gas Code, ANSI Z223.1. When resizing any portion of the common venting system, the system should approach the minimum size as determined using the appropriate tables in Appendix G of ANSI Z223.1.

WARNING

Breathing Hazard - Carbon Monoxide Gas



- Do not operate heater if flood damaged.
- Install vent system in accordance with local codes and manufacturers installation instructions.
- Do not obstruct heater air intake or exhaust. Support all vent piping per manufacturers installation instructions.
- Do not place chemical vapor emitting products near unit.
- According to NFPA 720, carbon monoxide detectors should be installed outside each sleeping area.
- Never operate the heater unless it is vented to the outdoors.
- Analyze the entire vent system to make sure that condensate will not become trapped in a section of vent pipe and therefore reduce the open cross sectional area of the vent.

Breathing carbon monoxide can cause brain damage or death. Always read and understand instruction manual.

LP-304

Figure 4 - CO Warning Label

J. Water Chemistry Requirements*

CAUTION

Chemical imbalance of the water supply may affect efficiency and cause severe damage to the appliance and associated equipment. Water quality must be professionally analyzed to determine whether it is necessary to treat the water. Various solutions are available to adjust water quality. Adverse water quality will affect the reliability of the system. In addition, operating temperatures above 135°F will accelerate the build-up of lime scale and possibly shorten appliance service life. Failure of an appliance due to lime scale build-up, low pH, or other chemical imbalance IS NOT covered by the warranty.

The water must be potable, free of corrosive chemicals, sand, dirt, and other contaminants. It is up to the installer to ensure the water does not contain corrosive chemicals or elements that can damage

the heat exchanger. Potable water is defined as drinkable water supplied from utility or well water in compliance with EPA secondary maximum contaminant levels (40 CFR Part 143.3) as shown in the table below. If the water contains contaminants higher than outlined by the EPA, water treatment is recommended and additional, more frequent maintenance may be required.

If you suspect that your water is contaminated in any way, discontinue use of the appliance and contact an authorized technician or licensed professional.

Contaminant	Maximum Allowable Level	Contaminant	Maximum Allowable Level
Total Hardness (Commercial Use - 140°F and above water temperature)	120 mg/l (7 grains/gallon)	pH	6.5-8.5
		Sulfate	205 mg/l
		Total Dissolved Solids (TDS)	500 mg/l
Aluminum	0.05 to 0.2 mg/l	Zinc	5 mg/l
Chloride	100 mg/l		
Copper	1 mg/l	Dissolved Carbon Dioxide (CO2)	15 mg/l or PPM
Iron	0.3 mg/l		
Manganese	0.05 mg/l		

Table 5 - Water Quality Specifications

***NOTE:** It is recommended to clean heat exchanger at least once a year to prevent lime scale buildup. Follow the maintenance procedure in the Maintenance Section of this manual to clean the heat exchanger.

K. Technical Specifications

Model		500	700	850
Installation		Indoor, Floor Standing, Fully Condensing		
Minimum / Maximum Input (Btu/Hr)		100,000 / 500,000	170,000 / 700,000	170,000 / 850,000
Heating Capacity (MBH)		470	686	799
Flue System		Category IV, Sealed Combustion Direct Vent, Power Vent		
Minimum Combined Vent Run		16 feet		
Maximum Combined Vent Run		4" (200 feet)	6" (200 feet)	
Approved Exhaust Vent Materials		PVC, CPVC, PP, Stainless Steel		
Shipping Weight (lbs)		505	580	
Gas Supply Pressure	NG	3.5" to 14" WC		
	LP			
Manifold Pressure	Min / Max	NG/LP: -0.01" WC		
Power Supply		120V 60 Hz, 6.3A		
General Operating Conditions		Ambient Temperature Range: 33 – 104°F (0.6 – 40°C) Product Approvals and Requirements: ANSI Z21.13 / CSA 4.9		
Ignition System		Direct Electronic Spark Ignition / Flame Rectification		
Burner System		Premixed Fuel Modulation / Stainless Steel Metal Fiber Burner		
Gas Valve System		Air Ratio Valve		
Dimensions (in Inches)	W	20.5		
	H	36		
	D	46	68.5	
Boiler Water Content (Gallons)		4.2	5.8	
Minimum Flow Rate @ 30°F ΔT (GPM)		33	54	
DHW Setpoint Temperature Range		95 – 180°F		
Water Pressure (PSI)	Heat Exchanger MAWP	160		
	Pressure Relief Valve	150		
Control Panel / Main Controller		LCD Display with LED Indicators / 926 SIT Control		
Connection Sizes	Supply / Return	2" NPT		
	Gas Inlet	1 1/2" NPTF	2" NPTF	
Materials	Cabinet	Powder Coated Galvaneal Steel		
	Heat Exchanger	316L Stainless Steel Water Tube		
Safety Devices		Flame Rectifier Probe, Water Temperature High Limit Switch (190°F), Freeze Protection, Condensate Trap with Overflow Switch, Included LWCO (Optional UL 353 LWCO), Blocked Vent Pressure Switch, Optional Gas High/Low Pressure Switch, Flow Switch		

Table 6 - Technical Specifications

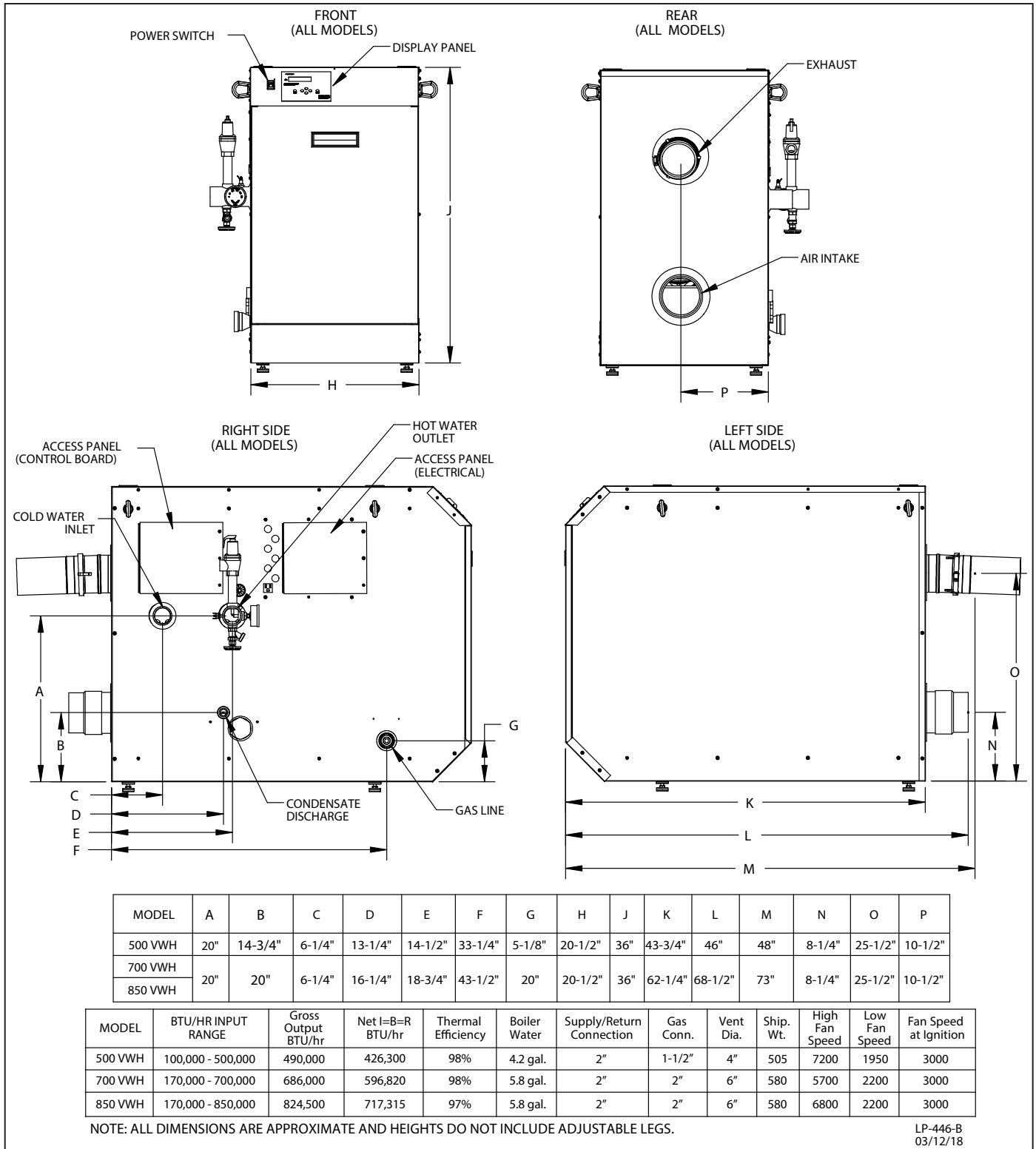

Figure 5 - Boiler Dimensions - NOTE: All Dimensions Are Approximate - VWH in Model Number Denotes Volume Water Heater Model

Part 4 - Piping

WARNING

Failure to follow the instructions in this section WILL VOID the warranty and may result in property damage, severe personal injury, or death.

CAUTION

Dielectric unions or galvanized steel fittings must not be used in a system with this boiler. Doing so WILL VOID the warranty. Use only copper, brass, or stainless steel fittings. Teflon thread sealant must be used on all connections.

DO NOT pipe this boiler with black iron, galvanized steel, steel, or lead pipe. Doing so will result in premature product failure and property damage, and WILL VOID the warranty.

Plumbing of this product should only be done by a qualified, licensed plumber in accordance with all local plumbing codes. The boiler is designed to be connected to a storage tank to supply domestic hot water. HTP offers 119 and 175 gallon size storage tanks in either stainless steel or glass-lined construction. These storage tanks will be directly connected to the boiler supply and return connection. Larger Storage Tanks are Available Upon Request. Contact HTP Customer Service for more information.

CAUTION

VWH units must be connected to a storage tank. Failure to connect the VWH boiler to a storage tank of the minimum size requirements (119 gallons for a single 500VWH; 175 gallons for a single 700/850VWH) will result in property damage and/or premature boiler failure. Damages resulting from incorrect installation or from use of products not approved by HTP ARE NOT covered by warranty.

A. General Plumbing Information

CAUTION

The building piping system must meet or exceed the the piping requirements in this manual.

The control module uses temperature sensors to provide both high limit protection and modulating temperature control. The control module also provides low water protection by sensing the water level in the heat exchanger. Some codes/jurisdictions may require additional external controls.

Use two wrenches when tightening water piping at boiler. Use one wrench to prevent the boiler return or supply line from turning. Failure to prevent piping connections from turning could cause damage to boiler components.

NOTE: The addition of a high temperature limiting device is important if the boiler is to be connected to a domestic hot water system. Connect the cold water supply to both the storage bottom port and the supply side of the boiler (shown in Applications, this manual). It is important that you install a flow check on the supply line of the boiler BEFORE connecting the feed line to the storage tank. This allows the cold feed to flow through the storage tank first. It is recommended that you install shut off valves on the cold feed line for future ease of service. If there is a back flow preventer or any type of no return valve in the system, then you must install an additional tee for a suitable potable hot water expansion tank. Connect the storage tank return line to the return connection located on the boiler (shown in Applications, this manual). Then connect the storage tank hot water outlet to the hot water plumbing lines.

B. Relief Valve

Connect discharge piping to a safe disposal location following the guidelines below.

WARNING

To avoid water damage or scalding due to relief valve operation:

- Discharge line must be connected to relief valve outlet and run to a safe place of disposal. Terminate the discharge line in a manner that will prevent possibility of severe burns or property damage should the relief valve discharge.
- Discharge line must be as short as possible and the same size as the valve discharge connection throughout its entire length.
- Discharge line must pitch downward from the valve and terminate at least 6" above the floor drain, making discharge clearly visible.
- The discharge line shall terminate plain, not threaded, with a material serviceable for temperatures of 375°F or greater.
- Do not pipe discharge to any location where freezing could occur.
- No valve may be installed between the relief valve and boiler or in the discharge line. Do not plug or place any obstruction in the discharge line.
- Test the operation of the relief valve after filling and pressurizing the system by lifting the lever. Make sure the valve discharges freely. If the valve fails to operate correctly, immediately replace with a new properly rated relief valve.
- Test T&P valve at least once annually to ensure the waterway is clear. If valve does not operate, turn the boiler "off" and call a plumber immediately.
- Take care whenever operating relief valve to avoid scalding injury or property damage.

FAILURE TO COMPLY WITH THE ABOVE GUIDELINES COULD RESULT IN FAILURE OF RELIEF VALVE OPERATION, RESULTING IN POSSIBILITY OF SUBSTANTIAL PROPERTY DAMAGE, SEVERE PERSONAL INJURY, OR DEATH.

Do not thread a cap or plug into the relief valve or relief valve line under any circumstances! Explosion and property damage, serious injury, or death may result.

RE-INSPECTION OF T&P RELIEF VALVES: T&P valves should be inspected AT LEAST ONCE EVERY THREE YEARS, and replaced if necessary, by a licensed plumbing contractor or qualified service technician to ensure that the product has not been affected by corrosive water conditions and to ensure that the valve and discharge line have not been altered or tampered with illegally. Certain naturally occurring conditions may corrode the valve and its components over time, rendering the valve inoperative. Such conditions can only be detected if the valve and its components are physically removed and inspected. **Do not attempt to conduct an inspection on your own.** Contact your plumbing contractor for a re-inspection to assure continued safety.

FAILURE TO RE-INSPECT THE T&P VALVE AS DIRECTED COULD RESULT IN UNSAFE TEMPERATURE AND/OR PRESSURE BUILD-UP WHICH CAN RESULT IN PROPERTY DAMAGE, SERIOUS PERSONAL INJURY, OR DEATH.

C. Backflow Preventer

Use a backflow preventer specifically designed for boiler installations. This valve should be installed on the cold water fill supply line per local codes.

D. Potable Expansion Tank

A potable hot water expansion tank is required to offset heated water expansion. In most city plumbing systems, the water meter has a no return or back flow device built into the system to prevent back flowing of water into city mains. Some local codes require

back flow preventers on all incoming water supplies. The hot water expansion tank must be listed for potable water use. The expansion tank should be located on the cold inlet piping close to the boiler.

Expansion Tank and Make-Up Water

1. Ensure that the expansion tank is sized to correctly handle boiler and system water volume and temperature.

WARNING	
Expansion tanks must be sized according to total system volume. This includes all length of pipe, all fixtures, boilers, etc. Failure to properly size for system expansion could result in wasted time, money, possible property damage, serious injury, or death.	
CAUTION	
Undersized expansion tanks cause system water to be lost from the relief valve, causing make-up water to be added. Eventual boiler failure can result due to excessive make-up water addition. SUCH FAILURE IS NOT COVERED BY WARRANTY.	
DO NOT install automatic air vents on closed type expansion tank systems. Air must remain in the system and return to the tank to provide an air cushion. An automatic air vent would cause air to leave the system, resulting in improper operation of the expansion tank.	
The expansion tank must be suitable for hot potable water systems.	

Expansion Tank Sizing*	
VWH Model	Heat Exchanger Volume (Gallons)
500	4.2
700/850	5.8

Table 7 - *Add Required Storage Tank Gallon Size to Heat Exchanger Volume - 119 and 175 Gallon Tanks Available - Larger Storage Tanks are Available Upon Request - Contact HTP Customer Service for more information.

2. The expansion tank must be located as shown in Applications, this manual, or following recognized design methods. See expansion tank manufacturer's instructions for details.

E. Circulators

Every VWH system requires special attention to circulator size to overcome pressure drop through the boiler and its related piping. All circulators installed on the VWH system must be designed for potable water installations. Boiler pressure drop is detailed in this manual.

CAUTION	
Water temperature above 140°F requires the circulator to run continuously. Water hardness must be between 5 and 7 grains. Hardness above 7 grains will damage the heat exchanger and shorten the service life of the boiler.	
DO NOT use the boiler circulator in any location other than the ones shown in this manual. The boiler circulator location is selected to ensure adequate flow through the boiler. Failure to comply with this caution could result in unreliable performance and nuisance shutdowns from insufficient flow.	

F. Scalding

This boiler can deliver scalding water at any faucet in the system. Be careful whenever using hot water to avoid scalding injury. Certain appliances such as dishwashers and automatic clothes washers may require increased water temperatures. By setting the thermostat on this boiler to obtain the increased water temperature required by these appliances you may create the potential for scald injury.

To protect against injury, install a mixing valve in the water system. This valve will reduce point of use discharge temperatures by mixing cold and hot water in branch supply lines. Such valves are available from your local plumbing supplier.

Table 8 details the relationship of water temperature and time with regard to scald injury and may be used as a guide in determining the safest water temperature for your applications.

! DANGER

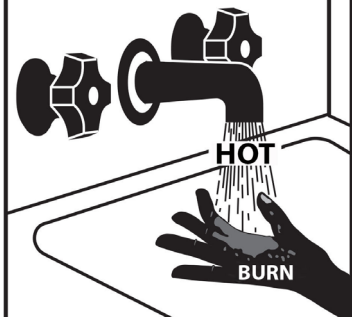

Water temperature over 125°F can cause severe burns instantly or death from scalds. Children, disabled and elderly are at highest risk of being scalded. See instruction manual before setting temperature at water heater. Feel water before bathing or showering. Temperature limiting valves are available, see manual.

WARNING	
The risk of scalding increases when raising tank temperature. Use a water tempering or mixing valve when raising tank temperature to lessen the chance of scalds. Consult codes for conformance. Failure to install a temperature limiting or mixing valve and follow these instructions could result in property damage, severe personal injury, or death due to scalds.	

Approximate Time / Temperature Relationships in Scalds	
120°F	More than 5 minutes
125°F	1 1/2 to 2 minutes
130°F	About 30 seconds
135°F	About 10 seconds
140°F	Less than 5 seconds
145°F	Less than 3 seconds
150°F	About 1 1/2 seconds
155°F	About 1 second

Table 8 - Approximate Time / Temperature Relationships in Scalds

G. High Velocity Circulator Pump

Every VWH system requires special attention to pump size in order to overcome pressure drop through the boiler and its related piping. All circulators installed on the VWH system must be designed for a potable water system.

In addition, the heat exchanger has a minimum total water volume that must be taken into account when sizing the circulator. Minimum flow rates are listed in the table below.

Minimum Boiler Flow Rates	
VWH Model	Minimum Flow (GPM)
500	33
700/850	54

Table 9 - Minimum Flow Rates

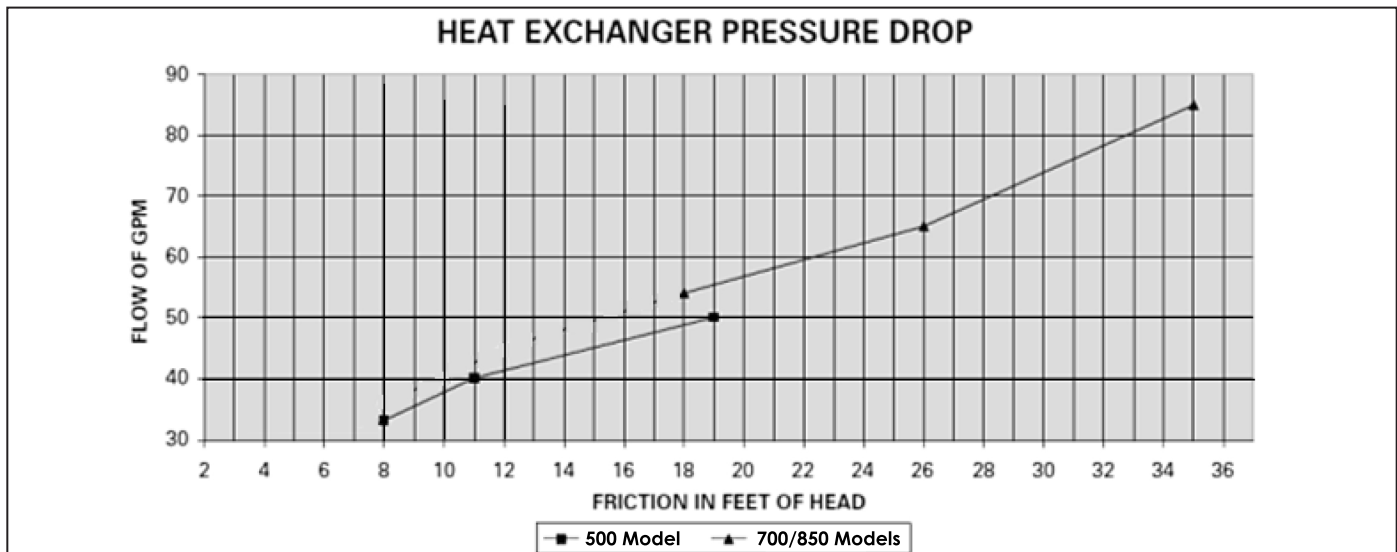

Table 10 - Heat Exchanger Pressure Drop

The chart below represents various system design temperature rise through the boiler along with respective flows and friction loss. This is provided to aid in circulator selection.

System Temperature Rise Chart						
	20°Δt		25°Δt		30°Δt	
Model	Friction Ft	Flow Rate (GPM)	Friction Ft	Flow Rate (GPM)	Friction Ft	Flow Rate (GPM)
500	19'	50	11'	40	8'	33
700/850	35'	85	26'	65	18'	54

Table 11 - Temperature Rise, Friction Feet, and Flow Rate

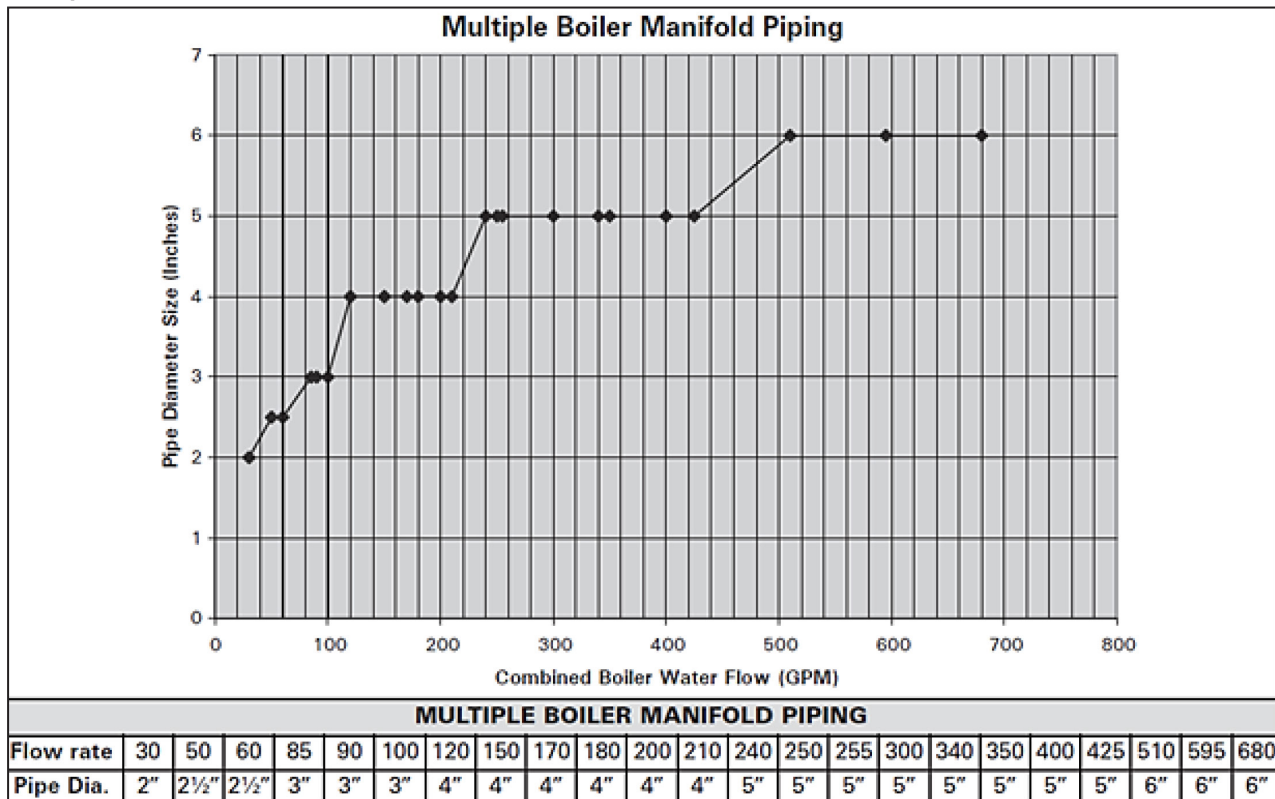

Table 12 - Multiple Boiler Manifold Piping

H. Water Chemistry

CAUTION

Chemical imbalance of the water supply may affect efficiency and cause severe damage to the appliance and associated equipment. Water quality must be professionally analyzed to determine whether it is necessary to treat the water. Various solutions are available to adjust water quality. Adverse water quality will affect the reliability of the system. In addition, operating temperatures above 135°F will accelerate the build-up of lime scale and possibly shorten appliance service life. Failure of an appliance due to lime scale build-up, low pH, or other chemical imbalance IS NOT covered by the warranty.

The water must be potable, free of corrosive chemicals, sand, dirt, and other contaminants. It is up to the installer to ensure the water does not contain corrosive chemicals or elements that can damage the heat exchanger. Potable water is defined as drinkable water supplied from utility or well water in compliance with EPA secondary maximum contaminant levels (40 CFR Part 143.3) as shown in the table below. If the water contains contaminants higher than outlined by the EPA, water treatment is recommended and additional, more frequent maintenance may be required.

If you suspect that your water is contaminated in any way, discontinue use of the appliance and contact an authorized technician or licensed professional.

Contaminant	Maximum Allowable Level	Contaminant	Maximum Allowable Level
Total Hardness (Commercial Use - 140°F and above water temperature)	120 mg/l (7 grains/gallon)	pH	6.5-8.5
		Sulfate	205 mg/l
		Total Dissolved Solids (TDS)	500 mg/l
Aluminum	0.05 to 0.2 mg/l	Zinc	5 mg/l
Chloride	100 mg/l		
Copper	1 mg/l	Dissolved Carbon Dioxide (CO ₂)	15 mg/l or PPM
Iron	0.3 mg/l		
Manganese	0.05 mg/l		

***NOTE:** It is recommended to clean heat exchanger at least once a year to prevent lime scale buildup. Follow the maintenance procedure in the Maintenance Section of this manual to clean the heat exchanger.

Piping components

Water heating system piping

System piping MUST be sized per technical pipe requirements listed in this manual. Reducing pipe size can restrict flow rate through the boiler, causing inadvertent short cycling and poor system performance.

Check valves

Field supplied. Check valves are recommended for installation as shown in Piping Details.

Boiler isolation valves

Field supplied. Full port ball valves are required. Failure to use full port ball valves could result in a restricted flow rate through the boiler.

Anti-scald mixing valve

Field supplied. A thermostatic mixing valve is recommended when storing domestic hot water above 115°F.

Unions

Field supplied: Recommended for unit serviceability. DO NOT USE

DIELECTRIC UNIONS!

ONLY BRASS, COPPER, OR STAINLESS STEEL.

Pressure relief valve

Factory supplied on VWH. The pressure relief valve is sized to ASME specifications. Storage tank may require additional relief valves depending on local codes.

I. Applications

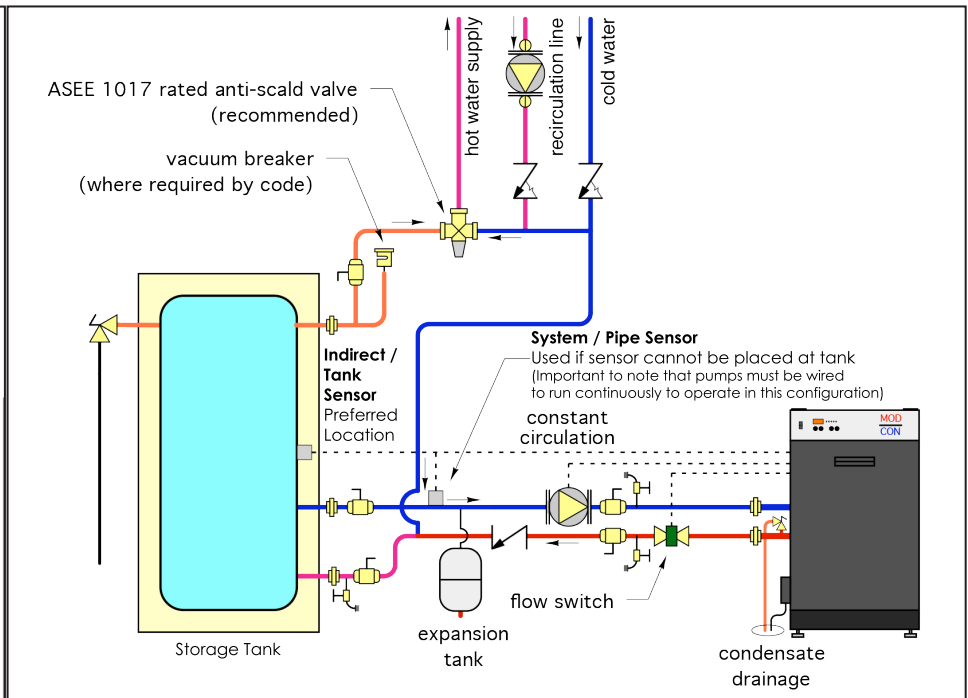
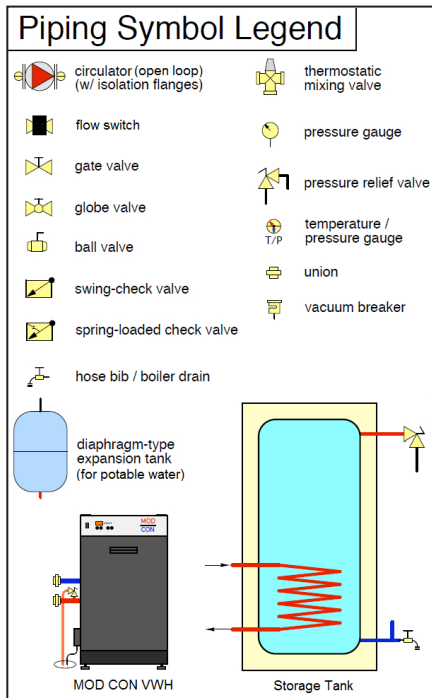

Figure 6 - Piping Legend

Figure 7 - VWH Boiler with Storage Tank

FIGURE NOTES:

1. This drawing is meant to show system piping concept only. Installer is responsible for all equipment & detailing required by local codes.
2. Boiler circulator must be rated for open loop application. Do not use cast-iron circulators.
3. Boiler circulator(s) operate continuously.
4. The minimum pipe size for connecting a storage tank is 1 1/2".
5. The minimum pipe size for connecting a boiler is 2". When sizing and installing a multiple boiler system, see Multiple Boiler Manifold Piping Chart, this manual.
6. All pumps are shown with isolation flanges or full port ball valves for isolation. The alternative is standard flanges with full port ball valves and a separate flow check valve.
7. Install a minimum of 12 diameters of straight pipe upstream of all circulators and check valves.
8. Install vacuum relief valve in accordance with local code requirements.
9. Multiple boilers and storage tanks shall be installed with reverse return piping (as shown).
10. Expansion tank must be rated for use with potable water.
11. Use either indirect/tank sensor or system/pipe sensor mounted on common return to the boiler.
12. Aquastat or system/pipe sensor connects to DHW sensor input on boiler.
13. The minimum storage tank size for a 500VWH is 119 gallons. The minimum storage tank size for a 700/850VWH is 175 gallons.

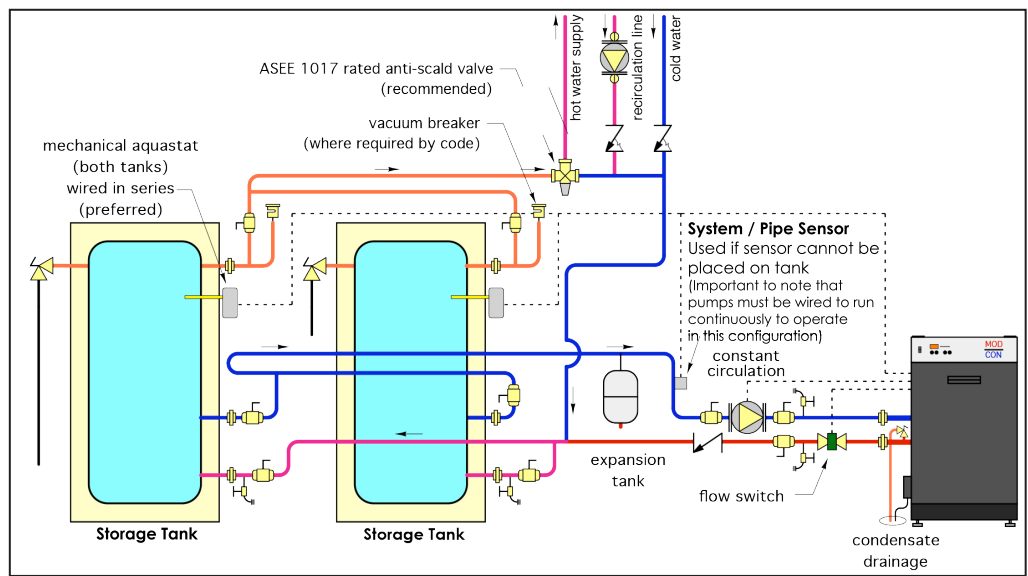

Figure 8 - VWH Boiler with Two Storage Tanks

⚠ WARNING

An ASSE 1017 thermostatic mixing valve is recommended on all tanks if the hot water temperature leaving the tank is above 119°F. Failure to do so could result in substantial property damage, serious injury, or death.

The piping will not support the weight of the circulators. Refer to the circulator manufacturer's instructions to properly support the circulator. Failure to comply with these instructions could result in property damage, severe personal injury, or death.

FIGURE NOTES:

1. This drawing is meant to show system piping concept only. Installer is responsible for all equipment & detailing required by local codes.
2. Boiler circulator must be rated for open loop application. Do not use cast-iron circulators.
3. Boiler circulator(s) operate continuously.
4. The minimum pipe size for connecting a storage tank is 1 1/2".
5. The minimum pipe size for connecting a boiler is 2". When sizing and installing a multiple boiler system, see Multiple Boiler Manifold Piping Chart, this manual.
6. All pumps are shown with isolation flanges or full port ball valves for isolation. The alternative is standard flanges with full port ball valves and a separate flow check valve.
7. Install a minimum of 12 diameters of straight pipe upstream of all circulators and check valves.
8. Install vacuum relief valve in accordance with local code requirements.
9. Multiple boilers and storage tanks shall be installed with reverse return piping (as shown).
10. Expansion tank must be rated for use with potable water.
11. Use either indirect/tank sensor or system/pipe sensor mounted on common return to the boiler.
12. Wire the tank or system/pipe sensor to the DHW sensor terminals input on the follower boiler addressed as #1.
13. Wire the tank or system / pipe sensor connected to the DHW sensor terminals on the follower boiler addressed as #1.
14. The system / pipe sensor must be placed on common piping to the tank as close to the tank as possible.
15. The system / pipe sensor is wired to the system sensor terminals on the master boiler.
16. The minimum storage tank size for a 500VWH is 119 gallons. The minimum storage tank size for a 700/850VWH is 175 gallons.

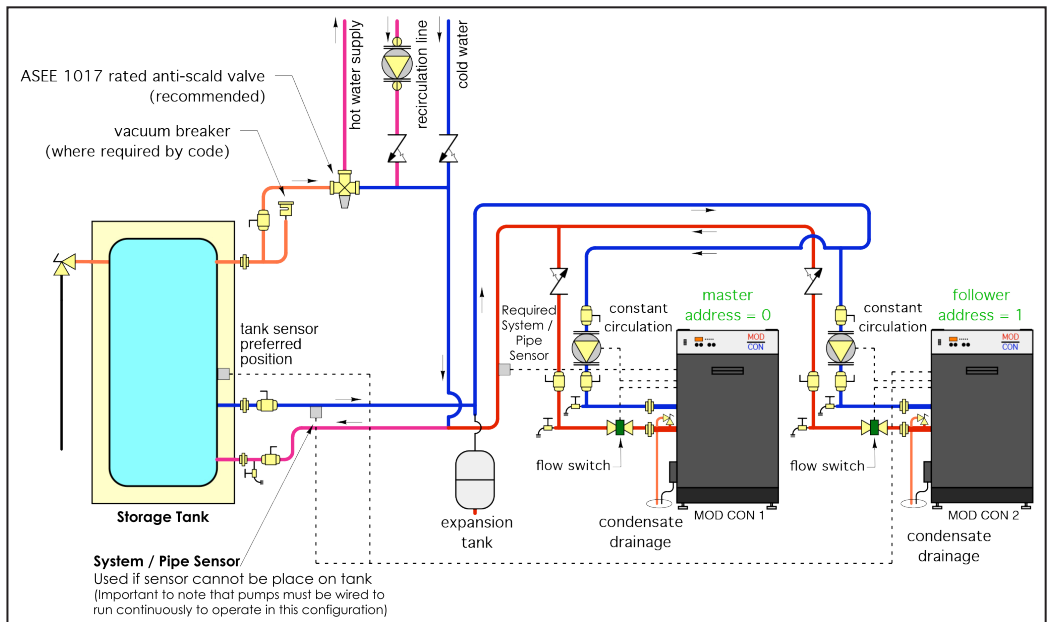
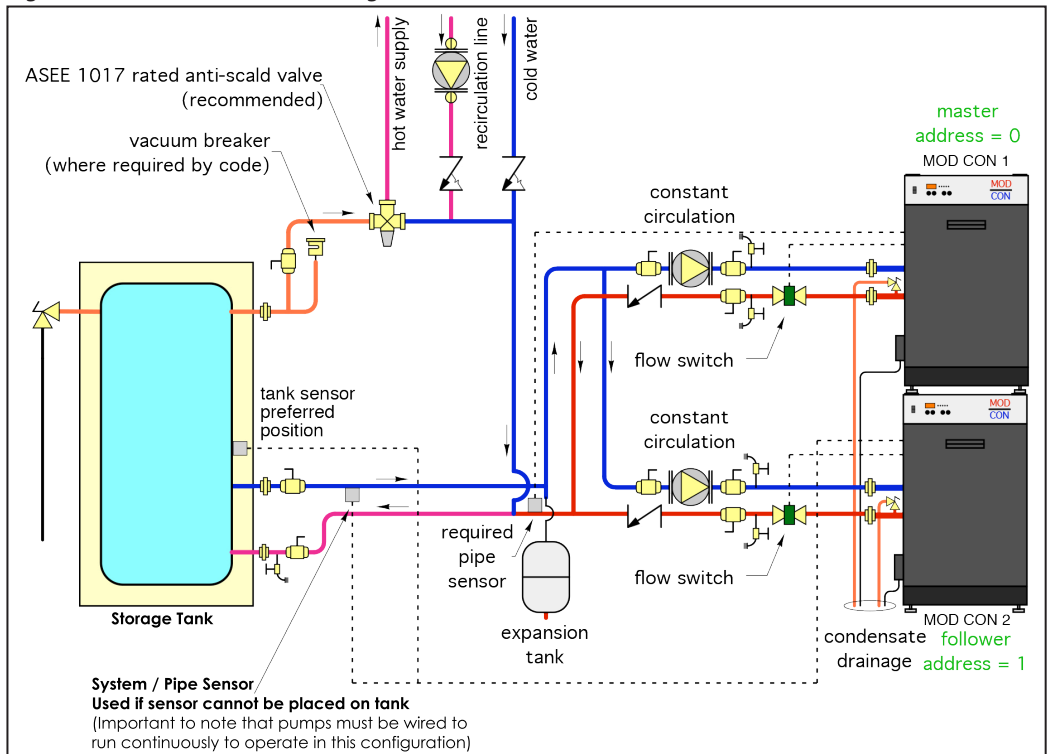
**Figure 9 - Two VWH Boilers with Storage Tank****Figure 10 - Two Stacked VWH Boilers with Storage Tank****WARNING**

An ASSE 1017 thermostatic mixing valve is recommended on all tanks if the hot water temperature leaving the tank is above 119°F. Failure to do so could result in substantial property damage, serious injury, or death.

The piping will not support the weight of the circulators. Refer to the circulator manufacturer's instructions to properly support the circulator. Failure to comply with these instructions could result in property damage, severe personal injury, or death.

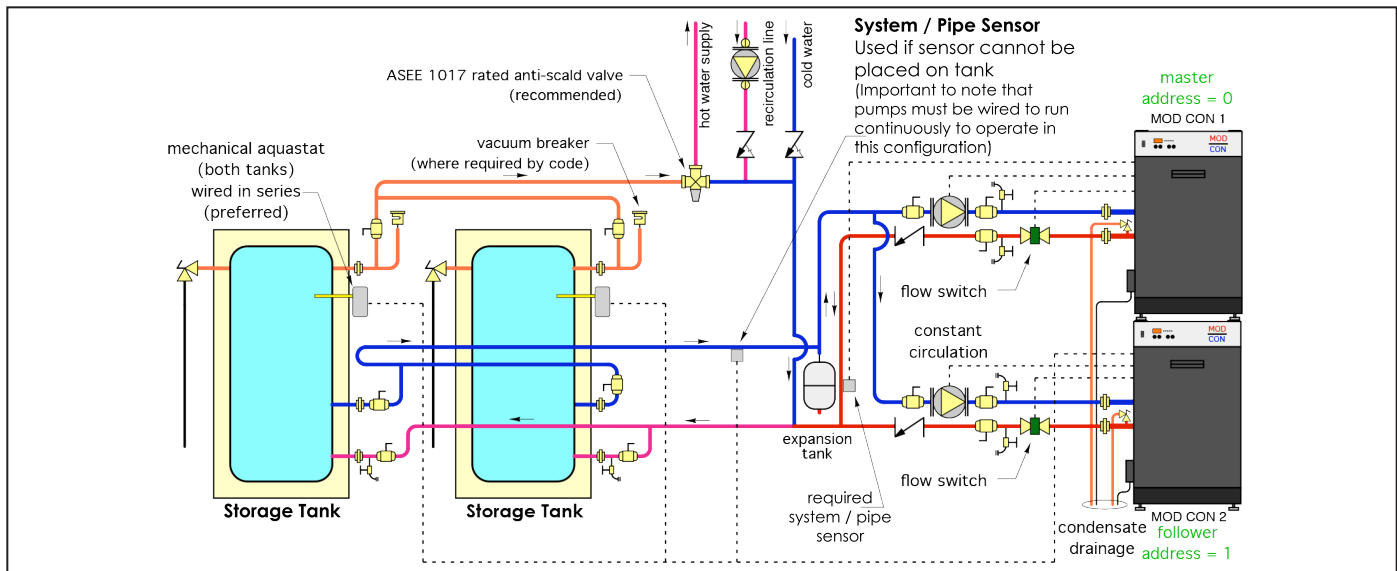

Figure 11 - Two Stacked VWH Boilers with Two Storage Tanks

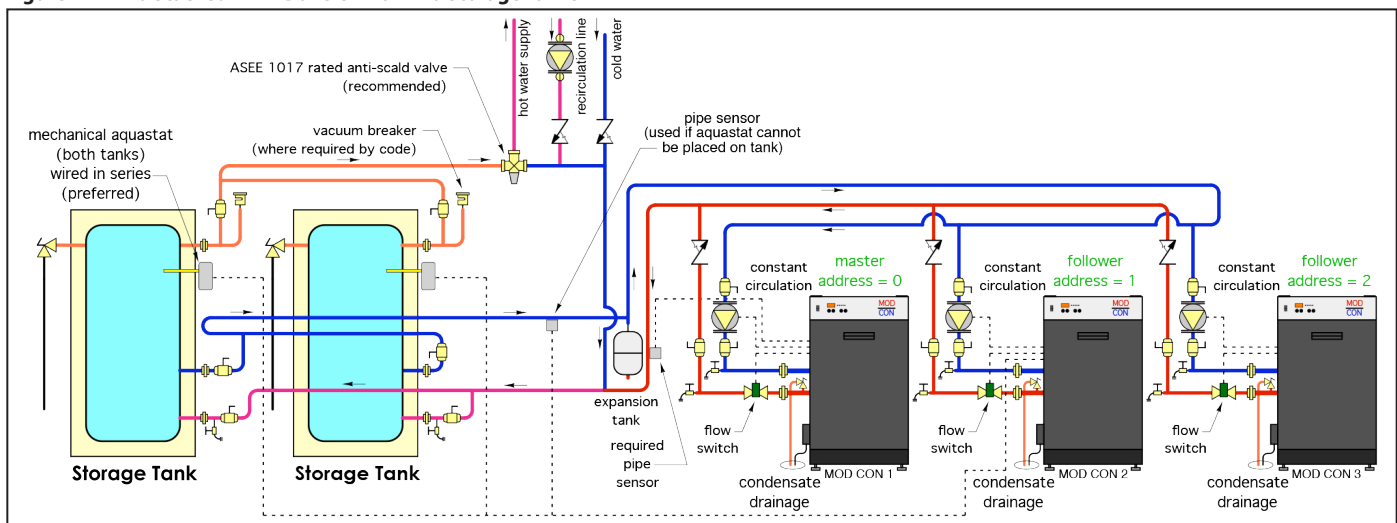

Figure 12 - Three VWH Boilers with Two Storage Tanks

FIGURE NOTES:

1. This drawing is meant to show system piping concept only. Installer is responsible for all equipment & detailing required by local codes.
2. Boiler circulator must be rated for open loop application. Do not use cast-iron circulators.
3. Boiler circulator(s) operate continuously.
4. The minimum pipe size for connecting a storage tank is 1 1/2".
5. The minimum pipe size for connecting a boiler is 2". When sizing and installing a multiple boiler system, see Multiple Boiler Manifold Piping Chart, this manual.
6. All pumps are shown with isolation flanges or full port ball valves for isolation. The alternative is standard flanges with full port ball valves and a separate flow check valve.
7. Install a minimum of 12 diameters of straight pipe upstream of all circulators and check valves.
8. Install vacuum relief valve in accordance with local code requirements.
9. Multiple boilers and storage tanks shall be installed with reverse return piping (as shown).
10. Expansion tank must be rated for use with potable water.
11. Use either indirect/tank sensor or system/pipe sensor mounted on common return to the boiler.
12. Wire the tank or system/pipe sensor to the DHW sensor terminals input on the follower boiler addressed as #1.
13. Wire the tank or system / pipe sensor connected to the DHW sensor terminals on the follower boiler addressed as #1.
14. The system / pipe sensor must be placed on common piping to the tank as close to the tank as possible.
15. The system / pipe sensor is wired to the system sensor terminals on the master boiler.
16. The minimum storage tank size for a 500VWH is 119 gallons. The minimum storage tank size for a 700/850VWH is 175 gallons.

WARNING

An ASSE 1017 thermostatic mixing valve is recommended on all tanks if the hot water temperature leaving the tank is above 119°F. Failure to do so could result in substantial property damage, serious injury, or death.

The piping will not support the weight of the circulators. Refer to the circulator manufacturer's instructions to properly support the circulator. Failure to comply with these instructions could result in property damage, severe personal injury, or death.

Part 5 - Venting

⚠ DANGER

The boiler must be vented as detailed in this section. Ensure exhaust vent and intake piping complies with these instructions regarding vent system. Inspect finished exhaust vent and intake piping thoroughly to ensure all joints are well secured, airtight, and comply with all applicable code requirements, as well as the instructions provided in this manual. Failure to properly install the vent system will result in severe personal injury or death.

A. General

⚠ DANGER

This boiler is certified as a "Category IV" appliance and requires a special venting system. The vent system will operate with a positive pressure in the pipe. Exhaust gases must be piped directly outdoors using the vent materials and rules outlined in these instructions. Do not connect vent connectors serving appliances vented by natural draft into any portion of mechanical draft systems operating under positive pressure. Follow the venting instructions carefully. Failure to do so will result in substantial property damage, severe personal injury, or death.

1. Installation should be made in accordance with the regulations of the Authority Having Jurisdiction, local code authorities, and utility companies which pertain to this type of water heating equipment.
2. Install the venting system in accordance with these instructions and with the National Fuel Gas Code, ANSI Z223.1/NFPA 54, CAN/CGA B149, and / or applicable provisions of local building codes.
3. This boiler must be vented with materials, components, and systems listed and approved for Category IV appliances.

⚠ DANGER

Exhaust and intake are to be piped separately. This boiler cannot share a common exhaust or intake with multiple appliances. Failure to follow these instructions will result in substantial property damage, severe personal injury, or death.

NOTE: To avoid contamination often contained in indoor air, it is best to pipe all intake combustion air directly to the outdoors.
NOTE: Care must be taken to prevent condensate freezing in the exhaust vent pipe system. See local, state, provincial, and national codes for best practices to prevent condensate freezing in the exhaust vent pipe system.

⚠ WARNING

Improper seating of vent pipe gaskets can cause eventual gasket failure and exhaust gas leakage. Ensure the exhaust vent pipe is properly beveled and seated before insertion into the flue adapter. Failure to do so could result in property damage, severe personal injury, or death.

Exhaust vent adaptors are not designed as load-bearing devices, and must not be used to support exhaust vent piping. All vent pipes must be properly connected, supported, and the exhaust vent must be pitched a minimum of 1/4" per foot back to the boiler to allow drainage of condensate. Failure to properly support vent piping and follow the information in this statement could result in product damage, severe personal injury, or death.

⚠ WARNING

Breathing Hazard - Carbon Monoxide Gas



- Do not operate heater if flood damaged.
- Install vent system in accordance with local codes and manufacturers installation instructions.
- Do not obstruct heater air intake or exhaust. Support all vent piping per manufacturers installation instructions.
- Do not place chemical vapor emitting products near unit.
- According to NFPA 720, carbon monoxide detectors should be installed outside each sleeping area.
- Never operate the heater unless it is vented to the outdoors.
- Analyze the entire vent system to make sure that condensate will not become trapped in a section of vent pipe and therefore reduce the open cross sectional area of the vent.

Breathing carbon monoxide can cause brain damage or death. Always read and understand instruction manual.

LP-304

⚠ DANGER

Due to the extreme flammability of most glues, cements, solvents, and primers used to join plastic exhaust vent and intake pipes, explosive solvent vapors must be cleared from all vent piping before start-up. Avoid using excess cement or primer, as this may pool in the vent pipes. Vent assemblies should be allowed to cure for a period of at least 8 hours before powering a connected appliance. Failure to follow these instructions will result in substantial property damage, severe personal injury, or death. It is the installers' responsibility to understand the hazards associated with explosive solvents and take the necessary precautions to avoid these risks.

⚠ WARNING

- DO NOT insulate the first three (3) linear feet of the exhaust vent run.
- CPVC, Polypropylene, or Stainless Steel pipe material MUST be used if the first three (3) linear feet of the exhaust vent run is insulated or passes through an enclosed space greater than 6" in length, such as a wall. **NOTE:** Only Stainless Steel pipe material may be insulated.
- If CPVC is used to meet these requirements, the balance may be installed with approved PVC pipe.
- If Polypropylene or Stainless Steel is used to meet these requirements, the balance of the vent run must be installed with the same material.
- Failure to comply with this warning could result in property damage, severe personal injury, or death.

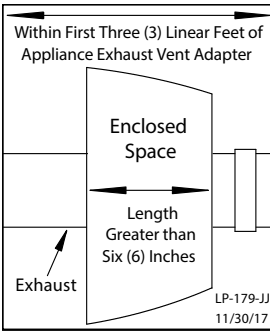

LP-179-JJ
11/30/17

It is required to insert exhaust and intake screens into the vent terminations to prevent blockage caused by debris or birds. Failure to keep terminations clear could result in property damage, severe personal injury, or death.

B. Approved Materials for Exhaust Vent and Intake Pipe

Item	Material	Standards for Installation In:	
		United States	Canada
Pipe and Fittings Approved for Intake ONLY	ABS*	ANSI/ASTM D2661	ANSI/ASTM D2661
Pipe Approved for Intake OR Exhaust Vent	PVC Schedule 40/80	UL-1738 or ANSI/ASTM D1785	UL-1738 or ULC-S636
	PVC-DWV Schedule 40/80	UL-1738 or ANSI/ASTM D2665	
	CPVC Schedule 40/80	UL-1738 or ANSI/ASTM F441	
	Polypropylene	UL-1738 or ULC-S636	
	Stainless Steel AL29-4C	Certified for Category IV and Direct Vent Appliance Venting	
Pipe Fittings	PVC Schedule 40	UL-1738, ANSI/ASTM D2466 or D2665	UL-1738 or ULC-S636
	PVC Schedule 80	UL-1738, ANSI/ASTM D2467 or D2665	
	CPVC Schedule 40	UL-1738 or ANSI/ASTM F438	
	CPVC Schedule 80	UL-1738 or ANSI/ASTM F439	
Pipe Cement	ABS*	ANSI/ASTM D2235	ANSI/ASTM D2235
	PVC	ANSI/ASTM D2564	IPEX System 636 Cements and Primers
	CPVC	ANSI/ASTM F493	
Pipe Primer	PVC / CPVC	ASTM F656	

! DANGER

- The exhaust and intake components installed with this appliance must be used for near appliance piping BEFORE transitioning to the approved materials listed above. DO NOT REMOVE these installed components. Doing so WILL VOID appliance warranty.
 - PVC / CPVC pipe and fittings of the same diameter are considered interchangeable.
 - The use of cellular core PVC (ASTM F891), cellular core CPVC, or Radel® (polyphenolsulfone) in non-metallic venting systems is prohibited.
 - Covering non-metallic vent pipe and fittings with thermal insulation is prohibited.
 - DO NOT connect PVC/CPVC to Polypropylene without an approved vent connector.
 - Any transition to Polypropylene MUST be done in the vertical within five (5) feet of the appliance.
 - When installing AL29-4C vent piping, install a PVC-to-stainless adapter at the appliance vent connection, and at the termination when using a PVC termination kit. DO NOT mix AL29-4C piping from different manufacturers unless using adapters specifically designed for the purpose by the manufacturer.
 - A double wall vent or insulated material may be used when using stainless steel vent material in a freezing climate.
 - *ABS may be used for air intake applications ONLY. ABS is NOT PERMITTED for use in Canada.
 - Contact the venting material manufacturer if there is any question about the applicability of the proposed venting material.
- Failure to follow these directions will result in substantial property damage, severe personal injury, or death.

Table 13 - Approved Materials for Exhaust Vent and Intake Pipe

! WARNING
DO NOT mix components from different venting systems without proper adapters. The vent system could fail, causing leakage of flue products into the living space. Use only the approved pipe and fitting materials, and primer and cement specifically designed for the material used, as listed in the above table. Failure to do so could result in property damage, serious injury, or death.
CAUTION
High heat sources (generating heat 100°F / 37°C or greater, such as boiler flue pipes, space heaters, etc.) may damage plastic components of the boiler as well as plastic vent pipe materials. Such damages ARE NOT covered by warranty. It is recommended to keep a minimum clearance of 8" from high heat sources. Observe heat source manufacturer instructions, as well as local, state, provincial, and national codes, laws, regulations, and ordinances when installing this boiler and related components near high heat sources.

NOTE: The use of double-wall vent or insulated material for the combustion air intake pipe is recommended in cold climates to prevent the condensation of airborne moisture in the incoming combustion air.

! DANGER

You must not use "B" vent in an exhaust application. "B" vent is for intake applications ONLY. Using "B" vent in an exhaust application will result in serious injury or death.

C. Additional Requirements for Installation in Canada

1. Installations must be made with a vent pipe system certified to ULC-S636. IPEX is an approved vent manufacturer in Canada supplying vent material listed to ULC-S636. Additionally, you may use AL29-4C stainless steel venting to comply with Canadian requirements.
2. The first three (3) feet of vent pipe from the boiler flue outlet must be readily accessible for visual inspection.
3. The components of the certified vent system must not be interchanged with other vent systems or unlisted pipe / fittings.

D. Exhaust Vent and Intake Pipe Location

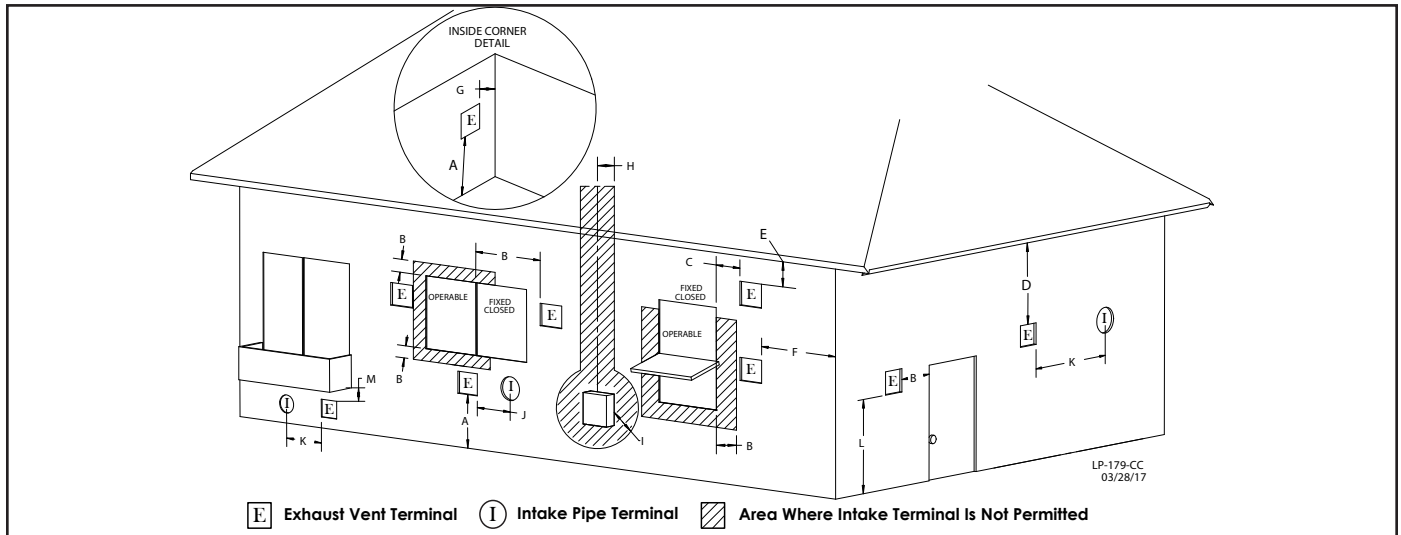

Figure 13 - Exit Terminals for Direct Vent Systems - ANSI Z223.1 / NFPA 54 for US and CAN/CSA B149.1 for Canada

DESCRIPTION		US	CANADA
A	Clearance above grade, veranda, porch, deck, or balcony	1 foot (30 cm)	
B	Clearance to window or door that may be opened	Direct Vent	3 feet (91 cm)
		Power Vent	
C	Clearance to permanently closed window	*	
D	Vertical clearance to ventilated soffit located above the terminal within a horizontal distance 2 feet (61 cm) from the center line of the terminal	*	
E	Clearance to unventilated soffit	*	
F	Clearance to outside corner	*	
G	Clearance to inside corner	*	
H	Clearance to each side of center line extended above meter / regulator assembly	*	
I	Clearance to service regulator vent outlet	*	Above a regulator within 3 feet (91 cm) horizontally of the vertical center line of the regulator vent outlet to a maximum vertical distance of 15 ft (4.5 m)
J	Clearance to nonmechanical air supply inlet to building or the combustion air inlet to any other appliance	Direct Vent	3 feet (91 cm)
		Power Vent	
K	Clearance to mechanical air supply inlet	3 feet above if within 10 feet horizontally	6 feet (1.83 m)
L	Clearance above paved sidewalk or paved driveway located on public property	Direct Vent	7 feet (2.13 m)
		Power Vent	
M	Clearance under veranda, porch deck, or balcony	*	1 foot (30 cm)

Table 14 - Vent Termination Clearances - *NOTE: For clearances not specified in ANSI Z223.1 / NFPA 54 for US and CAN/CSA B149.1 for Canada, please use clearances in accordance with local installation codes and the requirements of the gas supplier.

WARNING

The building owner is responsible for keeping the exhaust and intake terminations free of snow, ice, or other potential blockages, as well as scheduling routing maintenance. Failure to keep the vent piping terminations clear and properly maintain the heater could result in property damage, severe personal injury, or death.

WARNING

For each floor containing bedroom(s), a carbon monoxide detector and alarm shall be placed in the living area outside the bedrooms, as well as in the room that houses the heater. Detectors and alarms shall comply with NFPA 720 (latest edition). Failure to comply with these requirements could result in product damage, severe personal injury, or death.

E. Exhaust Vent and Intake Pipe Sizing

- The exhaust vent and intake pipe size is 4" for the 500 model and 6" for the 700/850 models.
- The maximum total equivalent length of exhaust vent and intake pipe **should not exceed 200 feet**.
 - The equivalent length of elbows, tees, and other fittings are listed in the Friction Loss Table.

Friction Loss Equivalent in Piping and Fittings			
Fittings or Piping	Equivalent Feet		
	4"	6"	8"
90 Degree Elbow*	3'	3'	3'
45 Degree Elbow	1'	1'	1'
Coupling	0'	0'	0'
Air Inlet Tee	0'	0'	0'
Straight Pipe	1'	1'	1'
V Series Vent Kit	1'	1'	1'
AL20 4c Vent Terminal	1'	1'	1'

Table 15 - *Friction loss for long radius elbow is 1 foot less. NOTE: Consult Polypropylene venting instructions for friction loss and pressure drop equivalents.

- For example: If the exhaust vent is 4" in diameter, has two 90° elbows, and 10 feet of PVC pipe we will calculate:
 Exhaust Vent Equivalent Length = (2x3) + 10 = 16 feet.
 Further, if the 4" intake pipe has two 90° elbows, one 45° elbow, and 10 feet of PVC pipe, the following calculation applies:
 Intake Pipe Equivalent Length = (2x3) + 1 + 10 = 17 feet.
 The total equivalent length is 33 feet, well below the maximum of 140 feet.
 - Effort should be made to keep a minimum difference in equivalent length between the exhaust vent and intake pipe.
- The minimum total equivalent length is 16 feet.

CAUTION

Do not exceed the maximum lengths for vent pipes. Excessive length could result in boiler shutdown and property damage.

Failure to provide a minimum total vent length of 16 equivalent feet could result in property damage and improper product operation.

F. Longer Vent Runs

The maximum total equivalent length can be extended by increasing the diameter of both the exhaust vent and intake pipes equally. However, the transitions should begin a minimum of 16 equivalent feet from the boiler. Transitions should always be made in vertical sections of pipe to prevent the condensate from pooling in the vent pipe.

The maximum equivalent length for increased diameter vent pipes is 275 ft, which includes 16 ft from with boiler with a transition total of 259 ft upsize piping for longer vent runs.

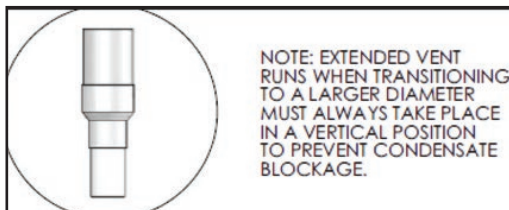

Figure 14 - Extended Vent Runs

Standard Vent Connection and Maximum Total Equivalent Length	Reducing Coupling	Increased Vent Size and Maximum Total Equivalent Length
4" (200')	6" x 4"	6" (275')
6" (200')	8" x 6"	8" (275')

Table 16 - Vent Run Transition

⚠ DANGER

Total maximum equivalent length of increased diameter exhaust vent and intake pipe must not exceed the lengths defined in this manual. Failure to keep the total equivalent length below the maximum lengths determined in this manual will result in faulty boiler operation, substantial property damage, serious personal injury, or death.

G. Exhaust Vent and Intake Pipe Installation

⚠ WARNING

All joints of positive pressure vent systems must be sealed completely to prevent leakage of flue products into the living space. Failure to do so could result in property damage, serious injury, or death.

- Use only solid PVC, CPVC, or stainless steel pipe or a Polypropylene vent system approved for use with Category IV appliances. ABS pipe material may be used on air intake piping **only**.
- Remove all burrs and debris from joints and fittings.
- When using PVC or CPVC pipe, all joints must be properly cleaned, primed, and cemented. Use only cement and primer approved for use with the pipe material. Cement must conform to ASTM D2564 for PVC and ASTM F493 for CPVC pipe. **NOTE: DO NOT CEMENT POLYPROPYLENE PIPE.**
- Ensure the vent is located where it will not be exposed to prevailing winds.
- In all roof venting applications, exhaust discharge must point away from the pitch of the roof.
- If the exhaust vent is to be terminated in a walled off area (such as a roof with a parapet wall), ensure the exhaust vent terminates a minimum of 10' from nearest wall and extends level with or above the top of the wall. This will ensure flue gas does not get trapped and possibly recirculated into the intake air pipe, which could contaminate the combustion air.
- To prevent water leakage, install adequate roof flashing where the pipe enters the roof.
- Do not locate vent over public walkways, driveways, or parking lots. Condensate could drip and freeze, resulting in a slip hazard or damage to vehicles and machinery.
- Due to potential moisture build-up, sidewall venting may not be the preferred venting option. To save time and cost, carefully consider venting installation and location.
- Horizontal lengths of exhaust vent must slope back towards the boiler not less than ¼" per foot to allow condensate to drain from the vent pipe.
- The exhaust vent must terminate where vapors cannot make accidental contact with people or pets, or damage shrubs or plants.
- In vacant chimney applications, install and seal a rain cap over existing chimney openings.
- All piping must be fully supported. Use pipe hangers at a minimum of 4 foot intervals to prevent sagging of the pipe where condensate may form.
- Do not use the boiler to support any piping.
- Ensure the outdoor exhaust vent termination is screened to prevent blockage caused by debris or birds.

16. Ensure the outdoor intake pipe termination is screened to prevent blockage caused by debris or birds.

17. Maximum Snow Level Determination: These installation instructions reference snow levels in establishing a minimum height for the installation of exhaust vent or air intake terminations. Snow levels shall be determined as follows:

- The installation location may, by ordinance, designate how snow levels are calculated in that location; or
- In the absence of specific ordinances, snow levels shall be calculated from the average monthly maximum depth of snow accumulation as indicated by the National Weather Service's 10 year statistics for the installation location/geographical area.

In addition:

- Total length of vent piping shall not exceed the limits specified in this manual.
- The vent piping for this direct vented appliance is approved for zero clearance to combustible construction.
- The flue products coming from the exhaust vent will create a large plume when the heater is in operation. Avoid venting in areas that will affect neighboring buildings or be considered objectionable.
- DO NOT locate exhaust vent or intake pipe in a parking area where machinery may damage the pipe.
- DO NOT vent near soffit vents, crawl space vents, or other areas where condensate or vapor could create a nuisance or hazard or cause property damage.
- DO NOT vent where condensate vapor could cause damage or could be detrimental to the operation of regulators, relief valve, or other equipment.

In the Commonwealth of Massachusetts and as Required by State and Local Codes:

- The vented gas fueled appliance shall not be installed so its combustion, ventilation, or dilution air is obtained from a bedroom or bathroom.
- Signage: Whenever any through-the-wall (horizontal or sidewall) vent is installed less than seven feet above the finished grade, a metal or plastic identification plate shall be permanently mounted to the exterior of the building at a minimum height of eight feet above grade directly in line with the exhaust vent terminal. The sign shall read, in print no less than 0.5 inches in size, "GAS VENT DIRECTLY BELOW. KEEP CLEAR OF ALL OBSTRUCTIONS".
- Marking of Exhaust Vent and Intake Pipe: Piping used for ventilation, make-up, or combustion air intake shall be labeled as follows:
 - Throughout the entire developed length:
 - Labels must be placed every ten feet for exposed/visible piping; or
 - Labels must be placed every three feet for concealed piping.
 - At all changes of direction;
 - On each side of a penetration through a partition, wall or ceiling; and
 - The labels shall be black lettering that:
 - Indicates that the piping is used for ventilation, make-up, or combustion air intake, and
 - The letters shall be sized equal to a minimum of the pipe diameter. However, for piping with a diameter exceeding two inches, said lettering does not need to be larger than two inches.

H. Applications

1. Direct Vent Installation of Exhaust and Intake

If installing a direct vent option, combustion air must be drawn from the outdoors directly into the boiler intake, and exhaust must terminate outside. There are three basic direct vent options detailed in this manual: 1. Side Wall Venting, 2. Roof Venting, and 3. Unbalanced Venting.

Be sure to locate the boiler such that the exhaust vent and intake pipe can be routed through the building and properly terminated. Different vent terminals can be used to simplify and eliminate multiple penetrations in the building structure (see Optional Equipment in Venting Section). The exhaust vent and intake pipe lengths, routing and termination methods must all comply with the methods and limits given in the Venting section of this manual.

When installing a combustion air intake from outdoors, care must be taken to utilize uncontaminated combustion air. **NOTE:** To prevent combustion air contamination, see Table 4.

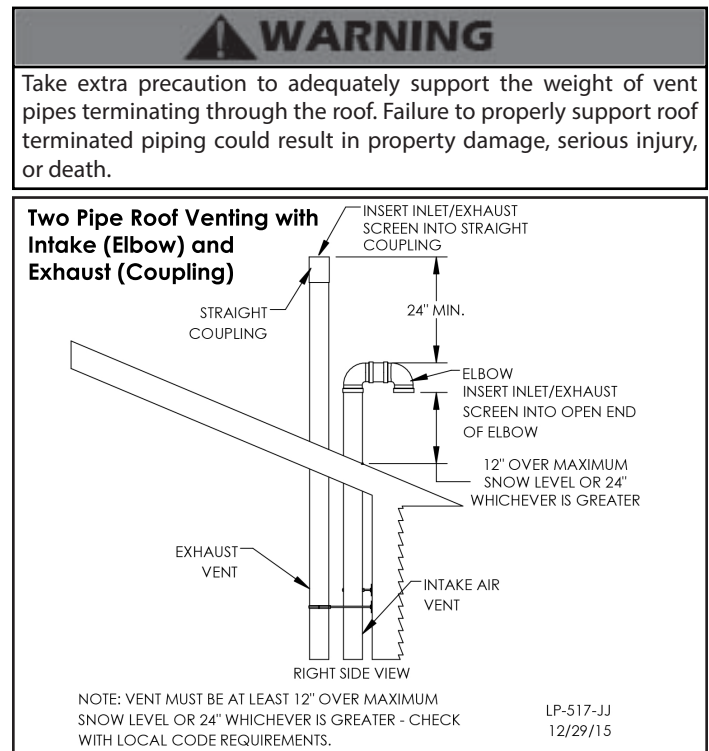

Figure 15 - Two Pipe Roof Venting

NOTE: These drawings are meant to demonstrate system venting only. The installer is responsible for all equipment and detailing required by local codes.

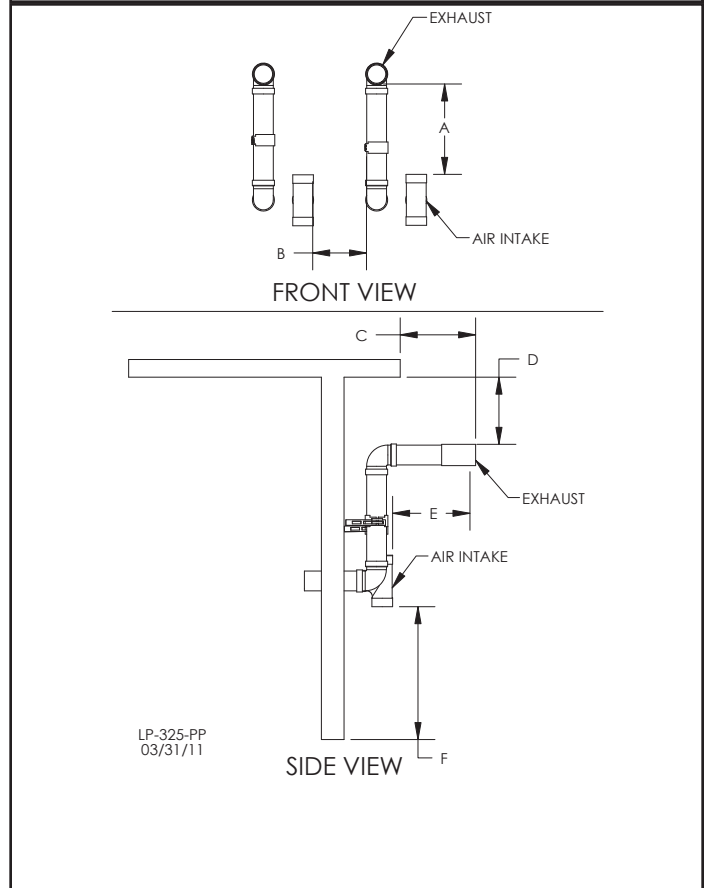
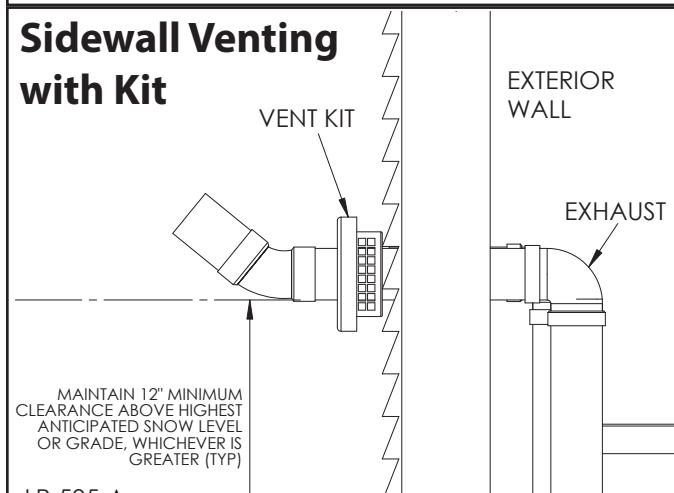
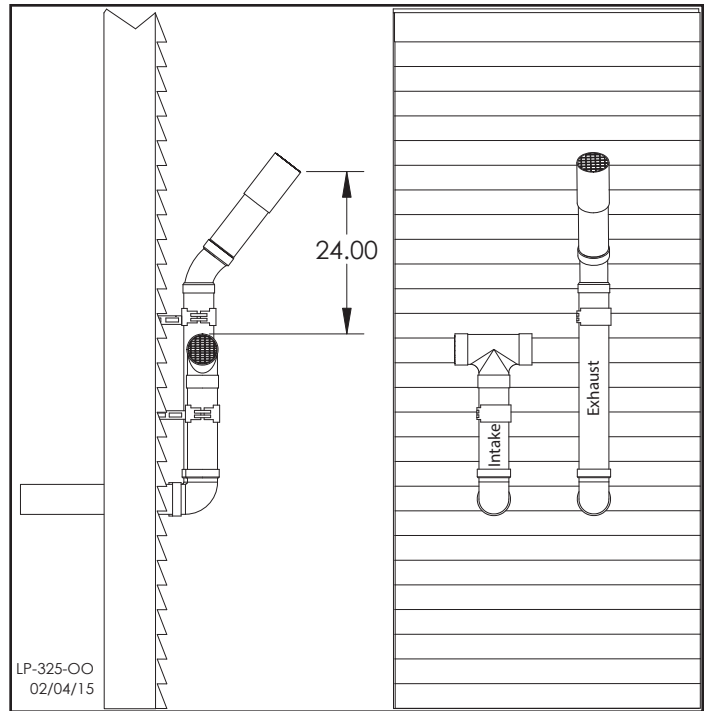
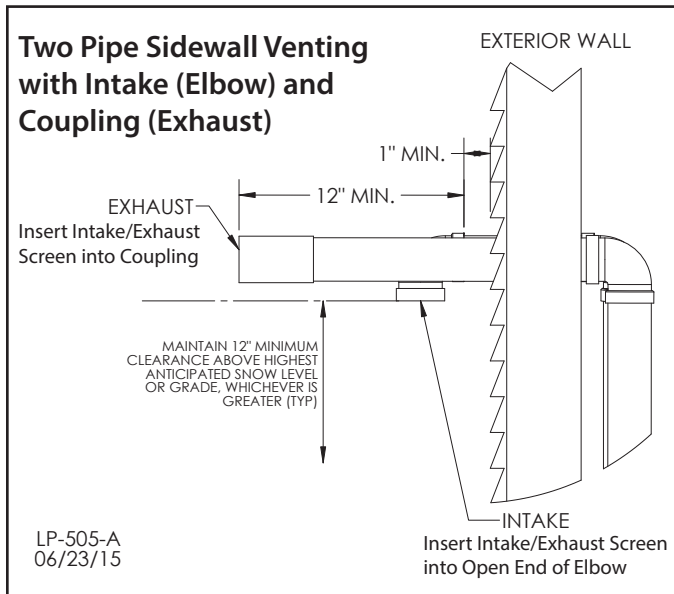

Figure 16 - Two Pipe Sidewall Venting and Sidewall Venting with Optional Kit (NOT INCLUDED WITH THE BOILER)

NOTE: These drawings are meant to demonstrate system venting only. The installer is responsible for all equipment and detailing required by local codes.

WARNING

All vent pipes must be glued, properly supported, and the exhaust pitched a minimum of 1/4" per foot back to the boiler to allow drainage of condensate. When placing support brackets on vent piping, the first bracket must be within 1 foot of the boiler and the balance of 4 foot intervals on the vent pipe. Venting must be readily accessible for visual inspection from the first three feet from the boiler.

Figure 17 - Horizontal (Snorkel) Venting

NOTES:

- A. For every 1" of overhang, the exhaust vent must be located 1" vertical below overhang (overhang means top of building structure and not two adjacent walls [corner of building]).
- B. Typical installations require 12" minimum separation between bottom of exhaust outlet and top of air intake.
- C. Maintain 12" minimum clearance above highest anticipated snow level or grade (whichever is greater).
- D. Minimum 12" between vents when installing multiple vents.
- E. 12" minimum beyond air intake.

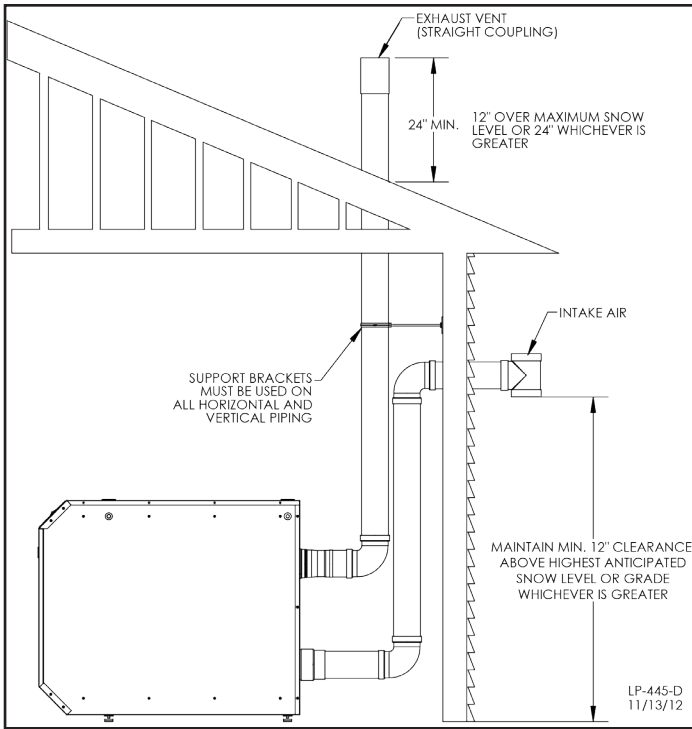

Figure 18 - Unbalanced Venting - Roof Exhaust and Sidewall Intake

NOTE: These drawings are meant to demonstrate system venting only. The installer is responsible for all equipment and detailing required by local codes.

WARNING
All vent pipes must be glued, properly supported, and the exhaust pitched a minimum of 1/4" per foot back to the boiler to allow drainage of condensate. When placing support brackets on vent piping, the first bracket must be within 1 foot of the boiler and the balance of 4 foot intervals on the vent pipe. Venting must be readily accessible for visual inspection from the first three feet from the boiler.
An unbalanced vent system can be installed ONLY when the exhaust is in the vertical position. Failure to do so could result in serious personal injury or death.
Take extra precaution to adequately support the weight of vent pipes terminating through the roof. Failure to properly support roof terminated vent piping could result in property damage, serious personal injury, or death due to flue gas leakage.

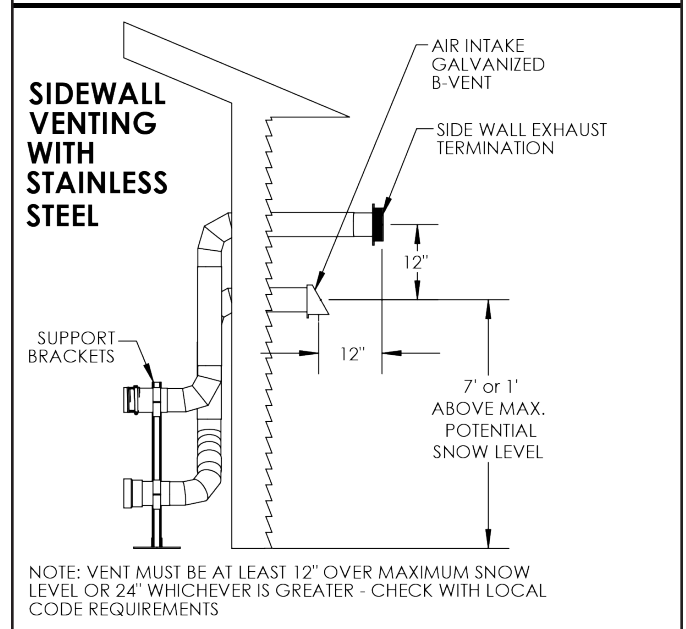
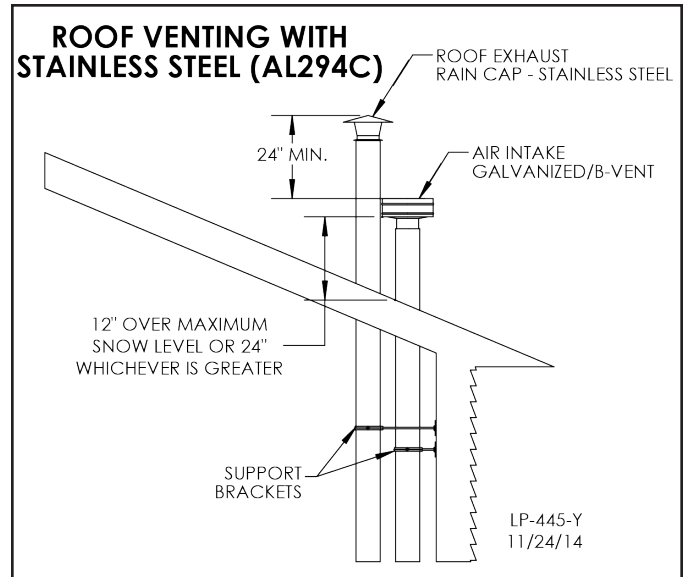

Figure 19 - Roof and Sidewall Venting with Stainless Steel

WARNING	
Breathing Hazard - Carbon Monoxide Gas	
	<ul style="list-style-type: none"> Do not operate heater if flood damaged. Install vent system in accordance with local codes and manufacturers installation instructions. Do not obstruct heater air intake or exhaust. Support all vent piping per manufacturers installation instructions. Do not place chemical vapor emitting products near unit. According to NFPA 720, carbon monoxide detectors should be installed outside each sleeping area. Never operate the heater unless it is vented to the outdoors. Analyze the entire vent system to make sure that condensate will not become trapped in a section of vent pipe and therefore reduce the open cross sectional area of the vent.
	<p>Breathing carbon monoxide can cause brain damage or death. Always read and understand instruction manual.</p>
LP-304	

2. Room and Indoor Combustion Ventilation Requirements

When using an indoor combustion air installation, the mechanical room **MUST** be provided with properly sized openings, and/or be of sufficient volume to assure adequate combustion air and proper ventilation for all gas fired appliances in the mechanical room to assure adequate combustion air and proper ventilation. The requirements shown here are for the boiler only. Additional gas fired appliances in the mechanical room will require an increase in the net free area and/or volume to supply adequate combustion air for all appliances. This must be done in accordance with the National Fuel Gas Code, NFPA 54 / ANSI Z223.1.

This boiler can be vented using mechanical room air only for combustion. No combustion air openings are needed when the boiler is installed in a space with a volume **NO LESS** than 50 cubic feet per 1,000 BTU/hr of all installed gas fired appliances and the building **MUST NOT BE** of "Tight Construction".

TIGHT CONSTRUCTION: A building with less than .4 ACH (air changes per hour). For buildings of "Tight Construction", provide air openings into the building from the outside.

Indoor and outdoor combustion air may be combined by applying a ratio of available volume to required volume times the required outdoor air opening(s) size(s). This must be done in accordance with the National Fuel Gas Code, NFPA 54 / ANSI Z223.1.

1. If air is taken directly from outside the building with no duct, provide two permanent openings to the mechanical room each with a net free area of one square inch per 4000 BTU/hr input. See Figure 20.
2. If combustion and ventilation air is taken from the outdoors using a duct to deliver the air to the mechanical room, each of the two openings should be sized based on a minimum free area of one square inch per 2000 BTU/hr input. See Figure 21.
3. If air is taken from another interior space combined with the mechanical room:
 - a. Two spaces on same story: Each of the two openings specified should have a net free area of one square inch for each 1000 BTU/hr input, but not less than 100 square inches.
 - b. Two spaces on different stories: One or more openings should have a net free area of two square inches per 1000 BTU/hr.

See Figure 22 for reference.

4. If a single combustion air opening is provided to bring combustion air in directly from the outdoors, the opening must be sized based on a minimum free area of one square inch per 3000 BTU/hr. This opening must be located within 12" of the top of the enclosure. See Figure 23.
- Combustion air requirements are based on the latest edition of the National Fuel Gas Code, NFPA 54 / ANSI Z223.1, CGA Standard CAN/CSA B149.1 in Canada. Check all local code requirements for combustion air.

All dimensions based on net free area in square inches. Metal louvers or screens reduce the free area of a combustion air opening a minimum of approximately 25%. Check with louver manufacturers for exact net free area of louvers.

Where two openings are provided, one must be within 12" of the ceiling, and one must be within 12" of the floor of the mechanical room. Each opening must have a net free area as specified in Table 17. Single openings shall commence within 12" of the ceiling. The minimum dimension of air openings should not be less than 3".

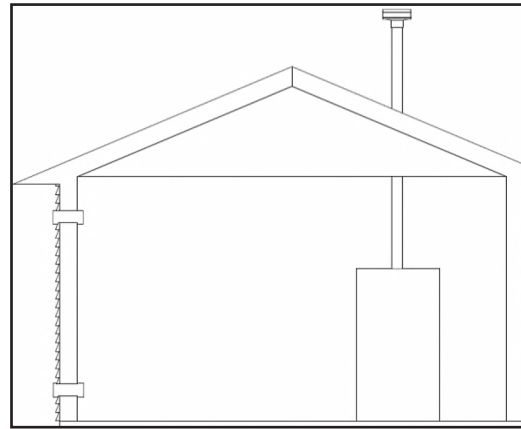

Figure 20 - Combustion Air from Outdoors

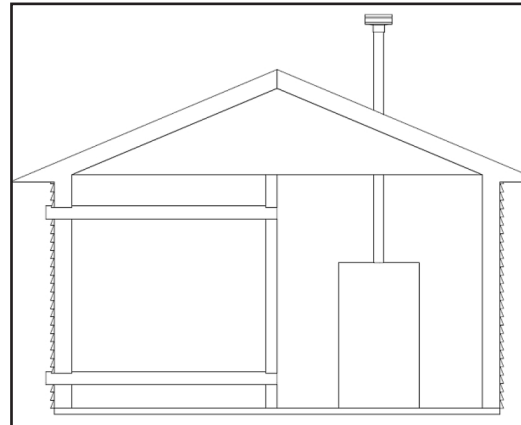

Figure 21 - Combustion Air through Ductwork

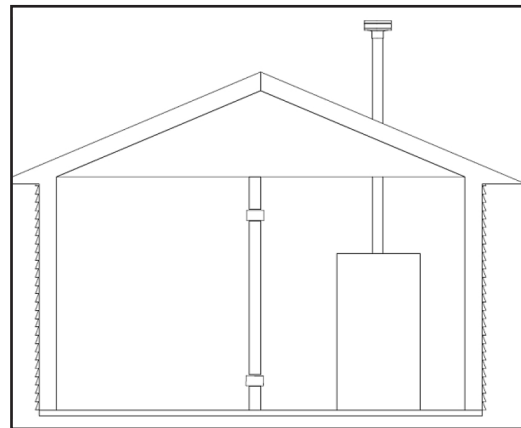

Figure 22 - Combustion Air from Indoors

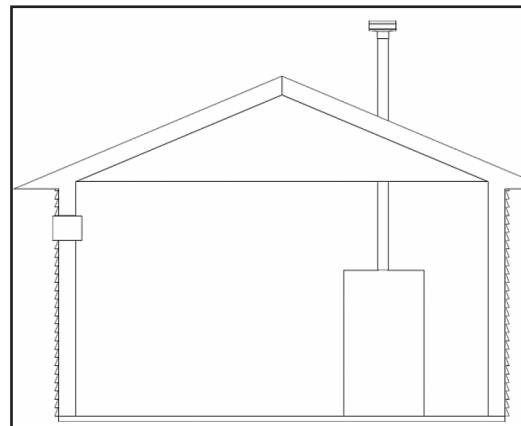

Figure 23 - Combustion Air from Outdoors - Single Opening

CAUTION

Under no circumstances should the mechanical room ever be under negative pressure. Particular care should be taken where exhaust fans, attic fans, clothes dryers, compressors, air handling units, etc., may take away air from the unit. Failure to follow these instructions could result in property damage or personal injury.

Combustion air supply must be completely free of any flammable vapors that may ignite, or chemical fumes which may be corrosive to the boiler. See Table 4 for a list of combustion air contaminants. These chemicals, when burned, form acids which quickly attack the stainless steel heat exchanger, headers, flue connectors, and the vent system. The result is improper combustion and premature boiler failure. Such failure IS NOT covered under warranty.

EXHAUST FANS: Any fan or appliance which exhausts air from the mechanical room may deplete the combustion air supply and/or cause a downdraft in the venting system. Spillage of flue products from the venting system into an occupied living space can cause a very hazardous condition that must be corrected immediately.

Minimum Recommended Combustion Air Supply to Mechanical Room				
Model	Figure 20		Figure 21	
	*Outside Air from 2 Openings Directly from Outdoors ¹		*Outside Air from 2 Ducts Delivered from Outdoors ¹	
	Top Opening, in ²	Bottom Opening, in ²	Top Opening, in ²	Bottom Opening, in ²
500	125	125	250	250
700	175	175	350	350
850	215	215	425	425
Model	Figure 22			Figure 23
	Inside Air from 2 Ducts Delivered from Interior Space ²			*Outside Air from 1 Opening Directly from Outdoors, in ² ¹
	Same Story		Different Stories	
	Top Opening, in ²	Bottom Opening, in ²	Top Opening, in ²	
500	500	500	1000	170
700	700	700	1400	235
850	850	850	1700	285

Table 17 - Indoor Combustion Air Sizing

The above requirements are for the boiler only; additional gas fired appliances in the mechanical room will require an increase in the net free area and/or volume to supply adequate combustion air for all appliances.

No combustion air openings are needed when the boiler is installed in a space with a volume NO LESS than 50 cubic feet per 1,000 BTU/hr of all installed gas fired appliances. Buildings MUST NOT be of *Tight Construction*.

¹Outside air openings shall communicate with the outdoors.
²Combined interior space must be 50 cubic feet per 1,000 BTU/hr input. Buildings MUST NOT be of *Tight Construction*.

Part 6 - Condensate Removal

NOTE: Check with your local gas company to determine if combustion condensate disposal is permitted in your area. In the state of Massachusetts, condensate must be neutralized before entering a drain.

This boiler is a high efficiency appliance, and therefore produces condensate: a by-product of the combustion process. A condensate collection system with an internal float switch monitors condensate level to prevent it from backing up into the combustion system. There is a 3/4" socket connection provided to connect the outlet of the collection system to a drain or condensate pump.

Condensate from the boiler is slightly acidic with a pH of 3.2 - 4.5. To avoid long term damage to the drainage system and to meet local code requirements, HTP recommends neutralizing condensate with a Condensate Neutralizer Kit (Part # 7350P-611). The neutralizer kit connects to the drain system and contains limestone chips that neutralize the pH level of the condensate. The neutralizer kit should be checked annually and the limestone chips replenished if necessary. When replacing the limestone chips, take care to ensure chips are no smaller than 1/2" to avoid blockage in condensate piping (refer to figure below for piping of the condensate neutralizer.)

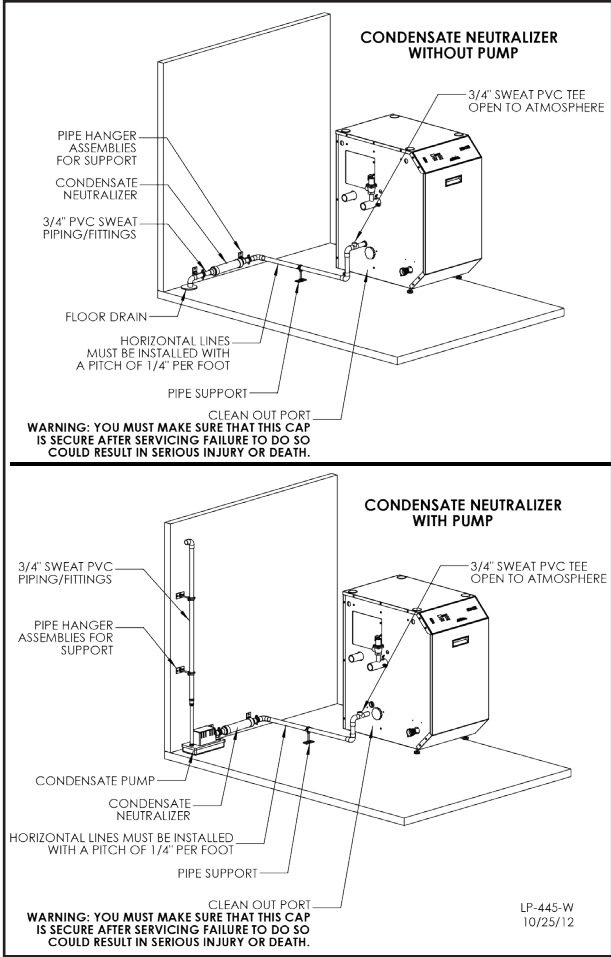

Figure 24 - Condensate Piping

NOTES:

1. Condensate line must be pitched at least 1/4" per foot to properly drain. If this cannot be done, or a very long length of condensate hose is used, increase the condensate line to a minimum of 1" ID and place a tee in the line after the condensate neutralizer to properly reduce vacuum lock in the drain line.
2. PVC or CPVC pipe should be the only material used for condensate line. Steel, brass, copper, and other metals will be subject to corrosion or deterioration.
3. A frozen condensate line could result in a blocked vent condition.

It is very important to protect the condensate line from freezing temperatures or any type of blockage. In installations that may encounter sustained freezing conditions, the use of heat tape is recommended to avoid freezing of the condensate line. It is also recommended to bush up the condensate line size to 1" and terminate condensate discharge as close to the unit as possible. Longer condensate runs are more prone to freezing. Damages due to frozen or blocked condensate lines ARE NOT covered by warranty.

4. Support of the condensate line may be necessary to avoid blockage of the condensate flow.

5. To allow proper drainage on longer horizontal condensate runs, tubing size may need to increase to 1" and a second line vent may be required.

NOTE: To clean out condensate trap, see Maintenance section.

CAUTION
The condensate line must remain unobstructed. If allowed to freeze in the line or obstructed in any other manner, condensate can exit from the boiler tee, resulting in potential water damage to property. When installing a condensate pump, select one approved for use with condensing boilers and furnaces. The condensate pump should have an overflow switch to prevent property damage from spillage. Condensate from the boiler will be slightly acidic (pH from 3.2 to 4.5). Install a neutralizing filter if required by local codes.
It is very important that condensate piping be no smaller than 3/4". Use a tee at the condensate connection with a branch vertically up and open to the atmosphere to prevent a vacuum that could obstruct the flow of condensate from the boiler. To prevent sagging and maintain pitch, condensate piping should be supported with pipe supports.
When installing a condensate pump, select one approved for use with condensing boilers and furnaces. The pump should have an overflow switch to prevent property damage from condensate spillage.
WARNING
Power to the optional condensate pump is continuous. When the boiler is powered off the condensate pump will remain on. It is important to remember to turn off the condensate pump when powering down the boiler. Failure to do so could result in property damage, severe personal injury, or death.

Part 7 - Wiring

WARNING
To avoid electrical shock, turn off all power to the boiler prior to opening an electrical box within the unit. Ensure the power remains off while any wiring connections are being made. Failure to follow these instructions could result in component or product failure, serious injury, or death. Such product failure IS NOT covered by warranty.
Jumping out control circuits or components WILL VOID product warranty and can result in property damage, personal injury, or death.
Electrical Shock Hazard - Turn off electrical power supply at service entrance panel before making any electrical connections. Failure to follow do do so could result in serious injury, or death.
It is of extreme importance that this unit be properly grounded. It is very important that the building system ground is inspected by a qualified electrician prior to making this connection. Electrical power must only be turned on when the boiler is completely filled with cold water. Failure to follow these instructions could result in component or product failure, serious injury, or death.

CAUTION
Label all wires prior to disconnecting them when servicing the boiler. Wiring errors can cause improper and dangerous operation. Failure to follow these instructions may result in property damage or personal injury.
CAUTION
Wiring must be NEC Class 1. If original wiring supplied with the boiler must be replaced, use only TEW 105 °C wire or equivalent. Boiler must be electrically grounded as required by the National Electrical Code, ANSI/NFPA 70 - Latest Edition.
Each boiler controller can pull a maximum of 6.3 amps at 120V. It is recommended to wire each boiler to a dedicated minimum 15 amp circuit.

A. Installation Must Comply With

1. National Electrical Code and any other national, state, provincial, or local codes or regulations.
2. In Canada, CSA C22.1, Canadian Electrical Code Part 1, and any local codes.

B. Field Wiring Terminations

All connections made to the boiler in the field are done inside the electrical junction box located on the left side of the unit. Multiple knockout locations are available to route field wires into and out of the electrical junction box.

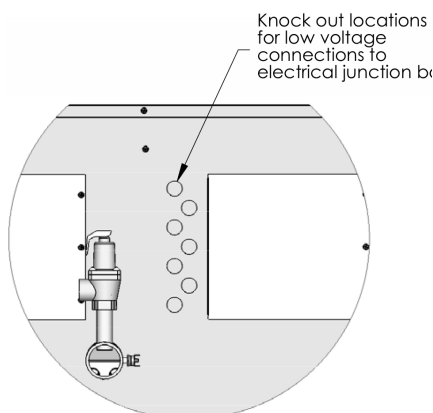

Figure 25 - Knockout Locations

C. Field Wiring

CAUTION
Check water chemistry section for acceptable levels. If water chemistry is acceptable, pumps may be wired directly to pump terminals. If water chemistry levels are too high, you must wire pumps to line voltage to run continuously to prevent lime buildup.

Pumps

The Mod Con VWH application requires a circulator pump for each boiler. Circulator pumps can be wired directly to the controller as shown in Figure 26 or wired directly to line voltage for continuous operation. Only wire the circulator pump to the controller if a tank sensor or mechanical control can be mounted to the storage tank, otherwise circulator pumps must be wired to run continuously. The circulator pump wired to the boiler control will have a default program of a 5 minute post purge to provide stabilization and post cleaning of the heat exchanger. The boiler control is capable of supplying 120 volts at up to 3 amps to run the circulator pump. If using a larger circulator pump requiring more than 3 amps or higher voltage, an external motor starter, sized appropriately for the pump motor, must be used. This starter should have a 120 VAC coil. If a starter with a 120 VAC coil is used, it can be wired directly to the appropriate pump terminals as shown in Figure 26.

Tank and Sensor Connections

When the Mod Con VWH is used in a single tank installation, it is recommended to use a sensor (7250P-325) placed in a well in the storage tank for best temperature control. If multiple tanks are used in the installation, it is recommended to put a mechanical aquastat in each tank and wire them in series to provide temperature control

of the tanks. (See Applications for reference.) The control in the Mod Con VWH will read either the temperature of the tank sensor or the status of the aquastats, and cause the boiler to run until the water temperature of the tank(s) meets the desired set point.

If a sensor or aquastat cannot be placed directly in the tank, then one sensor should be used on the pipe carrying water from the tank(s) to the boiler. To minimize temperature loss in the piping, this sensor should be placed as close to the tank(s) as possible. The use of a pipe sensor will be somewhat less accurate than using a sensor in the tank, and has the disadvantage of requiring the boiler pump(s) to run continuously so the sensor is always measuring the tank water temperature.

In a multiple Mod Con VWH installation, where the boilers are connected for cascade operation, a system sensor is needed in addition to the tank or pipe sensor described above. The system sensor is mounted on the common pipe to the tank(s) from the boilers as close to the tank(s) as possible. The purpose of this sensor is to serve as feedback to the control and provide it with the aggregate temperature of all firing boilers. The master boiler control will then fire the boilers in cascade sequence to maintain the water temperature in this pipe and provide correct tank heating.

The electrical junction box has separate, clearly marked terminal strips for line voltage and low voltage wiring. Special jacks are provided for trouble-free cascade system wiring using standard CAT3 or CAT5 patch cables.

D. Line Voltage Wiring for Standard Boiler

NOTE: A termination plug is included in the CAT 3 / CAT 5 Bus Connection Point, labeled J3 in Figure 26. DO NOT REMOVE THIS PLUG! Doing so will affect boiler operation and void warranty.

1. Connect the incoming power wiring to the line voltage terminal strip in the electrical junction box at terminals 120V, Neutral, Ground (shown in Figure 26).
2. A line voltage fused disconnect switch may be required, externally mounted and connected according to local codes that may apply.
3. If the pump used for the boiler operates at 120 volts and less than 3 amps is required, it may be connected directly to the terminals marked BOILER HOT, BOILER NEUT, and BOILER GRD. If the pump operates at a voltage other than 120 volts and/or requires more than 3 amps, an external motor starter must be used to operate the pump. If the starter is equipped with a 120 volt coil, the coil connections may be connected directly to the terminals marked BOILER HOT and BOILER NEUT. Refer to Figure 29 for a representative drawing of this configuration. If a motor starter is used, it should be selected, installed, and wired in compliance with all local electrical codes and requirements. In the absence of such codes or requirements, the National Electrical Code (NFPA 70) should be followed.

E. Alarm Connections

The control includes a dry contact alarm output. This is an SPDT circuit, rated at 5 amps at 120 volts. This contact can be used to activate an alarm light or bell or notify a building management system if the boiler goes into a lockout condition. The circuit between the ALARM COM and NC terminals is closed during normal operation and the circuit between ALARM COM and NO is open during normal operation. The connections depicted in Figure 26 show two 120 volt lights connected to the alarm terminals. One light will be on when the boiler is in normal mode and the other light will be on when the boiler is in lockout mode.

F. Low Voltage Connections for Standard Boiler

1. All low voltage cables should enter the electrical junction box through the provided knock out holes as shown in Figure 25.
2. Connect all low voltage field devices to the low voltage terminal strip located in the electrical junction box.

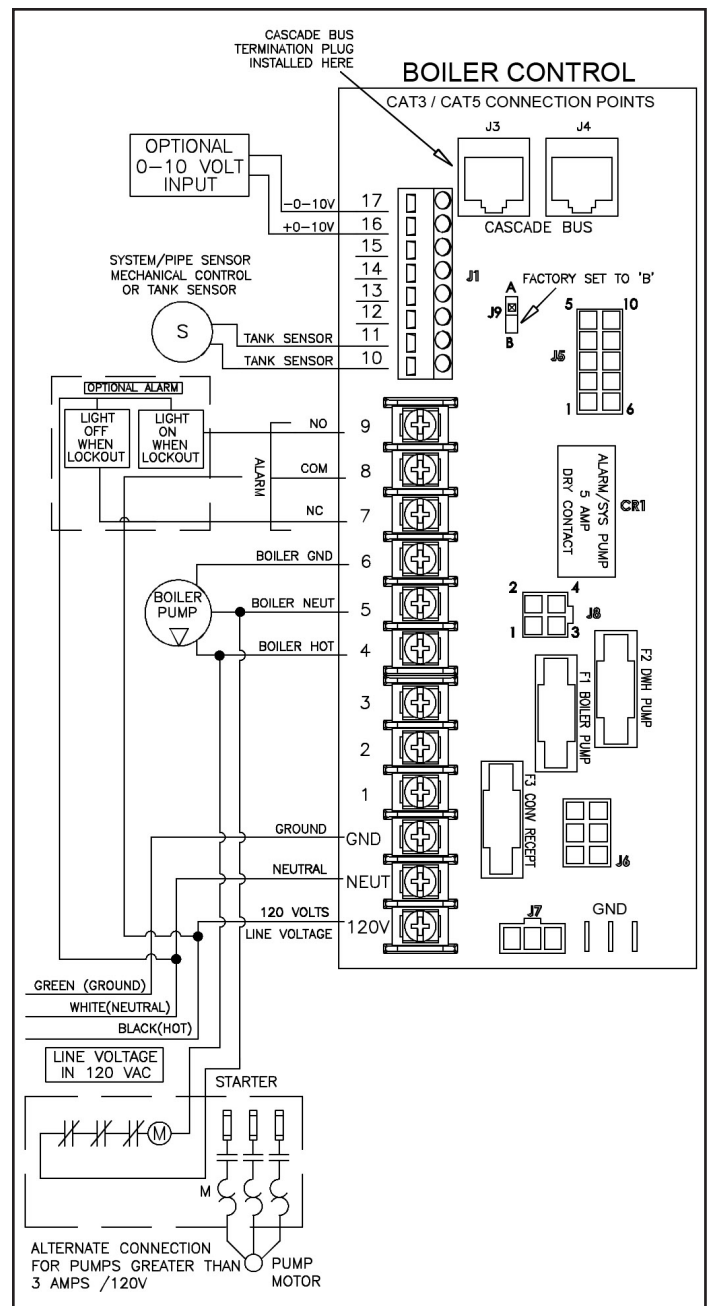

Figure 26 - VWH Control Wiring

G. Tank Sensor or Mechanical Control

Connect the tank sensor or mechanical controls to the TANK SENSOR terminals (10, 11) of the low voltage terminal strip as shown in Figure 26. The control will automatically determine which type of sensor is connected and operate accordingly.

WARNING

Failure to use the correct sensor may result in tank temperature being either above or below set point, and could result in decreased performance, substantial property damage, or heightened risk of injury or death due to scalds.

Caution should be used to ensure neither of these terminals becomes connected to ground.

NOTE: If sensor wires are located in an area with sources of potential electromagnetic interference (EMI), the sensor wires should be shielded, or the wires routed in a grounded metal conduit. If using shielded cable, the shielding should be connected to the common ground of the boiler.

H. System / Pipe Sensor

The system/pipe sensor can be used to control the temperature of the storage tank when a tank sensor or mechanical control cannot be mounted. The system/pipe sensor would be wired into the terminals of the low voltage terminal strip as shown on Figure 26. It is important to note that when a system/pipe sensor is used, the circulating pump must be wired to operate continuously; otherwise the boiler will short cycle.

The system/pipe sensor can also be used in a cascade system when the sensor is placed on the supply line of multiple boilers that feed the storage tank. This will control the temperature and modulate the firing rate of the connected boilers. The system/pipe sensor would then be wired into the master boiler terminals on the low voltage strip as shown on Figure 29.

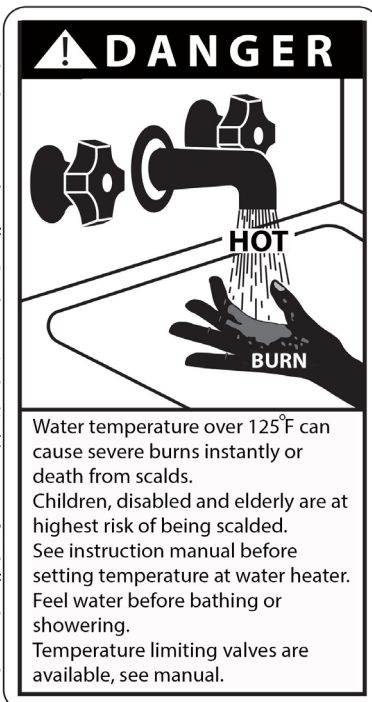

I. Optional 0-10 Volt Building Control Signal

1. A signal from a building management system may be connected to the boiler to enable remote control. This signal should be a 0-10 volt positive-going DC signal. When this input is enabled using the installer menu, a building control system can be used to control the set point temperature of the boiler. The control interprets the 0-10 volt signal as follows; when the signal is between 0 and 1.5 volts, the boiler will be in standby mode, not firing. When the signal rises above 1.5 volts, the boiler will ignite. As the signal continues to rise towards its maximum of 10 volts, the boiler will increase in set point temperature. See Part 10 for details on the setting of function 16.

2. Connect a building management system or other auxiliary control signal to the terminals marked 16, 0-10 VOLT + and 17, 0-10 VOLT – in the electrical junction box (shown in Figure 26). Caution should be used to ensure that the 0-10 VOLT + connection does not become connected to ground.

J. Optional High Gas Pressure Switch

1. If an optional high gas pressure switch is used, it should be installed on the outlet side of the gas valve. This is normally closed and will open if the pressure goes above 1.5" w.c. on the outlet side.

2. Locate the two pigtailed hanging from the electrical box inside of the boiler cabinet. Remove and discard the jumper plug from one of the unused pigtailed.

3. Connect the high gas pressure switch to the pigtail that you removed the jumper plug from.

K. Optional Low Gas Pressure Switch

1. If an optional low gas pressure switch is used, it should be installed on the inlet side of the gas valve. This is normally closed and will open if the pressure goes below 1" w.c. on the inlet side.

2. Locate the two pigtailed hanging from the electrical box inside of the boiler cabinet. Remove and discard the jumper plug from one of the unused pigtailed.

3. Connect the low gas pressure switch to the pigtail that you removed the jumper plug from.

L. Flow Switch

This VWH boiler requires the use of a flow switch. The flow switch kit comes packaged with detailed installation instructions which should be read and followed to ensure a functional system.

M. Wiring of Cascade System Communication Bus

1. A Cascade Bus Termination Plug has been installed on the customer connection board of this boiler. The purpose of this plug is to stabilize communication between multiple boilers and reduce electrical "noise". See Figures 27 and 28 for Cascade Bus Termination Plug installation detail.

NOTE: It is important that the termination plug in multiple boilers (cascaded units) be installed as depicted in Figure 28. Leave the plug installed in the J3 port on the Master boiler. Remove the plug on intermediate Follower boilers. Move the plug to the J4 port on the final Follower boiler.

2. Use standard CAT3 or CAT5 computer network patch cables to connect the communication bus between each of the boilers. These cables are readily available at any office supply, computer, electronic, department or discount home supply store in varying lengths. If you possess the skills you can also construct custom length cables.

3. It is recommended to use the shortest length cable that will reach between the boilers and create a neat installation. Do not run unprotected cables across the floor where they may become wet or damaged. Avoid running communication cables parallel and close to or against high voltage (120 volt or greater) wiring. HTP recommends that the maximum length of communication bus cables not exceed 200 feet.

4. Route the communication cables through one of the knockouts in the cabinet.

5. Connect the boilers in a daisy chain configuration as shown below. It is best to wire the boilers using the shortest wire runs rather than trying to wire them in the order that they are addressed. The communication bus jacks on the customer connection panel are interchangeable so you can use either one or both in any order to connect the cable.

If you have connected the boilers to each other properly, there will be no open communication connection ports.

N. Cascade Master Pump and Sensor Wiring

1. Place the cascade master overlay sticker onto the field connection board of the boiler designated as the cascade master.

2. If it is desired to have the boiler control the boiler pump, connect the boiler pump to the BOILER HOT, BOILER NEUT, and BOILER GND terminals.

3. Connect the system sensor to the terminals marked SYS SENSOR.

4. Do not connect anything to the OUTDOOR SENS or THERMOSTAT terminals.

5. If 0-10 volt positive going DC signal input is used, connect to marked terminals.

O. Cascade Follower Pump and Sensor Wiring

1. Connect the boiler pump to the terminals labeled 1 (HOT), 2 (NEUT), and 3 (GND).

2. An alarm bell or light can be connected to the alarm contacts of the follower boiler. The normally closed alarm contact may be used to turn a device off if the boiler goes into lockout mode. The alarm contacts are rated 5 amps at 120 VAC.

To connect an alarm device, connect the power for the device to the ALARM COM terminal. Connect the alarm device hot wire to the ALARM NO terminal. Connect the neutral or return of the alarm device to the neutral or return of the power for the alarm device.

To connect a device that should be powered off during a boiler lockout condition, follow the same instructions as above except use the ALARM NC terminal rather than the ALARM NO terminal.

Note that in a cascade system the alarm output of the boiler addressed as #1 will also be active if the master boiler has a lockout condition. The alarm output of boilers addressed as 2-7 will only activate an alarm if a lockout condition occurs on that specific boiler.

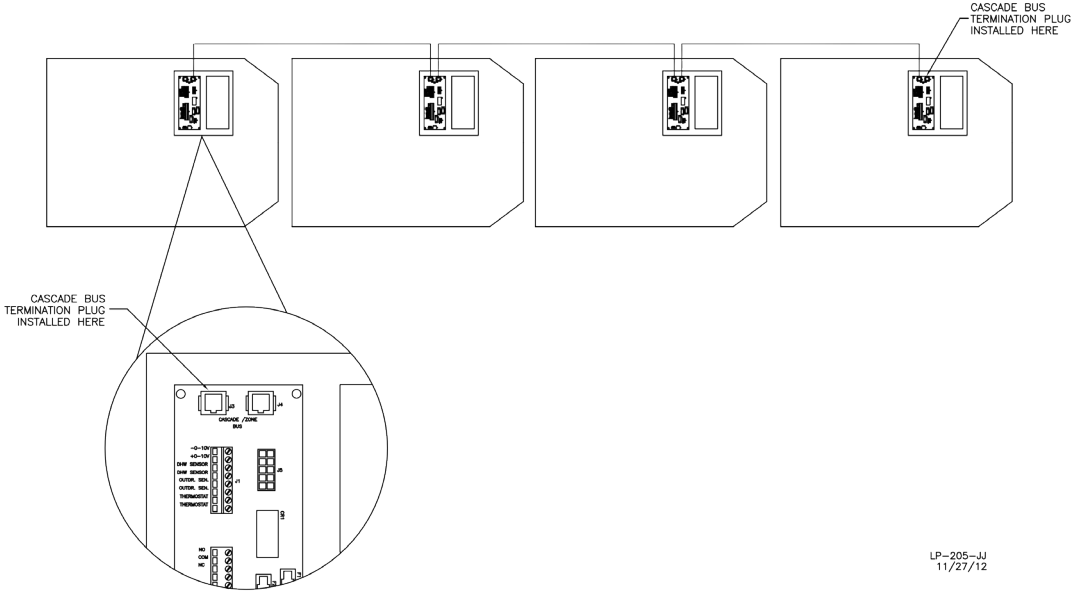

LP-205-JJ
11/27/12

Figure 27 - Wiring Cascade System

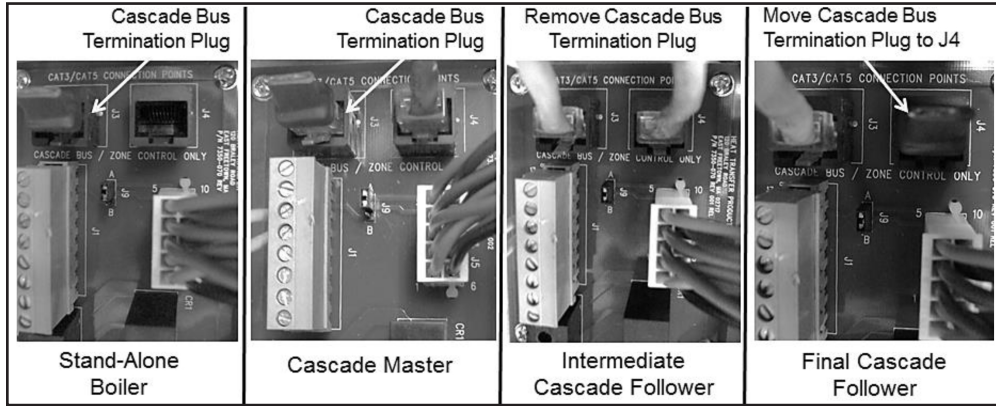

Figure 28 - Cascade Termination Plug Detail

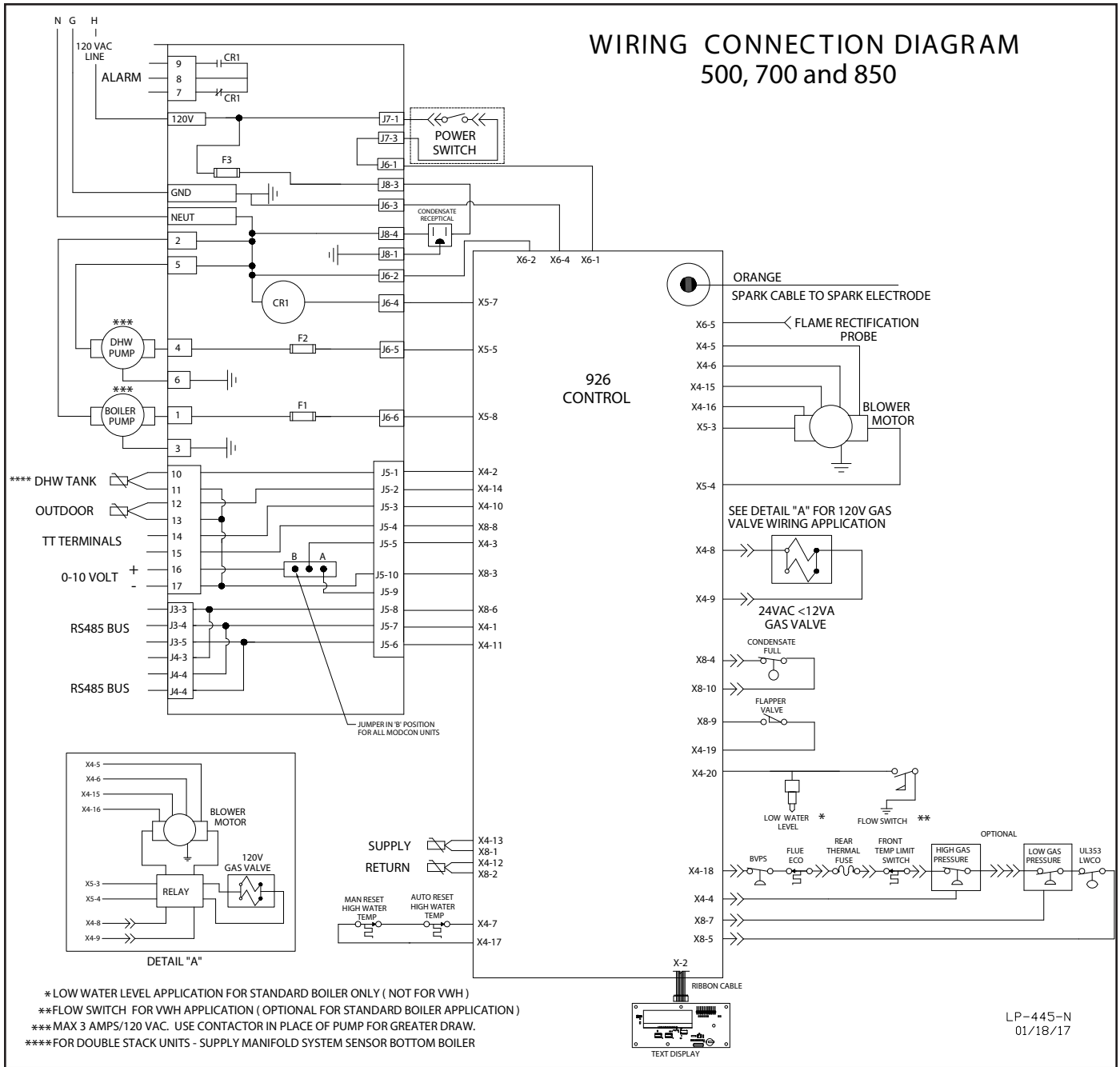

Figure 30 - Internal Connection Diagram

Part 8 - Gas Connections



WARNING

Failure to follow all precautions could result in fire, explosion, severe injury, or death.

It is very important that you are connected to the type of gas noted on the rating plate. "LP" for liquefied petroleum, propane gas, or "NG" for natural or city gas. Do not do a gas conversion without an approved gas conversion kit. Prior to turning the gas on, all gas connections must be approved by the local gas supplier or utility, in addition to the governing authority.

A gas conversion kit comes with 500 model boilers ONLY. Field conversions ARE NOT ALLOWED on the 700/850 models. A properly calibrated combustion analyzer must be used to verify proper combustion. Failure to follow the above instructions could result in property damage, serious injury, or death.

The gas supply shall have a minimum of no less than 3.5" water column, a maximum inlet pressure of no greater than 14" water column (350 mm), and ½ pound pressure (3.5 kPa). The entire piping system, gas meter, and regulator must be sized properly to prevent excessive pressure drop (greater than 0.5" WC) as stated in the National Fuel Gas Code. This information is listed on the rating plate.



WARNING

UL recognized fuel gas detectors are recommended in all enclosed propane and natural gas applications where there is a potential for an explosive mixture of fuel gas to accumulate. The installation of these detectors should be made in accordance with the detector manufacturer's recommendations, and/or local laws. Failure to install fuel gas detectors in these applications could result in fire, explosion, property damage, severe personal injury, or death.

The gas connection on the boiler is 1 1/2" for the 500 model and 2" for the 700/850 models. It is mandatory that this fitting is used for connection to a field fabricated drip leg as shown in the illustration per the National Fuel Gas Code. You must ensure that the entire gas line to the connection at the boiler is no smaller than the unit supplied connection.

Once all inspections have been performed, the piping must be leak tested. If the leak test requirement is a higher test pressure than the maximum inlet pressure, you must isolate the boiler from the gas line. In order to do this, shut the gas off using factory and field-installed gas cocks. This will prevent high pressure. Failure to do so may damage the gas valve. In the event the gas valve is exposed to a pressure greater than 1/2 PSI, 14" w.c. (3.5 kPa), the gas valve must be replaced. Never use an open flame (match, lighter, etc.) to check gas connections.

A. Gas Piping

1. Run the gas supply line in accordance with all applicable codes.
2. Locate and install manual shutoff valves in accordance with state and local requirements.
3. In Canada, the Manual Shutoff must be identified by the installing contractor.
4. It is important to support gas piping as the unit is not designed to structurally support a large amount of weight.
5. Purge all gas lines thoroughly to avoid start up issues with air in the lines.
6. Sealing compound must be approved for gas connections. Care must be taken when applying compound to prevent blockage or obstruction of gas flow which may affect the operation of the unit.

WARNING

Support gas supply piping with hangers, not by the boiler or its accessories. The boiler gas valve and blower will not support the weight of the piping. Make sure the gas piping is protected from physical damage and freezing, where required. Failure to follow these instructions could result in gas leakage, and result in fire, explosion, property damage, severe personal injury, or death.

Do not use Teflon tape on gas line pipe thread. Use a pipe compound rated for use with natural and propane gases. Apply sparingly on male pipe ends, leaving the two end threads bare and flow unobstructed. Failure to follow these instructions could result in gas leakage or blockage, and result in fire, explosion, property damage, severe personal injury, or death.

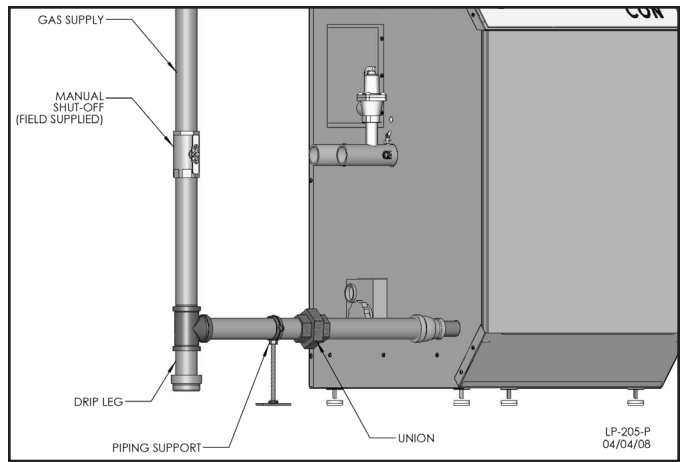

Figure 31 - Gas Connection

WARNING

Never use an open flame (match or lighter) to check for gas leaks. Use a soapy solution to test connection. Failure to use a soapy solution test or check gas connection for leaks can result in substantial property damage, severe personal injury, or death.

CAUTION

Use two wrenches when tightening gas piping at the boiler: One to prevent the boiler gas line from turning. Failure to prevent the boiler gas connection from turning could result in damage to the gas line components, substantial property damage, severe personal injury, or death.

CSA or UL listed flexible gas connections can be used when installing the boiler. Flexible gas connections have different capacities and must be sized correctly for the connected boiler firing rates. Consult with the flex line supplier to assure the line size is adequate for the job. Follow local codes for proper installation and service requirements.

B. Gas Table

Refer to Table 18 to size the supply piping to minimize pressure drop between the meter or regulator and unit. Maximum capacity of pipe in cubic feet of gas per hour for gas pressures of .5 w.c. or less and a pressure drop of .3 inch w.c.

Natural Gas Supply Piping Capacity Chart								
(0.6 Specific gravity gas; 0.5" WC pressure drop)								
*Schedule 40 iron pipe size in nominal inches								
Cubic Ft. Hr.	500	1000	1500	2000	2500	3000	3500	4000
Model	1 Boiler	2 Boilers	3 Boilers	4 Boilers	5 Boilers	6 Boilers	7 Boilers	8 Boilers
500 @ 100' of Pipe	1 1/2"	2"	2 1/2"	3"	3"	3"	4"	4"
500 @ 250' of Pipe	2"	2 1/2"	3"	3"	4"	4"	4"	4"
Cubic Ft. Hr.	700/850	1400/1700	2100/2550	2800/3400	3500/4250	4200/5100	4900/5950	5600/6800
Model	1 Boiler	2 Boilers	3 Boilers	4 Boilers	5 Boilers	6 Boilers	7 Boilers	8 Boilers
700/850 @ 100' of Pipe	2"	2 1/2"	3"	4"	4"	4"	4"	5"
700/850 @ 250' of Pipe	2 1/2"	3"	4"	4"	5"	5"	5"	5"

Table 18 - Gas Supply Piping Size Chart for Boilers

⚠ WARNING

Breathing Hazard - Carbon Monoxide Gas



- Do not operate heater if flood damaged.
- Install vent system in accordance with local codes and manufacturers installation instructions.
- Do not obstruct heater air intake or exhaust. Support all vent piping per manufacturers installation instructions.
- Do not place chemical vapor emitting products near unit.
- According to NFPA 720, carbon monoxide detectors should be installed outside each sleeping area.
- Never operate the heater unless it is vented to the outdoors.
- Analyze the entire vent system to make sure that condensate will not become trapped in a section of vent pipe and therefore reduce the open cross sectional area of the vent.

**Breathing carbon monoxide can cause brain damage or death.
Always read and understand instruction manual.**

LP-304

C. Check Inlet Gas Pressure

The gas valve is equipped with an inlet gas pressure tap that can be used to measure the gas pressure to the unit. To check gas pressure, perform the steps listed below:

1. **IMPORTANT!** Before you connect to the inlet pressure, shut off the gas and electrical power to unit.
2. Loosen the pressure tap with a small screwdriver. Refer to Figures 32 and 33 for location.
3. Each unit is equipped with a needle valve that will accept a 5/16 ID hose to connect to a digital manometer or liquid gauge to measure incoming pressure from 0-35" w.c.
4. Turn on the gas and power up the unit.
5. Put the unit into manual test mode (details on test mode in Part 10). In test mode, monitor pressure to assure it does not drop below 1 inch from its idle reading. If gas pressure is out of range or pressure drop is excessive, contact the gas utility, gas supplier, qualified installer, or service agency to determine correct action that is needed to provide proper gas pressure to the unit. If Gas Pressure is within normal range proceed to Step 6.
6. Exit test mode, then turn power off and shut off gas supply at the manual gas valve before disconnecting the hose from the gas monitoring device. Tighten screw on the pressure tap and turn gas on. Check for leaks with soapy solution. Bubbles will appear on the pipe to indicate a leak is present.

⚠ WARNING

Ensure the pressure tap screw is properly tightened to prevent gas leaks. Failure to do so could cause substantial property damage, severe personal injury, or death.

The gas piping must be sized for the proper flow and length of pipe to avoid pressure drop. The gas meter and regulator must be properly sized for the total gas load. If you experience a pressure drop greater than 1" w.c. (.87 kPa), the meter, regulator or gas line may be undersized or in need of service. You can attach a manometer to the incoming gas drip leg after removing the cap. The gas pressure must remain between 3.5" (.87 kPa) and 14" (3.5 kPa) during stand-by (static) mode and while in operating (dynamic) mode.

If an in-line regulator is used, it must be a minimum of 10 feet from the boiler. It is very important that the gas line is properly purged by the gas supplier or utility. Failure to properly purge the lines, or improper line sizing, will result in ignition failure. This problem

is especially noticeable in NEW LP installations and empty tank situations. This situation can also occur when a utility company shuts off service to an area to provide maintenance to their lines. This gas valve must not be replaced with a conventional gas valve under any circumstances.

⚠ WARNING

DO NOT adjust or attempt to measure gas valve outlet pressure. The gas valve is factory-set for the correct outlet pressure and requires no field adjustment. Attempts by the installer to adjust or measure the gas valve outlet pressure could result in damage to the valve and cause substantial property damage, severe personal injury, or death.

Natural or LP Gas	
Minimum Pressure	3.5"WC
Maximum Pressure	14"WC

Table 19 - Gas Pressure Requirements

NOTICE

Do not fire (operate) the boiler until all connections have been completed and the heat exchanger is filled with water. Doing so will damage the boiler and void the warranty.

⚠ DANGER

Do not do a gas conversion on this boiler without an officially approved conversion kit and instructions supplied by HTP. Failure to use a conversion kit when converting the boiler to fire on Natural or Propane gas will result in extremely dangerous burner operation, leading to fire, explosion, severe personal injury, or death.

⚠ WARNING

Strain on the gas valve and fittings may result in vibration, premature component failure and gas leakage, and result in fire, explosion, property damage, severe personal injury, or death.

Adjustments to the throttle screw or offset may only be made by a qualified gas technician using a calibrated combustion analyzer capable of measuring CO₂ and CO. Failure to follow this instruction could result in fire, explosion, property damage, severe personal injury, or death.

Ensure that the high gas pressure regulator is as least 6 – 10 feet upstream of the appliance. Failure to do so could result in substantial property damage, severe personal injury, or death.

D. Boiler Gas Valve

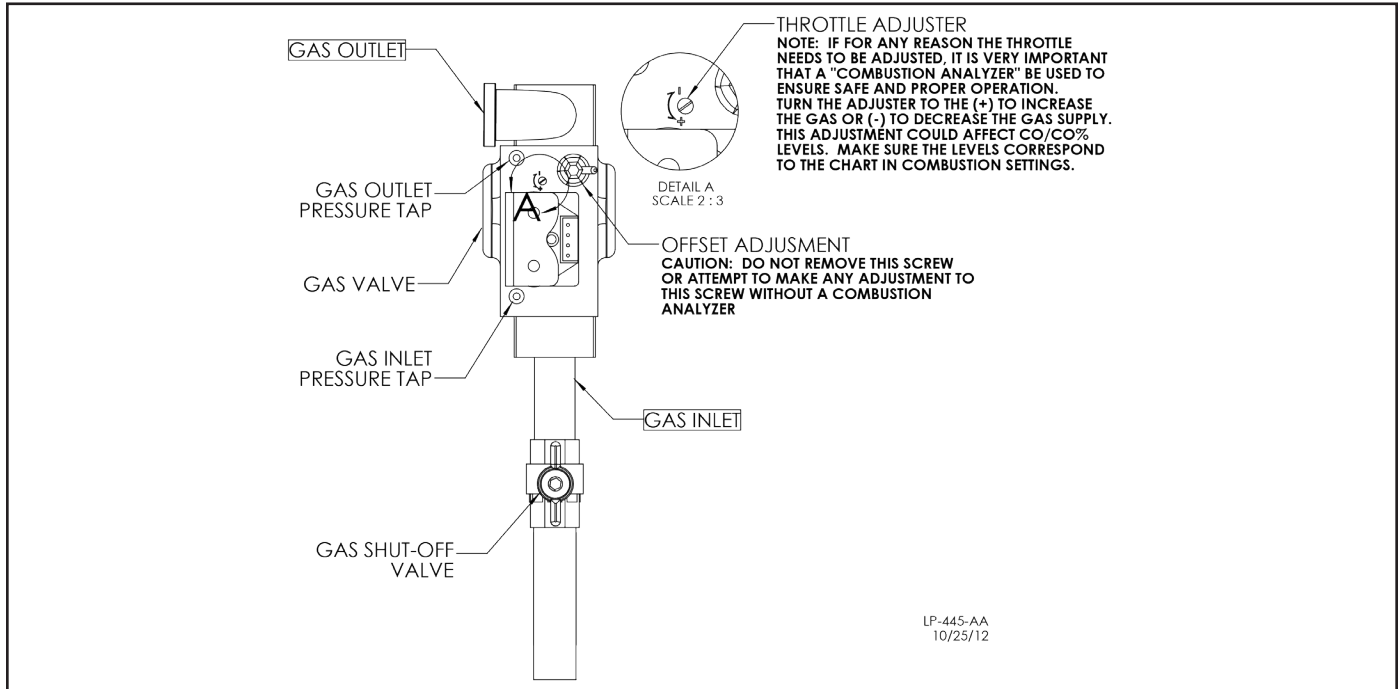

Figure 32 - 500 Model Gas Valve

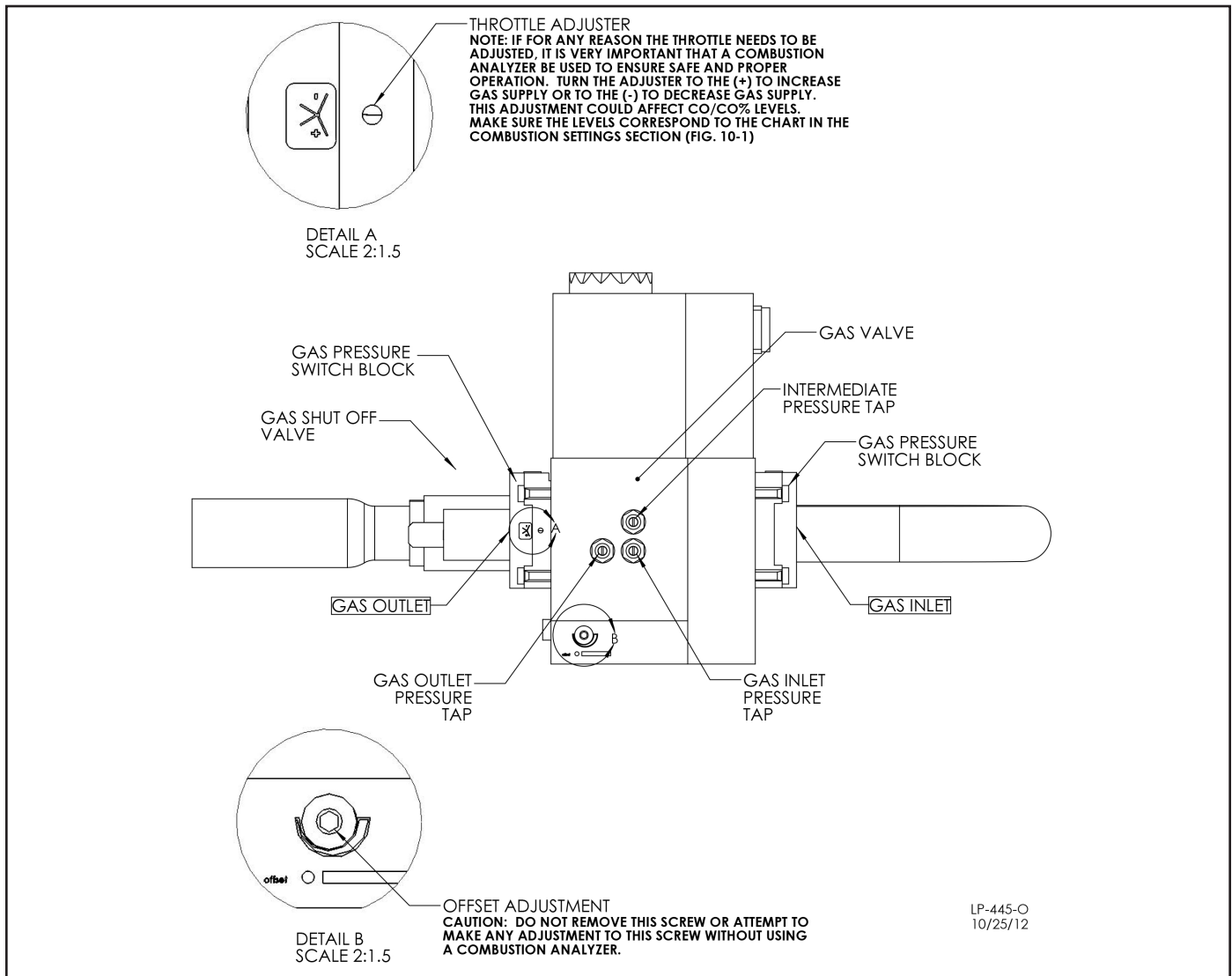

Figure 33 - 700/850 Models Gas Valve

Part 9 - Start-Up Preparation

A. Check / Control Water Chemistry

CAUTION

Chemical imbalance of the water supply may affect efficiency and cause severe damage to the appliance and associated equipment. Water quality must be professionally analyzed to determine whether it is necessary to treat the water. Various solutions are available to adjust water quality. Adverse water quality will affect the reliability of the system. In addition, operating temperatures above 135°F will accelerate the build-up of lime scale and possibly shorten appliance service life. Failure of an appliance due to lime scale build-up, low pH, or other chemical imbalance IS NOT covered by the warranty.

The water must be potable, free of corrosive chemicals, sand, dirt, and other contaminants. It is up to the installer to ensure the water does not contain corrosive chemicals or elements that can damage the heat exchanger. Potable water is defined as drinkable water supplied from utility or well water in compliance with EPA secondary maximum contaminant levels (40 CFR Part 143.3) as shown in the table below. If the water contains contaminants higher than outlined by the EPA, water treatment is recommended and additional, more frequent maintenance may be required.

If you suspect that your water is contaminated in any way, discontinue use of the appliance and contact an authorized technician or licensed professional.

Contaminant	Maximum Allowable Level	Contaminant	Maximum Allowable Level
Total Hardness (Commercial Use - 140°F and above water temperature)	120 mg/l (7 grains/gallon)	pH	6.5-8.5
		Sulfate	205 mg/l
		Total Dissolved Solids (TDS)	500 mg/l
Aluminum	0.05 to 0.2 mg/l	Zinc	5 mg/l
Chloride	100 mg/l		
Copper	1 mg/l	Dissolved Carbon Dioxide (CO ₂)	15 mg/l or PPM
Iron	0.3 mg/l		
Manganese	0.05 mg/l		

CAUTION

Do not use petroleum-based cleaning or sealing compounds in the appliance system. Damage to elastomer seals and gaskets in the system could occur, resulting in substantial property damage.

B. Check for Gas Leaks

WARNING

Before starting the boiler, and during initial operation, smell near the floor and around the boiler for gas odorant or any unusual odor. Remove boiler front door and smell interior of boiler enclosure. Do not proceed with startup if there is any indication of a gas leak. Repair any leaks at once.

PROPANE BOILERS ONLY – The propane supplier mixes an odorant with the propane to make its presence detectable. In some instances the odorant can fade, and the gas may no longer have an odor. Before startup (and periodically thereafter), have the propane supplier verify the correct odorant level in the gas.

C. Condensate Removal

1. The boiler is a high efficiency condensing boiler. Therefore, the unit has a condensate drain. Condensate fluid is nothing more than water vapor, derived from combustion products, similar to that produced by an automobile when it is initially started.

Condensation is slightly acidic (typically with a pH of 3 to 5) and must be piped with the correct materials. Never pipe the condensate using steel, copper, brass or other materials that will be subject to corrosion. Plastic PVC or CPVC pipe are the only approved materials.

A condensate neutralizer, if required by local authorities, can be made up of lime crystals, marble or phosphate chips that will neutralize the condensate. This may be done by the installer or you may purchase a condensate neutralizer from HTP (7350P-611).

2. The boiler is equipped with a 3/4 female socket weld fitting connection that must be piped to a local drain. It is very important that the condensate line is sloped downward away from the boiler to a suitable inside drain. If the condensate outlet on the appliance is lower than the drain, you must use a condensate removal pump, available from HTP (554200). This pump is equipped with two leads that can be connected to an alarm or another type of warning device to alert the user of a condensate overflow, which, if not corrected, could cause property damage.

3. If a long horizontal run is used, it may be necessary to create a vent in the horizontal run to prevent a vacuum lock in the condensate line.

4. Do not expose the condensate to freezing temperatures.

5. It is very important you support the condensation line to assure proper drainage.

D. Final Checks Before Starting Boiler

1. Read Startup Procedures within this manual for proper steps to start boiler. (See Startup Report to record steps for future reference.)

2. Verify the boiler and system are full of water and all system components are correctly set for operation.

WARNING

Ensure the boiler is full of water before firing the burner. Failure to do so will damage the boiler. Such damage IS NOT covered by warranty, and could result in property damage, severe personal injury, or death.

3. Fill condensate trap with water.

4. Verify electrical connections are correct and securely attached.

5. Inspect exhaust vent and intake piping for signs of deterioration from corrosion, physical damage or sagging. Verify exhaust vent and intake piping are intact and correctly installed per Venting Section and local codes.

E. Setting Up a Single Boiler

When power is applied to the boiler, the control first completes a power-up systems check. During this time the combustion fan may run. The display will initially show the current boiler outlet temperature. If a fault is detected during the power-up test, the control will display the appropriate fault code. Otherwise, the display will continue to show the boiler outlet temperature and stand-by, waiting for a demand for hot water. If the temperature of the tank sensor falls below the tank set point minus the tank differential temperature, a demand for hot water is generated by the control.

When a demand for hot water is received, the control begins the following demand sequence. The boiler first turns on the pump (if it is not wired to run continuously). Once the pump is running, the control will display LOW WATER FLOW and wait for the water flow in the system to increase to an acceptable level determined by the flow switch on the outside of the boiler. (NOTE: This step may happen very rapidly. If flow is adequate, LOW WATER FLOW may never display.)

Once flow through the boiler is adequate, the control will measure the supply temperature. If it is below the set point temperature minus the ignition differential set point, the control will ignite the burner. After

the burner is lit, the control modulates the firing rate to control the supply water temperature at the set point temperature plus the supply offset temperature (installer #4) above the tank set point temperature. When the tank temperature is equal to the tank set point temperature, the control will extinguish the burner and run the combustion fan to purge gasses from the combustion chamber. In addition, the pump will run for a pump post purge interval. The control will then be in standby, waiting to process the next demand for heat.

During this process, the control will extinguish the burner if it senses a dangerous or unsafe condition. If the control determines that a dangerous or unsafe condition has occurred, the control may lock out the boiler and prevent it from igniting until a maintenance person diagnoses the problem, repairs it, and resets the control. In the event that the control goes into lockout, it will show a diagnostic code on the display, illuminate the LED fault indicator, and close the alarm relay contacts to aid in recognition of the condition, diagnosis, and repair.

F. Setting Up a Cascaded System

If the boiler is part of a cascaded system the operation is somewhat different. The control of each boiler in a cascaded system completes its own power up system check as described above. One of the boilers in the cascade system is designated as the master boiler. After the master boiler completes its power up sequence, it checks the communication bus to see if any other boilers are present. If other boilers are present, the master control determines these follower boiler addresses. The master boiler control will recheck the bus every few seconds as long as it is powered up to update the status of the connected boilers. The control in the master boiler processes all heat demands and dictates which of the follower boilers should light and what firing rate the followers should try to achieve.

When the master boiler receives a demand for heat, it determines which boiler is first in the firing sequence and sends that boiler a command to begin a demand sequence. That boiler will then begin a demand sequence as described above. Once the boiler ignites, the master boiler control will increase the firing rate command to that boiler until the system sensor temperature is at the tank set point temperature plus the supply offset temperature (installer #4), or that boiler is at high firing rate. If the command from the master boiler control gets to the high firing rate of the follower boiler, but the system sensor is below the required temperature, the master boiler control will then tell the next boiler in the firing sequence to begin its demand sequence. The master boiler control will then begin to ramp up the firing rate command of that boiler. This process will continue while there is a demand until all boilers in the cascade system are at high fire or the desired temperature of the system sensor is reached. If the system sensor temperature reaches tank set point and installer #4 before all boilers are at high fire, the master control will modulate the cascade command signal to maintain the system sensor at tank set point and installer #4 until the demand is complete. When the tank temperature is equal to the set point temperature, the demand is complete, and the master boiler control will extinguish all boilers that may be lit. If the demand decreases, the firing rate command and amount of boilers lit will decrease exactly opposite as described above.

Whenever the master boiler control needs to fire a follower boiler, it sends a firing rate command to that boiler. The follower boiler will respond to the command until its supply sensor temperature gets to be 5°F above the tank set point temperature plus the supply offset temperature (installer #4), at which point the individual boiler will modulate on its own so as not to overheat. As a result, it is not uncommon to see the cascade output at maximum but individual boilers firing at less than their maximum firing rate.

G. Lockout Condition

If any boilers, including the master boiler in the cascade system, are in a lockout condition, the master control will recognize the lockout condition and skip over the boiler in the firing sequence. Each boiler in the cascade system is responsible for its own safety functions. So,

if any individual boiler control senses an unsafe condition, it will extinguish the burner and, if necessary, go to a lockout condition. In this way, every boiler in the system has its individual safety controls intact and operational, even if the firing of the boiler is under control of the master boiler.

In the event that the system sensor fails, all boilers in the system will ignite simultaneously when there is a demand, and each boiler will individually regulate firing rates to maintain the master set point temperature (tank set point + installer #4) at the individual supply sensors built into the boiler. If this should happen, the master boiler will display an E03 fault code, indicating that the supply sensor has failed.

H. Cascade System Programming

1. If the boiler is used alone, skip this section.

2. Programming the Master Boiler:

- a. Make sure there is no demand for heat being supplied to the boiler.
- b. Apply power to the boiler.
- c. Enter the system setting program navigation following instructions in Part 10 of this manual.
- d. Verify that cascade address function 15 is set to 0. This makes the master boiler address 0. NOTE: The Master Boiler MUST be addressed as 0. This establishes the unit as the master in a cascaded system.
- e. Change Cascade Mode function 23 from VISION3 to ALL 926 if cascaded system IS NOT common vented. If cascade system IS common vented, set Function 23 to the total number of boilers in the system (4 BOILERS for a four boiler system, 6 BOILERS for a six boiler system, etc.)
- f. Exit the installer menu.

NOTE: The temperature set point of the master must match the follower boiler set point in order for the system to operate properly.

3. Programming Follower Boilers:

NOTE: READ THE NOTES BELOW BEFORE PROGRAMMING FOLLOWER BOILERS

- The boiler addressed as 1 will share its alarm output with the master boiler.
 - It is recommended but not necessary to address boilers in the order that they are wired.
 - No two boilers can have the same address.
 - It is not required to use all consecutive address numbers.
 - Maximum amount of boilers in a cascaded system is eight (8).
- a. Make sure there is no demand for heat being supplied to the master boiler
 - b. Apply power to the follower boiler you are working on.
 - c. Enter system settings following instructions in Part 10 of this manual
 - d. Set cascade address parameter 15 to 1 for the first follower, 2 for the second follower, etc. depending which boiler you are programming based on the above notes. This establishes the boiler as a follower in a cascaded system and enables data to be transferred as needed for the system to function at full capability. **NOTE:** ONLY select number 8 if using a Vision 3 panel for cascade operations instead of a master boiler.
 - e. Change "CASCADE MODE" Function 23 to "ALL 926" if the cascade system is not to be common vented. If the cascade system IS to be common vented, set Function 23 to COMMON FLUE.
 - f. Exit the installer menu.

NOTE: The temperature set point of the follower must match the master boiler set point in order for the system to operate properly.

Part 10 - Start-Up Procedure



FOR YOUR OWN SAFETY READ BEFORE OPERATING

1. This boiler does not have a pilot. It is equipped with an ignition device which automatically lights the burner. Do not try to light the burner by hand.
2. BEFORE OPERATING: Smell all around the boiler area for gas. Be sure to smell next to the floor because some gas is heavier than air and will settle on the floor.

3. WHAT TO DO IF YOU SMELL GAS

- Do not try to light any boiler.
 - Do not touch any electric switch, do not use any phone in your building.
 - Immediately call your gas supplier from a neighbor's phone. Follow the gas suppliers' instructions.
 - If you cannot reach your gas supplier, call the fire department.
 - Turn off the gas shutoff valve (located outside the boiler) so that the handle is crosswise to the gas pipe. If the handle will not turn by hand, don't try to force or repair it, call a qualified service technician. Force or attempted repair may result in a fire or explosion.
4. Do not use this boiler if any part has been under water. Immediately call a qualified service technician to inspect the boiler and to replace any part of the control system and any gas control that has been damaged.
 5. The boiler shall be installed so the gas ignition system components are protected from water (dripping, spraying, rain, etc.) during boiler operation and service (circulator replacement, condensate trap, control replacement, etc.)

Failure to follow these instructions could result in property damage, serious personal injury, or death.

If you discover any evidence of a gas leak, shut down the boiler at once. Find the leak source with a bubble test and repair immediately. Do not start the boiler again until the leak is repaired. Failure to comply could result in substantial property damage, severe personal injury, or death.

A. Control Overview

The control is one of the primary safety devices of the boiler. It monitors the safety sensors of the boiler to assure safe and efficient operation.

The control has many features associated with system design. This section addresses programming features, including Boiler Settings / System Settings / Maintenance Settings and System Diagnostics, to help in customizing your control. It is important to fully understand control capabilities before customization, as its factory defaults may already fit your system design and not require any adjustment at all.

B. Navigation of the Display

The display includes a two line backlit LCD readout to provide informative messages about the operation of the boiler. Many operating parameters can be viewed and adjusted by using the six buttons on the display. The function of each button is described below.

RESET – The RESET button has two functions.

- Resets any lockout error code
- Returns the user to the default display screen.

ENTER – The ENTER key is used to access parameter programming mode. To access this mode, hold down the ENTER key for more than 4 seconds. The readout will change to:

ENTER MENU CODE
000

One of the zeroes will be blinking. Use the **^ v** arrow keys to change

the blinking digit to the correct value. Use the **< >** arrow keys to select the next digit to change and again use the **^ v** keys to change the value. Repeat until the correct code is entered. Press the **ENTER** key to accept the code entered. If the code is correct, the readout will change to the appropriate screen. If the programming code is not accepted, the readout will continue to display as shown above.

ENTER is also used to enable a function for editing. After the user navigates to the desired function, the user holds down **ENTER** for one second. When **ENTER** is released, the function value will begin to blink. The function can now be changed using the **^ v** keys. After the new value is displayed, the user then presses **ENTER** for 1 second to lock the new value of the function. The value will then stop blinking.

LEFT AND RIGHT ARROW KEYS – **< >** are used to navigate between the default display, status display, analog and cascade displays if they are enabled. The **< >** keys are also used in programming modes to change between programmable functions. It is recommended you use the Menu Maps in the back of this manual and the detailed menu instructions printed in this section to help in menu navigation.

UP AND DOWN ARROW KEYS – **^ v** are used to navigate between the various functions displayed in the menu. After the function is enabled for editing by pushing the **ENTER** key, the **^ v** keys are used to adjust the function upward or downward to the desired value.

C. Operating Instructions

Before operating the unit, it is important to remove the cover and verify that the gas line and water lines are connected to boiler and fully purged. If you smell gas, STOP; Follow the safety instructions listed in the first part of this section. If you do not smell gas, follow the next steps.

1. Turn down the thermostats before applying power to the boiler. If 0–10 volt or other inputs are used, make sure that they are set so there is no call for heat while programming.
2. Turn on the power to the boiler or boilers if a cascade system used.
3. Next, check the boiler settings. Adjustment and factory defaults are outlined within this section. If a cascade system is used, it is important that all the boilers have the same boiler settings.
4. Next, check the system settings. Adjustments and factory defaults are outlined within this section. If a cascade system is used, it is important that the Master Boiler is programmed with the correct system settings.
5. Create a demand on the boiler or boilers if a cascade system is used. The user can monitor system functions when the boilers are operational.
6. If the boilers fail to start, refer to the troubleshooting section in the back of this manual.

D. Programming Boiler Settings

Boiler Setting Program Access

Note: Programming the boiler control is not possible when the boiler is firing. Make sure any input which can create a demand on the boiler, such as the tank thermostat, is turned off, so the boiler will remain idle to allow programming.

Screen	Description
ENTER MENU CODE 000	To access the boiler setting program, press and hold ENTER for 4 seconds until the display shows the screen at left.
ENTER MENU CODE 600	Use the arrow keys to log in the Boiler Menu Access Code - 600 . Press ENTER to confirm the code and access the Boiler Setting Program navigation menu.

Table 20 - Boiler Setting Access

Boiler Setting Program Navigation

Once the code is confirmed, the user can start to set the **Boiler Settings**. Use the arrow keys on the display to navigate through the **Boiler Settings**. A blinking setting indicates the setting can be changed. To change a setting, press **ENTER**. Boiler settings can be increased by pressing **^** and decreased by pressing **v** on the display. When done,

press **ENTER**. The setting will stop blinking and the user can move on to next setting. Press **RESET** to exit programming and store settings. Listed below are the boiler settings that can be programmed into the control.

Screen	Description
IGNITION DIFF SET 7 °F	Allows the user to adjust the ignition differential set point from 1°F to 36°F (Factory Default 7°F). Degrees below set point must be equal to or below tank differentials.
TANK SETPOINT 120 °F	Adjusts the tank set point from 59°F to 180°F (Factory Default 120°F).
TANK DIFF SETPOINT 7 °F	Adjusts the tank differential set point from 1°F to 18°F (Factory Default 7°F). Degrees below set point where demand starts.
TEMP DISPLAY C OR F °F	Adjusts the temperature measurement in F = Fahrenheit to C = Celsius (Default is Fahrenheit).

Table 21 - Boiler Setting Program Navigation

Clock Settings

(NOTE: The clock will reset if the boiler is powered off for more than a week.)

Screen	Description
CLOCK MODE (12/24) 08/28/2009 Fr 9:42A	Changes the clock from 12 hour mode (8:45 PM) to 24 hour mode (20:45). To change to 24 hour mode, press ENTER . The letter (A or P) after the time will blink. Press the up or down arrow key once and the letter will disappear. Press ENTER to save the new setting.
CLOCK HOUR 08/28/2009 Fr 10:01A	Allows the user to adjust the hour setting.
CLOCK MINUTE 08/28/2009 Fr 10:01A	Adjusts the minute setting.
CLOCK DAY OF WEEK 08/28/2009 Fr 10:01A	Adjusts the day of the week.
CLOCK DATE MODE 08/28/2009 Fr 10:01A	Allows the user to switch to European date format (2009/08/28) from US format (08/28/2009).
CLOCK YEAR 08/28/2009 Fr 10:01A	Adjusts the year setting.
CLOCK MONTH 08/28/2009 Fr 10:01A	Adjusts the month setting.
CLOCK DATE 08/28/2009 Fr 10:01A	The clock is set.

Table 22 - Clock Setting Screens

NOTE: The internal clock does not adjust for daylight savings time and requires manual adjustment.

E. Programming the System Setting

System Setting Program Access

Note: Programming the boiler control is not possible when the boiler is firing. Make sure any input which can create a demand on the boiler, such as the tank thermostat, is turned off, so the boiler will remain idle to allow programming.

Screen	Description
ENTER MENU CODE 000	To access the boiler setting program, press and hold ENTER for 4 seconds until the display shows the screen at left.
ENTER MENU CODE 925	Use the arrow keys to log in the Boiler Menu Access Code - 925 . Press ENTER to confirm the code and access the Boiler Setting Program navigation menu.

Table 23 - System Setting Access

F. System Setting Program Navigation

Once the **System Menu Access Code** is confirmed, the user can begin to set the system setting menu. Use the < > keys on the display to navigate through the System Settings. To change a setting, press **ENTER**. System settings can be **increased** by pressing **^** and **decreased** by pressing **v** on the display. When done, press **ENTER**. The setting will stop blinking and you can move on to next setting. Press **RESET** to exit programming and store settings. Listed below are the boiler settings that can be programmed into the control.

Screen	Description
Function 1	Factory Program Mode
MODE VWH MODE 1	This indicates that the control is configured correctly for a volume water heater. Do not change this setting.
Function 3	DHW Tank Max Temp
DHW TANK MAX TEMP 180 °F 3	This is the maximum temperature that can be selected in boiler settings for the DHW tank. Factory Default is 180°F. (Range: 95°F to 180°F)
Function 4	Burner Off Differential
BURNER OFF DIFF 20 °F 4	This is the amount of degrees above tank set point that the burner will maintain its outlet water temperature while there is a demand for heat. Factory Default is 20°F. (Range: 1°F to 45°F)
Function 6	VWH Post Pump Time
VWH POST PUMP TIME 0 MINUTES 6	The boiler pump has the ability to post purge energy from the boiler to the tank after the set point has been achieved. Please note that running the pump for a time greater than 5 minutes may cause tank energy to be released back to the heat exchanger. Factory Default of 0 Minutes. (Range: 0 – 10 minutes)
Function 7	Warm Weather Shutoff
WARM WEATHER OFF 68 °F 7	Not applicable on this product.
Function 8	Min Outdoor Temp
MIN OUTDOOR TEMP 5 °F 8	Not applicable on this product.
Function 9	Max Supply Temp
MAX SUPPLY TEMP 190 °F 9	Not applicable on this product.

Function 10	Max Outdoor Temp
MAX OUTDOOR TEMP 68 °F 10	Not applicable on this product.
Function 11	Min Supply Temp
MIN SUPPLY TEMP 95 °F 11	Not applicable on this product.
Function 12	Min Boiler Temp
MIN BOILER TEMP 68 °F 12	Not applicable on this product.
Function 13	CH Post Pump Time
CH POST PUMP TIME 0 MINUTES 13	Not applicable on this product.
Function 14	DHW Priority
DHW PRIORITY 30 MINUTES 14	Not applicable on this product.
Function 15	Cascade Address
CASCADE ADDRESS 0 15	Bus addressing boilers (maximum boilers allowed 8 in a cascade system). Master Boiler address is 0 and Following Boilers are addressed 1 thru 7. Default: 0 (Range: 0 – 8). NOTE: ONLY USE ADDRESS 8 if using a Vision 3 panel.
Function 16	Optional Inputs
OPTIONAL INPUT RETURN SEN 16	Allows the user to select optional inputs to control or monitor the system. Default: RETURN (Range: Off / Booster Board / 0-10 Volt / DHW Sensor / Return Sen).
Screen	Description
Function 17	0-10 Volt Function
0-10 VOLT FUNCTION TEMPERATURE 17	Control boiler modulation through temperature control. Factory Default = Temperature (Temperature only on VWH).
Function 18	Step Modulation Mode
STEP MODULATE MODE ON 18	Not applicable on this product.
Function 19	Boiler DHW Temp
BOILER SUPPLY DHW 180 °F 19	Not applicable on this product.
Function 20	Water Safety Input
WATER SAFETY INPUT WATER PRESSURE 20	The user can select various water safety inputs used in the boiler system. Default: Flow Switch (Range: None / Low Water Cut Off / Flow Switch / Water Pressure).
Function 21	Error Outdoor Sensor
ERROR OUTD SENSOR OFF 21	Not applicable on this product.
Function 22	Adjust Boiler Output %
ADJ HEATER OUTPUT 100% 22	Adjusts the boiler output down from 100% to 50%. Factory Default: 100%. (Range: 100% – 50%)

Function 23	Cascade Mode
CASCADE MODE VISION 3 23	Allows the user to select cascade mode. Select VISION 3 if boiler is operating alone or using an older Vision 3 control panel for cascade operation. Select ALL 926 to establish a cascaded system WITHOUT common vent. In cascaded systems WITH a common vent, select the number of cascaded boilers in the system on the cascade master (2 BOILERS in a two boiler system, 6 BOILERS in a six boiler system, etc.) On cascade followers in a common vent system, select COMMON FLUE to establish a cascaded system WITH common vent. Factory Default: VISION 3 (Range: VISION 3 / ALL 926 / 2 – 8 BOILERS [on cascade master ONLY] / COMMON FLUE [on cascade followers ONLY]).
Function 24	Cascade Rotation
CASCADE ROTATION 48 HOURS 24	Sets the amount of hours before the first boiler in the cascade firing rotation will be changed. NOTE: If this is set to 0, the firing order of the boilers will not rotate. Default: 48 hours (Range: 0 – 240 hours).
Function 25	Cascade DHW Mode
NOT USED NOT USED 25	Not applicable on this product.
Function 26	System Freeze Protection
SYS FREEZE PROT PROTECT OFF 26	NOTE: This parameter is only present if the boiler is a cascade master. Allows the user to set the freeze protection when a system pump is used. Factory Default: OFF. Selection of temperature activates freeze protection. (Range: OFF, -40°F – 104°F).
Function 27	Error System Sensor
ERROR SYSTEM SENS ON 27	Sets the control to display an error message if the system sensor is open or shorted. NOTE: This error does not stop the boiler (or boilers) from running. Factory Default: ON (Range: ON / OFF).
Function 28	Freeze Protection
FREEZE PROTECTION ON 28	Allows the user to set freeze protection on the boiler. Factory Default: ON (Range: ON / OFF).
Function 29	DHW Modulation Mode
DHW MODULATE MODE NORMAL MOD 29	Not applicable on this product.
Function 30	Extra Boiler Mode
EXTRA BOILER MODE OFF 30	Allows for a non HTP boiler to be controlled when the cascade output has risen above the percent of the cascade firing rate set in this parameter. Factory Default: Off (Range: 50% - 100%).

Function 31	System Sensor Mode
SYSTEM SENSOR MODE OFF 31	Suppresses the 'NO FOLLOWER' display message if the boiler is used as a cascade master boiler with no follower boilers connected. Factory Default: OFF (Range: ON / OFF).
Function 32	Service Schedule
SERVICE SCHEDULE OFF 32	Selects a service date or time based on the boiler run hours to program the boiler maintenance schedule. Factory Default: OFF (Range: Date or Run Hours). NOTE: Without setting this function, Functions 33/34/35/36 will not display.
Function 37	Modbus Mode
MODBUS MODE OFF 37	Enables Modbus Mode on the appliance. Factory Default: OFF (Range: OFF, ON, AUTO). NOTE: Turning Modbus Mode "ON" will open a number of additional parameters to customize Modbus installation. See Modbus Instructions (Ip-372) for details. NOTE: Turning this Mode "ON" without a connected and powered Modbus communication adapter (p/n 7350P-629) will result in improper appliance operation. Service calls associated with this ARE NOT covered by warranty.

Table 24 - System Setting Program Navigation

NOTE: For the following functions, you must have your maintenance function turned on.

To change these functions, press **ENTER**. The left most digit will begin to blink. Use the **^** or **v** arrows to change the digit. Use the **<** **>** arrow keys to switch between digits. When you've made your selection, press **ENTER** again.

Screen	Description
Function 33	Year
SERVICE SCHEDULE YEAR 00/00/2000 33	Allows the user to set the year of the next service reminder.
	Hours
SERVICE SCHEDULE 10000's 000000 33	Allows the user to set the left two digits of the amount of run hours before next service reminder.
Function 34	Month
SERVICE SCHEDULE MONTH 00/00/2000 34	If the date function was selected, this function programs the month. If you selected the run hour function, you will need to program 10,000 hours, if required.
	Hours
SERVICE SCHEDULE 10000's 000000 34	Allows the user to set the middle two digits of the amount of run hours before next service reminder.
Function 35	Day
SERVICE SCHEDULE DAY 00/00/2000 35	Sets the day of next service reminder.

	Hours
SERVICE SCHEDULE 10000's 000000 35	Sets the two right digits of the amount of run hours for the next service reminder.
Function 36	Telephone
TELEPHONE # 000 000 0000 36	Allows the user to input a telephone number that will display when maintenance is required.

Table 25 - Maintenance Reminder Function Screens

G. Resetting the Maintenance Schedule

When the system control flashes MAINTENANCE REQUIRED, it is advisable that you call for service. After the service is performed, reset the schedule for the next required service by using the following steps.

Press **ENTER** on the display for 3 seconds. The Menu code will appear as 000. This does not change. Press **ENTER** again. SERVICE SCHEDULE RESET will be displayed. Using the **>** key scroll to the selection of year or hours. Press **ENTER** to reset the selected Service Schedule. To change a setting, press **ENTER**. Press the **^** and **v** keys to make adjustments. Press **ENTER** when reset is complete.

Part 11 - Start-Up Procedures for the Installer

A. Boiler Control Status Menu

The boiler control also has the ability to review system status. To access the status screens, press **>**. Once the first value is displayed, press **^** and **v** to scroll through additional information. At any point press **RESET** to exit the status screens.

Screen	Description
SUPPLY SEN 180°F RETURN SEN 150°F	This is the first screen that appears after pressing > , and shows the actual temperatures measured by the supply and return sensors. NOTE: If the boiler is configured to use a 0 – 10 volt input, the return sensor is disabled and the second line of the display will be blank.
Press v once.	
NA SUPPLY SEN NA 122°F	The actual temperature measured by the supply sensor is displayed on the bottom.
Press v once.	
0-10 SIGNAL ON *	Shows if 0-10 volt is enabled.
Press v once.	This screen appears only when the boiler is set as a Master Boiler.
CAS SET SYSTEM 190°F 112°F	This screen displays the cascade set point (maximum 190°F) on the top line. The system sensor reading is on the second line. The control will cascade the boilers up to this set point depending on demand.
Press v once.	

TANK SET RET/TANK	120°F OFF	Displays the current tank temperature set point on the top line. The actual temperature measured by the tank or return sensor (HTP 7250P-325) is displayed on the bottom line. If a mechanical aquastat is used in place of the recommended sensor, the second line will display 'OFF' in place of the temperature if the aquastat measures close to its set temperature, or 'ON' if the aquastat temperature is too low.
Press v once.		
NA FLUE	11°F 95°F	The second line displays the current boiler flue temperature.
Press v once.		
FLAME FAN SPEED	0.0uA 3497 RPM	This screen displays boiler flame current on the top line. The second line displays boiler fan speed.
Press v once.		
0-10 V *	0.0V	The top line displays the voltage on the optional input. This voltage is only relevant if an external 0-10 volt signal is being used to control the boiler.
Press v once.		
BUS COMM NO CONN		This display shows the status of the communication bus between multiple boilers. If in a single boiler configuration, the display will show 'NO CONN'. In a multiple boiler configuration, if this is the Master Boiler and other boilers are connected to the communication bus and powered, this screen will show the address of each boiler connected to the bus.
Press v once.		
POWER ON CH ON	0H 0H	The top line indicates the amount of hours the boiler has been powered over its life. The second line is not applicable.
Press v once.		
VWH ON GOOD IGNIT	0H 1X	The top line indicates the hours the burner has been on for hot water demand over the boiler's life. The second line indicates how many times the burner has successfully ignited over the boiler's life.
Press v once.		
SYS CH ON SYS VWH ON	0H 0H	The top line is not applicable. The second line registers system pump hours on the cascade master ONLY.

Table 26 - Boiler Control Status Menu Screens

The next ten screens display the last ten boiler lockout faults. Press v to scroll through the faults from most recent to oldest.

Screen	Description
FAULT HISTORY 07/27/2009 5:19A	1 Mo This screen displays the most recent boiler control lockout fault. The top line will alternate between the words 'FAULT HISTORY' and the fault code encountered. The bottom line displays the date and time the fault occurred.
Press v once.	
FAULT HISTORY 08/28/2009	2 Fr 5:19A This screen displays the second oldest boiler control lockout fault. The top line will alternate between the words 'FAULT HISTORY' and the actual fault encountered. The bottom line will display the date and time that the fault occurred.
Press v once.	
FAULT HISTORY 08/28/2009	3 Fr 5:19A This screen displays the third oldest boiler control lockout fault. The top line will alternate between the words 'FAULT HISTORY' and the actual fault encountered. The bottom line will display the date and time that the fault occurred.
Press v once.	
FAULT HISTORY 08/28/2009	4 Fr 5:19A This screen displays the fourth oldest boiler control lockout fault. The top line will alternate between the words 'FAULT HISTORY' and the actual fault encountered. The bottom line will display the date and time that the fault occurred.
Press v once.	
FAULT HISTORY 08/28/2009	5 Fr 5:19A This screen displays the fifth oldest boiler control lockout fault. The top line will alternate between the words 'FAULT HISTORY' and the actual fault encountered. The bottom line will display the date and time that the fault occurred.
Press v once.	
FAULT HISTORY 08/28/2009	6 Fr 5:19A This screen displays the sixth oldest boiler control lockout fault. The top line will alternate between the words 'FAULT HISTORY' and the actual fault encountered. The bottom line will display the date and time that the fault occurred.
Press v once.	
FAULT HISTORY 08/28/2009	7 Fr 5:19A This screen displays the seventh oldest boiler control lockout fault. The top line will alternate between the words 'FAULT HISTORY' and the actual fault encountered. The bottom line will display the date and time that the fault occurred.
Press v once.	

FAULT HISTORY 08/28/2009	8 Fr 5:19A	This screen displays the eighth oldest boiler control lockout fault. The top line will alternate between the words 'FAULT HISTORY' and the actual fault encountered. The bottom line will display the date and time that the fault occurred.
Press v once.		
FAULT HISTORY 08/28/2009	9 Fr 5:19A	This screen displays the ninth oldest boiler control lockout fault. The top line will alternate between the words 'FAULT HISTORY' and the actual fault encountered. The bottom line will display the date and time that the fault occurred.
Press v once.		
FAULT HISTORY 08/28/2009	10 Fr 5:19A	This screen displays the tenth oldest boiler control lockout fault. The top line will alternate between the words 'FAULT HISTORY' and the actual fault encountered. The bottom line will display the date and time that the fault occurred.

Table 27 - Boiler Fault Screens

B. Cascade Menu

This menu is accessed by pressing < at the default menu or > at the status menu.

Screen	Description
CASCADE MASTER READY SYS PUMP OFF	This screen displays when the boiler is configured as a Cascade Master and the system is ready to accept a demand for heat. The second line indicates the cascade system pump output status. This screen alternates with the default screen every 5 seconds or can be accessed by pressing the < key from the default screen.
CASCADE NO FOLLOWER SYS PUMP OFF	This screen displays when the boiler is configured as a Master Boiler and there are no connected follower boilers, or the follower boilers are not powered. The second line indicates cascade system pump output status. This screen alternates with the default screen every 5 seconds or can be accessed by pressing the < key from the default screen.

CASCADE NO SENSOR SYS PUMP OFF	This screen displays when the boiler is configured as a Master Boiler and there is no system temperature sensor connected or the system sensor is defective. The cascade system will still function in this situation with reduced efficiency. All boilers will run simultaneously rather than in a staged fashion. The second line indicates cascade system pump output status. This screen will alternate with the default screen every 5 seconds or can be accessed by pressing the < key from the default screen.
CASCADE VWH 0123 567 SYS PUMP ON 12:47P	This screen displays information about cascade status. The VWH in the center of the top line shows that cascade demand is coming from the tank sensor or thermostat. You may also see 0-10 if the demand is from a 0-10 volt input. The following numbers show which boiler addresses are currently communicating to the master. If a boiler address is not used or communicating, the number will not display. In the example to the left, boiler address #4 is not communicating. When a boiler in the system is firing, its address number will alternate with a " : " to signify it is firing. The bottom line shows the status of the system pump output contacts.
Press v once.	
CASCADE PWR 100% PRESENT 01234567	This screen displays overall cascade power output. The range of this value is the number of boilers communicating with the Master x 100. For example, if 8 boilers are connected and firing, the maximum cascade power is 800%. The second line shows which boiler addresses are communicating with the Master.
Press v once.	
CASCADE SYST 118°F CASCADE SET 190°F	This screen displays current system temperature sensor reading on the top line and the cascade system temperature setting on the bottom.
Press v once.	
BOILER 0 100% BOILER 1 56%	This screen displays the current cascade power demand output on a per connected boiler basis for boilers addressed as 0 and 1. In the example, boiler 0 is being commanded to fire at 100% and boiler 1 at 56%. If this were a 2 boiler system, the 'CASCADE PWR' screen above would read 156%.
Press v once.	

BOILER 2 BOILER 3	0% 0%	This screen displays the current cascade power demand output on a per connected boiler basis for boilers addressed as 2 and 3.
Press v once.		
BOILER 4 BOILER 5	0% 0%	This screen displays the current cascade power demand output on a per connected boiler basis for boilers addressed as 4 and 5.
Press v once.		
BOILER 6 BOILER 7	0% 0%	This screen displays the current cascade power demand output on a per connected boiler basis for boilers addressed as 6 and 7.

Table 30 - Cascade Menu

C. Boiler Test Mode

This function is intended to simplify gas adjustment. The following tables include recommended combustion settings by fuel type and boiler fan speeds. Automatic modulation does not take place while the controller is in Test Mode. However, the boilers will modulate down if the program set point is reached while running in Test Mode. It is recommended to enter Test Mode with the largest load possible to create such a heat demand that Test Mode will not be interrupted. To enter Test Mode press ^ and ENTER simultaneously. **NOTE:** The boiler will automatically exit Test Mode after 20 minutes of operation.

To leave Test Mode press ^ and v simultaneously.

SERVICE RUN	3400 RPM
PUMP ON	4:49P

Combustion Settings on All Models						
Fan Speed	Natural Gas (NG)			Propane (LP)		
	Low	Ignition	High	Low	Ignition	High
Carbon Monoxide (CO) PPM	5-50	35-100	≤150	5-50	35-100	≤150
Carbon Dioxide (CO ₂) %	8-10	8 1/2-10 1/2		9-10 1/2	9 1/2-11	

Table 28 - Combustion Settings - All Models

Fan Speeds			
Model	Ignition	Min	Max
500	3000	1950	7200
700		2200	5700
850			6800

Table 29 - Fan Speeds

Part 12 - Troubleshooting

A. Boiler Error and Fault Codes

If any of the sensors detect an abnormal condition, or an internal component fails during the operation of the boiler, the display may show an error message and error code. This message and code may be the result of a temporary condition, in which case the display will revert to its normal readout when the condition is corrected, or it may be a condition that the controller has evaluated as not safe to restart the boiler. In this case, the boiler control will be locked out, the red FAULT light will be lit, and the message "LOCKOUT" will be displayed on the readout in the lower line.

The boiler will not start until a qualified technician has repaired the boiler and pressed the RESET button for more than 1 second. If

there is an error message displayed on the readout, and the message "LOCKOUT" is not displayed and the FAULT light is not lit, then the message is the result of a temporary condition and will disappear when the problem corrects itself.

IMPORTANT NOTE: If you see error messages on your display readout, call a technician immediately, since the message may indicate a more serious problem will occur soon.

B. Boiler Error

The controller will display an error code and message when an error condition occurs. These error codes, descriptions, and recommended corrective actions are described in Section D.

C. Boiler Fault

1. The controller will illuminate the red "FAULT" indication light and display a fault code and message when a fault condition occurs. The alarm output will also activate. Most fault conditions cause the CH pump to run in an attempt to cool the boiler.

2. Note the displayed fault code and refer to Section D for an explanation of the message along with several suggestions for corrective actions.

3. Press **RESET** to clear the fault and resume operation. Be sure to observe the operation of the unit for a period of time to assure correct operation and no reoccurrence of fault message.

WARNING

When servicing or replacing components that are in direct contact with boiler water, be certain that:

- There is no pressure in the boiler. (Pull the release on the relief valve. Do not depend on the pressure gauge reading.)
- The boiler water is not hot.
- The electrical power is disconnected.
- The gas is shut off.

Failure to make these checks could result in substantial property damage, serious personal injury, or death.

DO NOT USE THIS APPLIANCE IF ANY PART HAS BEEN SUBMERGED IN WATER.

Immediately call a qualified service technician. The appliance **MUST BE** replaced if it has been submerged. Attempting to operate an appliance that has been submerged could create numerous harmful conditions, such as a potential gas leakage causing a fire and/or explosion, or the release of mold, bacteria, or other harmful particulates into the air. Operating a previously submerged appliance could result in property damage, severe personal injury, or death.

NOTE: Appliance damage due to flood or submersion is considered an Act of God, and IS NOT covered under product warranty.

If overheating occurs or the gas supply fails to shut off, do not turn off electrical power to the circulating pump. This may aggravate the problem and increase the likelihood of boiler damage. Instead, shut off the gas supply to the boiler at the gas service valve. Failure to do so may result in property damage, personal injury, or death.

CAUTION

Label all wires prior to disconnecting them when servicing the boiler. Wiring errors can cause improper and dangerous operation. Failure to follow these instructions may result in property damage or personal injury.

NOTE: If system return temperatures are maintained below the dew point, condensation will form on the inside of the boiler cabinet and cause some internal sheet metal components to rust.

D. User Interface Display

Cascade Control Fault Codes

Screen	Description	Possible Remedy
SYS SUPPLY SENSOR PUMP OFF E03	E03 indicates a problem with the system sensor circuit. The circuit could be open or shorted. Possible reasons for this error are: There is no system sensor connected to the Master Boiler. The system sensor is faulty. There is a short circuit in the system sensor wiring; possibly from a staple placed through the wire, or damage to the wire causing both conductors to touch. The system sensor wiring is open due to defect or damage.	Disconnect the system sensor from the wiring and measure its resistance. Compare the measured resistance to the table in this manual to see if it corresponds to the temperature of the sensor. If the resistance does not agree with the sensor, replace the sensor. If the sensor is OK, disconnect the sensor wiring from both the boiler and the sensor and check continuity using an ohmmeter. Repair or replace as necessary. If this error is present, the boilers in the cascaded group will run and ignite simultaneously when there is a heat demand. Each boiler will modulate to maintain set point temperature on its own supply sensor. This code automatically resets when repair is complete. This code will not display if system setting function ERROR SYSTEM SENS is set to OFF.
TEMPER BLOCKING PUMP ON TT	TT indicates there is a demand for heat on the boiler, the pump is powered on, and the supply sensor temperature is too high for the boiler to ignite. This occurs because the water temperature measured by the supply sensor is higher than the tank temperature – ignition diff setting.	This message will stay present until the water temperature measured by the supply sensor is less than the tank temperature – ignition diff setting.
HIGH FLUE PRESS FLU PUMP ON	FLU indicates excessive flue pressure. This code resets automatically after the high pressure condition is resolved. The second line indicates pump status.	1. Assure the flue is not blocked. 2. Check the switch wiring by applying a jumper in place of the switch. If the code clears with the jumper in place, REPLACE the flue switch and connect the wires to the new switch BEFORE running boiler.
WARNING: Do not use jumper to remedy an FLU error. Faulty switch MUST be replaced. Failure to follow this instruction could result in serious personal injury or death.		
24 VOLT LOW LOU PUMP ON	LOU indicates the 24 volt power supply on the control is damaged or overloaded. This code resets automatically if it is the result of an overload and the overload condition is removed. The second line indicates the status of the pump. Note that while 24 volt power is low, the pump output will be on.	1. Check line voltage. It must be between 100 and 128 volts. 2. If available, connect a PC and use HTP service software to check the 24v supply display in the lower left corner of the screen. The number displayed here must be greater than 128 and should be no greater than 250. Use this as a troubleshooting guide as you follow the steps below. 3. Remove the 10 pin Molex connector from the customer connection board. If the message clears the problem is with external sensor wiring. Examine the external sensor wiring for shorts to the ground, repairing as necessary. If the message is still present and the boiler is so equipped, disconnect the UL 353 low water cut-off to see if the message clears. Replace the faulty part. Check the low voltage wire harness in boiler for shorts to ground. 4. If a message only occurs when the burner tries to light, check the gas valve for excessive current draw. 5. If a message is present when the low voltage harness is disconnected from the 926 control board, replace the 926 control board.
WATER HIGH TEMP F00 PUMP ON	F00 indicates the water in the boiler has overheated. The boiler will not restart until it cools sufficiently and a technician determines and repairs the cause of overheating and pushes RESET on the display. This is a serious safety issue as indicated by the illuminated red light and the word LOCKOUT flashing on the display. During this lockout fault, the pump will be on in an effort to cool the boiler down.	1. Check circulator pump operation. 2. If the circulator pump is running, ensure there is water in the system and that the water is moving through the system as intended. Ensure that all correct ball valves and or zone valves are open or closed as intended. 3. Observe the temperature/pressure gauge. If the water is not too hot and this message is displayed, check the wiring to the water ECO sensor and repair if necessary. If the wiring is ok and this code is still present and the water is not excessively hot, replace the ECO sensor.

Screen	Description	Possible Remedy
FLUE TEMP/WAT LV F01 PUMP ON	<p>This code indicates that one of the safety interlock switches present in the unit has tripped. There are several interlock switches that could possibly trip and cause this error. The following four switches are installed and are standard equipment in all boilers.</p> <ol style="list-style-type: none"> 1. Flue ECO – Trips if the flue temperature is excessive. This switch has to be manually reset. 2. Boiler module thermal fuse – Trips if there is excessive heat on the rear of the heat exchanger. 3. Boiler module front temperature switch - Trips if there is excessive heat on the front of the heat exchanger. 4. Blocked vent pressure switch (BVPS) – This switch trips if there is excessive pressure in the flue and automatically resets. <p>The following switches are optional equipment that may be installed on the VWH. These devices have indicator lights on them showing if they are tripped.</p> <ol style="list-style-type: none"> 1. High gas pressure switch – This switch trips if there is excessive gas pressure on the outlet side of the gas valve and must be manually reset. 2. Low gas pressure switch – This switch trips if there is low gas pressure on the inlet side of the gas valve and must be manually reset. 3. UL 353 Low Water Cutoff – This device trips if the water level in the boiler is low and must be manually reset. 	<ol style="list-style-type: none"> 1. Check to see if the boiler with the F01 code displayed has any of the optional switches installed. 2. If so, check to see if the indicator light on any of the devices is showing that they are tripped. 3. If an indicator light is illuminated, investigate the source of the error for that particular switch. 4. If there are no optional switches or none of the indicator lights is illuminated on the optional switches then use an ohmmeter to test each of the standard switches one at a time. Turn the power off to the boiler and disconnect the switch to be tested from the boiler to determine which one has tripped. When you find the tripped switch investigate the cause of the fault based on the purpose of the switch. NOTE: The common reasons for the temperature switches to trip are a) low water flow through the boiler, or b) poor heat transfer from the water to the load. 5. If no switches are tripped, push RESET on the boiler. If the boiler tries to ignite or ignites and only runs for a short time and the F01 code returns, investigate the flue for blockage.
SUPPLY SENSOR F02 PUMP ON	<p>F02 indicates the supply temperature sensor of the boiler has failed. The boiler will not restart until a technician replaces the sensor and pushes RESET on the display. This is a serious safety issue as indicated by the illuminated red light and the word LOCKOUT flashing on the display. During this lockout fault, the pump will be on.</p>	<ol style="list-style-type: none"> 1. Check the electrical connection to the thermistor on the outlet manifold. Verify 5 VDC by checking the Molex connector. If there is no 5 VDC, check the harness. If harness is OK, replace the control. Verify thermistor values by referencing chart in this manual. 2. Replace thermistor if necessary. <p>NOTE: The boiler will reset automatically once the fault is corrected.</p>
RETURN SENSOR F03 PUMP ON	<p>F03 indicates the return temperature sensor of the boiler has failed. The boiler will not restart until a technician replaces the sensor and pushes RESET on the display. This is a serious safety issue as indicated by the illuminated red light and the word LOCKOUT flashing on the display. During this lockout fault, the pump will be on.</p>	<ol style="list-style-type: none"> 1. Check circulator pump operation. 2. Ensure adequate flow through the boiler by accessing the status menu and determining there is less than a 50°F rise from the return thermistor to the supply thermistor. 3. Troubleshoot thermistor by following the steps in F02.
FLUE SENSOR F04 PUMP ON	<p>F04 indicates that the flue temperature sensor of the boiler has failed. The boiler will not restart until a technician replaces the sensor and pushes RESET on the display. This is a serious safety issue as indicated by the illuminated red light and the word LOCKOUT flashing on the display. During this lockout fault, the pump will be on.</p>	<p>Inspect the flue sensor for physical damage or corrosion and replace it if necessary. Check the electrical connection to the flue sensor and repair as necessary. Measure the resistance of the sensor and refer to the sensor resistance table in this manual. The temperature on the chart should be close to the temperature in the flue. If not, replace the flue sensor.</p>

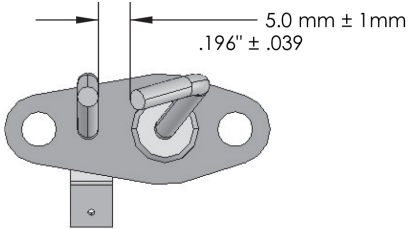
Screen	Description	Possible Remedy
<p>SUPPLY TEMP HIGH F05 PUMP ON</p>	<p>F05 indicates the boiler supply temperature is excessive. When accompanied by the red FAULT light and LOCKOUT flashing on the display, this code indicates the supply sensor temperature has exceeded 230°F and a serious safety issue exists. The boiler will not restart until a technician determines and repairs the cause of excessive temperature and pushes RESET on the display. If the FAULT light is not illuminated and this message is displayed, the supply temperature of the boiler is at or above 210°F. The message will clear automatically when the temperature drops below 194°F. During the time that this fault is displayed, the pump will be on.</p>	<ol style="list-style-type: none"> 1. Check circulator pump operation. 2. Ensure adequate flow through the boiler by accessing the status menu and determining there is less than a 50°F rise from the return thermistor to the supply thermistor. 3. Check the direction of flow off the boiler circulator. (See Piping Details in this manual.) 4. Troubleshoot the thermistor by following steps in F02.
<p>RETURNTEMP HIGH F06 PUMP ON</p>	<p>This display indicates that the boiler return temperature is excessive. When accompanied by the red FAULT light and LOCKOUT flashing on the display, this code indicates that the return sensor temperature has exceeded 230°F and a serious safety issue exists. The boiler will not restart until a technician determines and repairs the cause of excessive temperature and pushes RESET on the display. If the red FAULT light is not illuminated and this message is displayed, then the return temperature of the boiler is at or above 210°F. The message will clear automatically when the temperature drops below 194°F. During the time that this message or lockout fault is displayed, the pump will be on.</p>	<ol style="list-style-type: none"> 1. Check circulator pump operation. 2. Ensure adequate flow through the boiler by accessing the status menu and determining there is less than a 50°F rise from the return thermistor to the supply thermistor. 3. Check the direction of flow on boiler circulator. (See Piping Details in this manual.) 4. Troubleshoot thermistor by following steps in F02.
<p>NO FLAME ON IGN F09 PUMP ON</p>	<p>The boiler tried to ignite four times during one heat call and failed. This is a serious safety issue as indicated by the illuminated red light and the word LOCKOUT flashing on the display. The boiler will not restart until a technician determines and repairs the cause of ignition failure and pushes RESET on the display. During this lockout fault, the pump will remain on.</p>	<ol style="list-style-type: none"> 1. Watch the igniter through the observation window. 2. If there is no spark, check the spark electrode for the proper .196" (5.0 mm ± 1mm) gap. See below. 3. Remove any corrosion from the spark electrode and flame rectifier probe. 4. If there is a spark but no flame, check the gas supply to the boiler. 5. If there is a flame, check the flame sensor. 6. Check any flue blockage or condensate blocks. <div style="text-align: center;">  <p>Spark Electrode Gap Spacing Top View</p> </div> <p>NOTE: If receiving an F09 fault code, check the gap spacing between points on the electrode.</p>

<p>FLAME LOSS PUMP ON</p> <p>F10</p>	<p>The flame was lost 3 times while the boiler was firing during 1 demand call. This is a serious safety issue as indicated by the illuminated red light and the word LOCKOUT flashing on the display. The boiler will not restart until a technician determines and repairs the cause of flame loss and pushes RESET on the display. During this lockout fault, the pump will be on.</p>	<ol style="list-style-type: none"> 1. Monitor gas pressure to the unit while in operation. 2. Assure the flame is stable when lit. 3. Check if the display readout changes from "GAS VALVE ON" to "RUN" within a few seconds of boiler ignites. 4. Check the FLAME signal on the display. It should be above 1.0 when the boiler is firing. 5. If the signal reads less than 1 microampere, clean the flame rectifier and spark probe. 6. If the problem persists and the 'FLAME" signal is still less than 1.0, replace the flame probe and spark igniter probe. 7. The flame signal should be steady after the boiler has been firing for 1 minute and is normally at 5.0 to 9.0. If the flame signal is not steady, disassemble the burner door and check the burner and its sealing gaskets.
<p>FALSE FLAME SIG PUMP ON</p> <p>F11</p>	<p>There is flame when the control is not telling the boiler to run. This is a serious safety issue as indicated by the illuminated red light and the word LOCKOUT flashing on the display. The boiler will not restart until a technician determines and repairs the cause and pushes RESET on the display. During this lockout fault, the pump will be on.</p>	<ol style="list-style-type: none"> 1. Look into window. If there is flame, turn the gas off to the unit at the service valve and replace the gas valve. 2. If the flame signal on the status menu is greater than 1.0 when the burner is not lit, replace the spark ignitor and the flame rectification probe. 3. If the flame signal is not present after turning off the gas supply, check the gas valve electrical connection. 4. Check for condensate backup. Repair condensate system as necessary. If condensate has partially filled the combustion chamber, the refractory wall may be damaged and should be replaced. 5. Turn the gas on at the service valve after corrective action is taken. 6. If the refractory wall falls against the rectifier probe, it may conduct the signal to ground, giving a false reading.
<p>FAN SPEED ERROR PUMP ON</p> <p>F13</p>	<p>The fan is not running at the speed determined by the control. Fan speed has been more than 30% faster or slower than the commanded speed for more than 10 seconds. This is a serious safety issue as indicated by the illuminated red light and the word LOCKOUT flashing on the display .This boiler will not restart until a technician determines and repairs the cause and pushes RESET on the display. During this lockout fault, the pump will be on.</p>	<ol style="list-style-type: none"> 1. Check the combustion fan wiring. 2. Measure DC voltage from the red fan wire to ground while it is connected to the fan. It should be between 24 and 40 volts. If it is lower than 24 volts, check for excessive external loads connected to the boiler sensor terminals 3. Disconnect the 5 pin plug from the fan and check the voltage on the red wire again. If it is now between 24-40 volts, replace the fan. If it is still below 24 volts replace the boiler control board.
<p>FLAP CLOSED</p> <p>F15</p>	<p>Flapper valve physically stuck closed.</p>	<ol style="list-style-type: none"> 1. Check flue system for obstructions. 2. Check proper communication between boilers. 3. Check operation of flapper valve. 4. Check wiring between valve and controller. 5. Replace valve-flapper.
<p>FLAP OPEN</p> <p>F16</p>	<p>Flapper valve physically stuck open.</p>	<ol style="list-style-type: none"> 1. Check flue system for obstructions. 2. Check proper communication between boilers. 3. Check operation of flapper valve. 4. Check wiring between valve and controller. 5. Replace valve-flapper.
<p>CONDENSATE FULL PUMP OFF</p> <p>F20</p>	<p>The condensate trap is full. This is a serious safety issue as indicated by the illuminated red light and the word LOCKOUT flashing on the display. The boiler will not restart until a technician determines and repairs the cause and pushes RESET on the display. During this lockout fault, the pump will be off.</p>	<ol style="list-style-type: none"> 1. Check condensate lines for obstructions. 2. Check float switch in condensate reservoir. 3. Check wiring from condensate reservoir to 926 control and repair as necessary.

Screen	Description	Possible Remedy
PROGRAM ERROR F31 PUMP OFF	There was an error while programming the control and the memory is corrupt. The boiler control will not function in this state and the pump will be off as indicated on the bottom line. This error only occurs if a technician is programming the control and the programming function fails. The only way to recover from this error is to reprogram the control. If this error occurs at any time other than when a technician is servicing the boiler, the control has failed and must be replaced by a qualified technician.	The control must be reprogrammed. If programming does not solve the problem, the control must be replaced.
CONTROL PROGRAMED PP	The control has been programmed by a technician or the factory. After programming, the control is left in a locked out mode.	Press RESET for at least 1 second to use the control.
LOW WATER FLOW FL PUMP ON	FL indicates there is low water flow in the boiler. FL only displays on VWH products. This code automatically resets when water flow is high enough for the boiler to run safely. The second line indicates pump status. The pump should always be on when this code is displayed. When there is a demand, the control will start the pump, wait for the flow switch to indicate flow then try to ignite the boiler. This display occurs after the pump is energized for several seconds and the flow is still too low.	<ol style="list-style-type: none"> 1. Check to see if boiler pump is functioning. Repair as necessary. 2. Be sure water is flowing in the system. Check for valves that should be open, plugged filter screens, etc. 3. Check the flow switch and wiring. Repair as necessary.
The following blocking codes will block operation until the control determines the situation safe for boiler operation.		
FLUE TEMP HIGH E07 PUMP OFF TIME	E07 indicates the flue sensor temperature is excessive and above 210°F. When E07 is displayed the boiler will not respond to a demand for heat. When the flue temperature decreases below 194°F, the display will return to normal and allow the boiler to respond to a heat demand. The bottom line indicates the status of the pump. The pump will remain off when this error is displayed.	Check the flue for obstructions and any sign of damage, especially signs of excessive heat. Repair as necessary. Run the boiler and check the flue temperature with an external thermometer. If the flue temperature on the thermometer does not agree with the flue temperature displayed in the status menu, inspect the wiring to the flue temperature sensor in the boiler and repair as necessary. If the wiring is intact replace the flue sensor. If the flue temperature is excessive on the status menu and the test thermometer reads the same, check and adjust combustion controls on the boiler. If the problem persists, inspect the target wall in the combustion chamber and replace it if cracked or damaged.
COMMON FLUE BLOCK E16	Common flue blocking or flapper valve feedback failure.	<ol style="list-style-type: none"> 1. Ensure boiler is properly programmed. 2. Check flue system for obstructions. 3. Check proper communication between boilers. 4. Check operation of flapper valve. 5. Check wiring between valve and controller. 6. Replace valve-flapper.
LINE VOLTAGE E19 PUMP OFF	E19 indicates the line voltage frequency is out of range. This could happen if the boiler is being powered from a small gasoline powered generator that is overloaded or not functioning correctly.	Inspect power wiring to the boiler and repair as necessary. If connected to line voltage, notify the power company. If connected to an alternate power source such as a generator or inverter, make sure the line voltage frequency supplied by the device is 60 Hz.

Table 31 - Boiler Error and Fault Codes

Part 13 - Maintenance

A. Procedures

Periodic maintenance should be performed once a year by a qualified service technician to assure that all the equipment is operating safely and efficiently. The owner should make necessary arrangements with a qualified heating contractor for periodic maintenance of the boiler. The installer must also inform the owner that a lack of proper care and maintenance of the boiler may result in a hazardous condition.

 WARNING
<p>BEFORE EACH HEATING SEASON a trained and qualified service technician should perform the inspections as per the boiler inspection and maintenance schedule in this manual. Failure to do so could result in death or serious injury.</p> <p>The combustion chamber insulation in this product contains ceramic fiber material. Ceramic fibers can be converted to cristobalite in very high temperature applications. The International Agency for Research on Cancer (IARC) has concluded, "Crystalline silica inhaled in the form of quartz or cristobalite from occupational sources is carcinogenic to humans (Group 1)."</p> <ul style="list-style-type: none"> • Avoid breathing dust and contact with skin and eyes. • Use a NIOSH certified dust respirator (N95). This type of respirator is based on the OSHA requirements for cristobalite at the time this document was written. Other types of respirators may be needed depending on job site conditions. Current NIOSH recommendations can be found on the NIOSH website: http://www.cdc.gov/niosh/homepage.html. NIOSH approved respirators, manufacturers, and phone numbers are also listed on this website. • Wear long-sleeved, loose fitting clothing, gloves, and eye protection. • Apply enough water to the combustion chamber lining to prevent dust. • Wash potentially contaminated clothes separately from other clothing. Rinse clothes washer thoroughly. <p>NIOSH stated First Aid.</p> <ul style="list-style-type: none"> • Eye: Irrigate immediately. • Breathing: Fresh air.

B. Combustion Chamber Coil Cleaning Instructions

*Before beginning this procedure, have on hand the following items:

- a nylon, stainless steel, or brass brush (not steel)
 - gloves and eye protection
1. Shut down the boiler by using the following steps:
 - a. Close the gas valve. Shut down the unit, and wait for it to be cool to the touch.
 - b. Disconnect the condensate piping from the outside connection, (not from the boiler side), so flow from condensate reservoir can be observed.
 - c. Disconnect electrical connections from the gas valve, spark electrode, flame rectification probe, and combustion blower.
 - d. Remove the four (4) screws on the aluminum 3/4" NPT connector on the right side of the gas valve.
 - e. Disconnect the wiring connected to the combustion blower motor.
 - f. Remove the six (6) 10MM nuts from the burner plate assembly.
 - g. Pull the entire burner plate assembly with blower still attached towards you, while removing or pushing aside any wiring to allow removal of the assembly.
 2. Spray the coils liberally with a spray bottle filled with clear tap water. Confine the spray to the area being cleaned. Avoid getting the ceramic target wall wet. If the condensate system is blocked, use a vacuum to clear it.

Outdoor Sensor (7250P-319)		Supply Temperature Sensor (7250P-324) Boiler Sensor (7250P-667) Indirect Sensor (7350P-325)	
Outside Temperature (°F)	Resistance (ohms)	High / Low Temp Sensor Temp. (°F)	Resistance (Ohms)
-22	171800	32	32550
-13	129800	41	25340
-4	98930	50	19870
5	76020	59	15700
14	58880	68	12490
23	45950	77	10000
32	36130	86	8059
41	28600	95	6535
50	22800	104	5330
59	18300	113	4372
68	14770	122	3605
77	12000	131	2989
86	9804	140	2490
95	8054	149	2084
104	6652	158	1753
113	5522	167	1481
		176	1256
		185	1070
		194	915
		202	786
		212	667

Table 32 - Sensor Temperature Resistance

3. Scrub coils of any buildup with a nylon, stainless steel, or brass brush. Do not use a steel brush. Vacuum the debris from the coils.

4. Spray the coils again with clear tap water. Confine the spray to the area being cleaned. Flush the combustion chamber with fresh water until it runs clear from the condensate reservoir. At this point, the boiler should be ready to be reassembled.

- a. Inspect gaskets.
- b. Reinstall the burner assembly
- c. Replace and tighten the six (6) 10MM nuts to the burner plate using staggered tightening sequence. (See detail.)
- d. Reconnect all wiring connections
- e. Inspect the gas valve. Ensure the O-ring is in place.
- f. Replace the four (4) screws on the aluminum connector on the gas valve. Turn the gas back on. (IMPORTANT: CHECK FOR GAS LEAKS!)
- g. Turn boiler power back on and create a heat demand. When boiler is lit observe condensate flow from the boiler. Be sure the boiler is operating properly.
- h. Reconnect the condensate piping to the outside condensate connection.

 WARNING
<p>Do not use solvents to clean any of the burner components. The components could be damaged, resulting in unreliable or unsafe boiler operation, substantial property damage, severe personal injury, or death.</p>

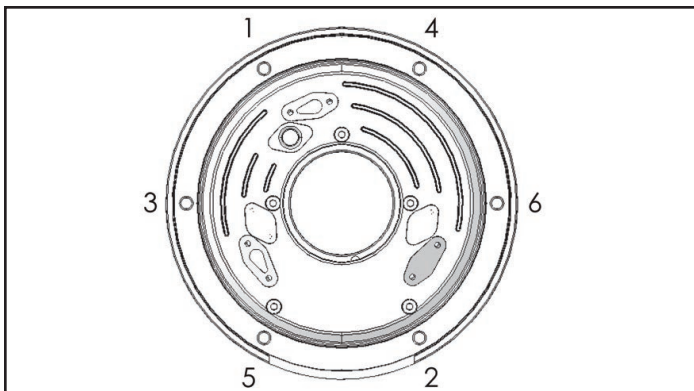

Figure 34 - Heat Exchanger Detail

C. Cleaning Water Side of Heat Exchanger

1. Make sure power is turned off to the boiler. Run water through the hot water system to ensure it is below room temperature.

2. Close isolation valves on the return and supply connections to the boilers as shown in the piping diagrams in this manual. Slowly open the ball valves and release pressure into a bucket. Once pressure is released, connect a hose to the water line to flush the boiler. Scale removing solution may be used, but must be approved for use with stainless steel and FDA approved for use in a potable water system.

3. Thoroughly flush the heat exchanger before commissioning the unit back in service.

! DANGER

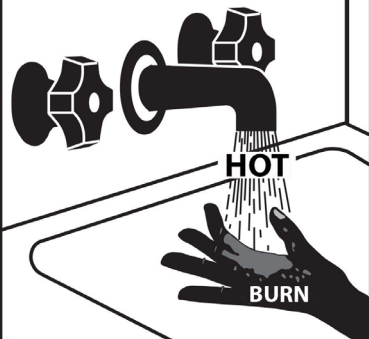

Water temperature over 125°F can cause severe burns instantly or death from scalds. Children, disabled and elderly are at highest risk of being scalded. See instruction manual before setting temperature at water heater. Feel water before bathing or showering. Temperature limiting valves are available, see manual.

Part 14 - Installation Checklist

Light Off Activities		Date Completed:	
1. Fill the Heating System	Check all piping and gas connections. Verify all are tight.		
	Pressurize system.	PSI	
	Add water to prime condensate cup.		
	Verify near boiler piping is properly supported.		
2. Check Gas Pipe	Leak test using locally approved methods (consult jurisdictional code book).		
	Check incoming gas pressure (3.5 to 14" WC).	Static WC	
	Check the "drop" on light off (less than 1" WC).		Dynamic WC
3. Check Combustion	Check and adjust (if necessary) carbon dioxide content.	%CO2 High Fire	%CO2 Low Fire
	Check and adjust (if necessary) carbon monoxide content.	ppm CO High Fire	ppm CO Low Fire
4. Check Electrical Connections	Ensure all electrical connections of line voltage (pumps, etc.) and low voltage circuits (system sensor, outdoor sensor, etc.) are properly wired.		
5. Verify System Operation	Turn up thermostat to verify wiring connections.		
6. Record Ionization Current	Check uA reading at d7 on the status menu (see Start-Up section, this manual).	uA High Fire	uA Low Fire
7. Storage Tank	Verify safety and operation of the storage tank. Record settings.	DHW Setpoint	DHW Differential
8. Mixing Valve	Ensure thermostatic mixing valve is properly supported and installed.		
9. Convert the Boiler (500 Model ONLY)	If necessary, convert the boiler to the proper fuel type.		
	Locate the stickers in the appropriate locations on the boiler.		
	Verify combustion settings after gas conversion - Carbon Dioxide.	%CO2 High Fire	%CO2 Low Fire
	Verify combustion settings after gas conversion - Carbon Monoxide.	ppm CO High Fire	ppm CO Low Fire
	Mail in conversion registration.		
Notes:			

Table 33 - Installation Checklist

Part 15 - Maintenance Report

CAUTION
In unusually dirty or dusty conditions, care must be taken to keep boiler cabinet door in place at all times. Failure to do so VOIDS the warranty.
 WARNING
Allowing the boiler to operate with a dirty combustion chamber will hurt operation. Failure to clean the heat exchanger as needed by the installation location could result in boiler failure, property damage, personal injury, or death. Such product failures ARE NOT covered under warranty.

The boiler requires minimal periodic maintenance under normal conditions. However, in unusually dirty or dusty conditions, periodic vacuuming of the cover to maintain visibility of the display and indicators is recommended.

Periodic maintenance should be performed once a year by a qualified service technician to assure that all the equipment is operating safely and efficiently. The owner should make necessary arrangements with a qualified heating contractor for periodic maintenance of the boiler. Installer must also inform the owner that the lack of proper care and maintenance of the boiler may result in a hazardous condition.

Inspection Activities		Date Last Completed			
Piping		1st Year	2nd Year	3rd Year	4th Year*
Near boiler piping	Check boiler and system piping for any sign of leakage; make sure pipes are properly supported.				
Vent	Check condition of all vent pipes and joints. Ensure the vent piping terminations are free of obstructions and blockages.				
System		1st Year	2nd Year	3rd Year	4th Year*
Visual	Do a full visual inspection of all system components.				
Functional	Test all functions of the system (Heat, Safeties).				
Temperatures	Verify safe settings on boiler or anti-scald valve.				
	Verify programmed temperature settings.				
Electrical					
Connections	Check wire connections. Make sure connections are tight.				
Smoke and CO Detector	Verify devices are installed and working properly. Change batteries if necessary.				
Circuit Breakers	Check to see that the circuit breaker is clearly labeled. Exercise circuit breaker.				
Switch and Plug	Verify ON/OFF switch and convenience plug are both functional.				
Chamber / Burner		1st Year	2nd Year	3rd Year	4th Year*
Combustion Chamber	Check burner tube and combustion chamber coils. Clean according to maintenance section of manual. Vacuum combustion chamber. Replace any gaskets that show signs of damage.				
Spark Electrode	Clean. Set gap at 1/4" Clean probe with plumbers cloth to remove oxides.				
Combination Ignitor and Flame Probe	Check ionization in uA (d7 in Status Menu in Start-Up Procedures). Record high fire and low fire. Clean probe with plumbers cloth to remove oxides.				
Condensate		1st Year	2nd Year	3rd Year	4th Year*
Neutralizer	Check condensate neutralizer. Replace if necessary.				
Condensate Pipe	Disconnect condensate pipe. Clean out dirt. Fill with water to level of outlet and reinstall. (NOTE: Verify the flow of condensate, making sure that the hose is properly connected during final inspection.)				
Gas		1st Year	2nd Year	3rd Year	4th Year*
Pressure	Measure incoming gas pressure (3.5 to 14" WC).				
Pressure Drop	Measure drop in pressure on light off (no more than 1" WC).				
Check Gas Pipe for Leaks	Check gas piping. Test for leaks and signs of aging. Make sure all pipes are properly supported.				
Combustion		1st Year	2nd Year	3rd Year	4th Year*
CO / CO2 Levels	Check CO and CO2 levels in exhaust. See Start-Up Procedures for ranges. Record at high and low fire.				
Safeties		1st Year	2nd Year	3rd Year	4th Year*
ECO (Energy Cut Out)	Check continuity on flue and water ECO. Replace if corroded.				
Flow Switch	Activate heating call and monitor system to ensure flow switch and pump are operating correctly.				
Sensors	Check wiring. Verify through ohms reading.				
Final Inspection		1st Year	2nd Year	3rd Year	4th Year*
Check List	Verify that you have completed entire check list. WARNING: FAILURE TO DO SO COULD RESULT IN SERIOUS INJURY OR DEATH.				
Homeowner	Review what you have done with the homeowner.				

Table 34 - *Continue annual maintenance beyond the 4th year as required.

Part 16 - Replacement Parts

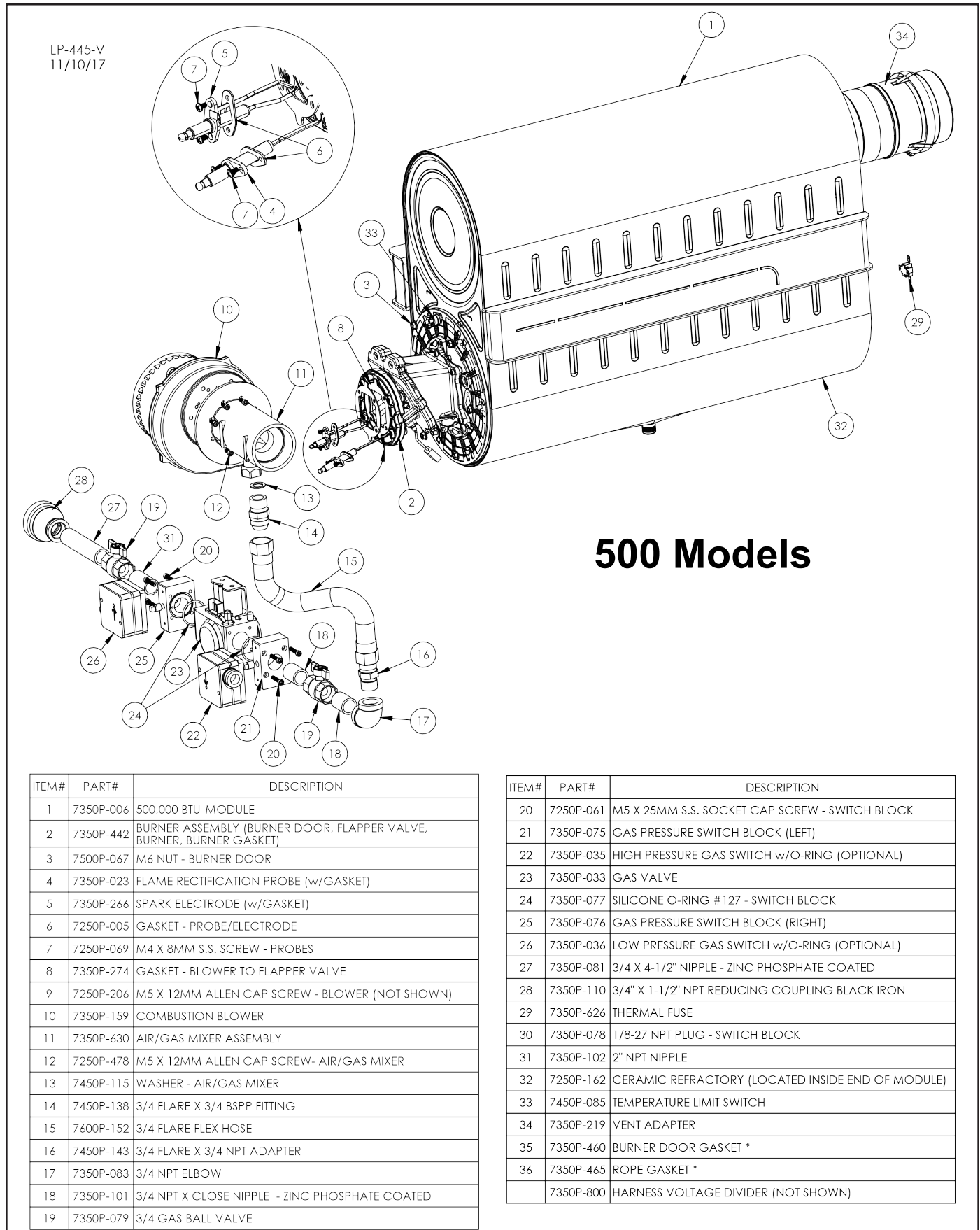
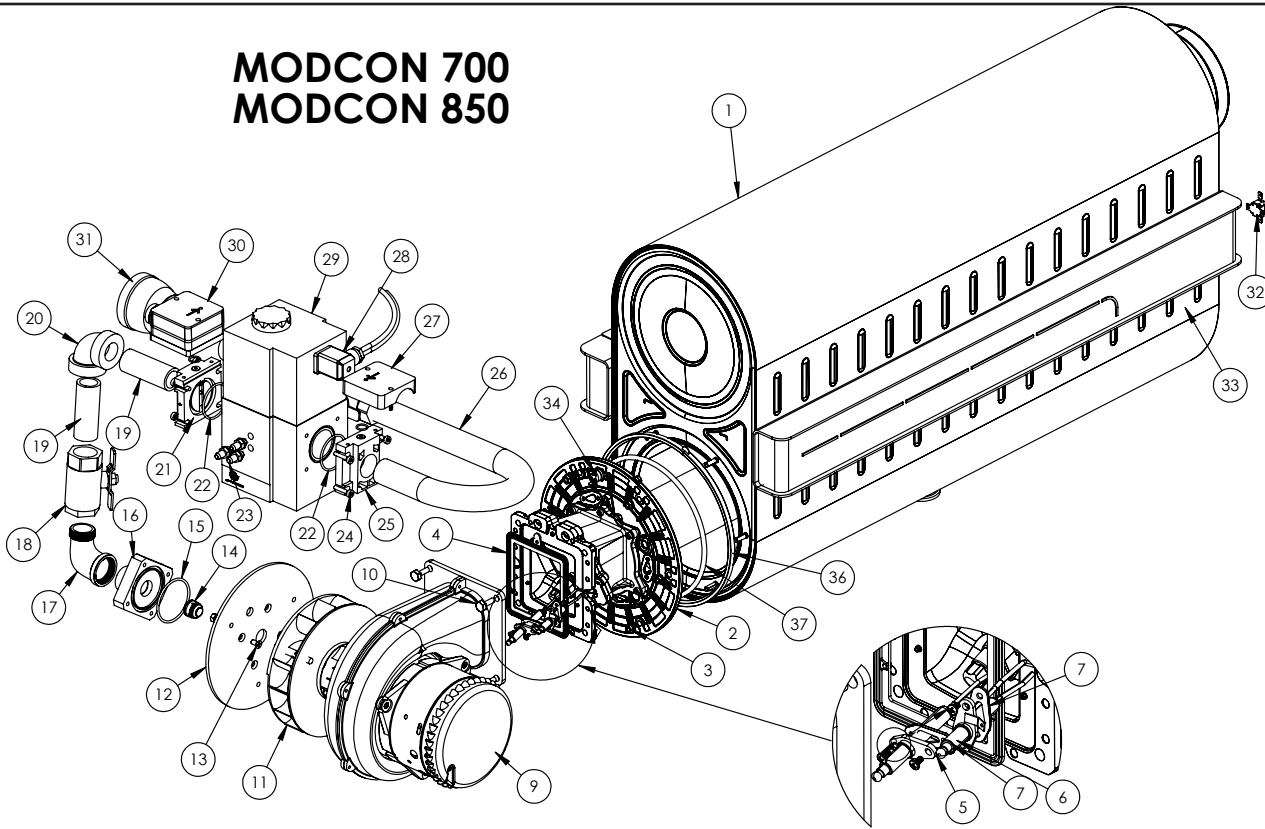

Figure 35 - 500 Model Combustion System Replacement Parts - *Not Shown

MODCON 700 MODCON 850



ITEM#	PART#	DESCRIPTION
1	7350P-007	850,000 BTU MODCON MODULE
2	7350P-443	BURNER ASSEMBLY (BURNER DOOR, FLAPPER VALVE, BURNER, BURNER GASKET)
3	7500P-067	M6 NUT - BURNER DOOR
4	7350P-064	GASKET - BLOWER TO FLAPPER VALVE
5	7350P-023	FLAME RECTIFICATION PROBE (w/GASKET)
6	7350P-266	SPARK ELECTRODE (w/GASKET)
7	7250P-005	GASKET - PROBE/ELECTRODE
8	7250P-069	M4 X 8MM CHEESE HEAD PHILLIPS SCREWS - PROBE/ELECTRODE
9	7350P-238	COMBUSTION BLOWER
10	7350P-093	M8 X 20MM HEX HEAD BOLT - BLOWER
11	7350P-034-1	SWIRL PLATE w/ STUDS, WASHERS
12	N/A	MOUNTING PLATE
13	N/A	M6 X 24MM FLAT HEAD SCREW - ADAPTER FLANGE
14	N/A	O-RING - BLOWER ADAPTER FLANGE
15	7350P-034-4	12MM GAS INJECTOR
16	7350P-034-2	BLOWER ADAPTER FLANGE (includes O-RING, SCREWS)
17	7350P-096	1" M X 1" F STREET ELBOW - ZINC PHOSPHATE COATED
18	7350P-099	1" GAS BALL VALVE

ITEM#	PART#	DESCRIPTION
19	7350P-098	1" NPT X 3" NIPPLE - ZINC PHOSPHATE COATED
20	7350P-095	1" NPT 90 DEGREE ELBOW
21	7350P-034-3	MAXIMUM FLOW RESTRICTOR FLANGE
22	N/A	O-RING - FLANGES
23	7350P-034-6	AIR ADJUSTMENT PORTS
24	N/A	M6 X 25MM SCREWS - FLANGE
25	7350P-034-5	1" NPT FLANGE
26	7350P-082	GAS PIPE ASSY w/SHUT-OFF - 1-1/4 IPS X 1 IPS
27	7350P-036	LOW PRESSURE GAS SWITCH w/O-RING (OPTIONAL)
28	7350P-034-8	HIRSCHMAN CONNECTOR
29	7350P-034	GAS VALVE (includes O-ring, Screws)
30	7350P-035	HIGH PRESSURE GAS SWITCH w/O-RING (OPTIONAL)
31	7350P-109	1-1/4" - 2" REDUCING COUPLING
32	7350P-626	THERMAL FUSE
33	7250P-162	CERAMIC REFRACTORY (LOCATED INSIDE END OF MODULE)
34	7450P-085	TEMPERATURE LIMIT SWITCH
35	7350P-420	VENT ADAPTER
36	7350P-460	BURNER DOOR GASKET
37	7350P-465	ROPE GASKET
	7350P-800	HARNES VOLTAGE DIVIDER

LP-445-S
2/9/22

Figure 36 - 700/850 Models Combustion System Replacement Parts

Model	Control Board Part Numbers	Model	Control Board Part Numbers
MODCON500VWH	7350P-1301	MODCON850VWH	7350P-1303

Table 35 - Control Board Replacement Part Numbers

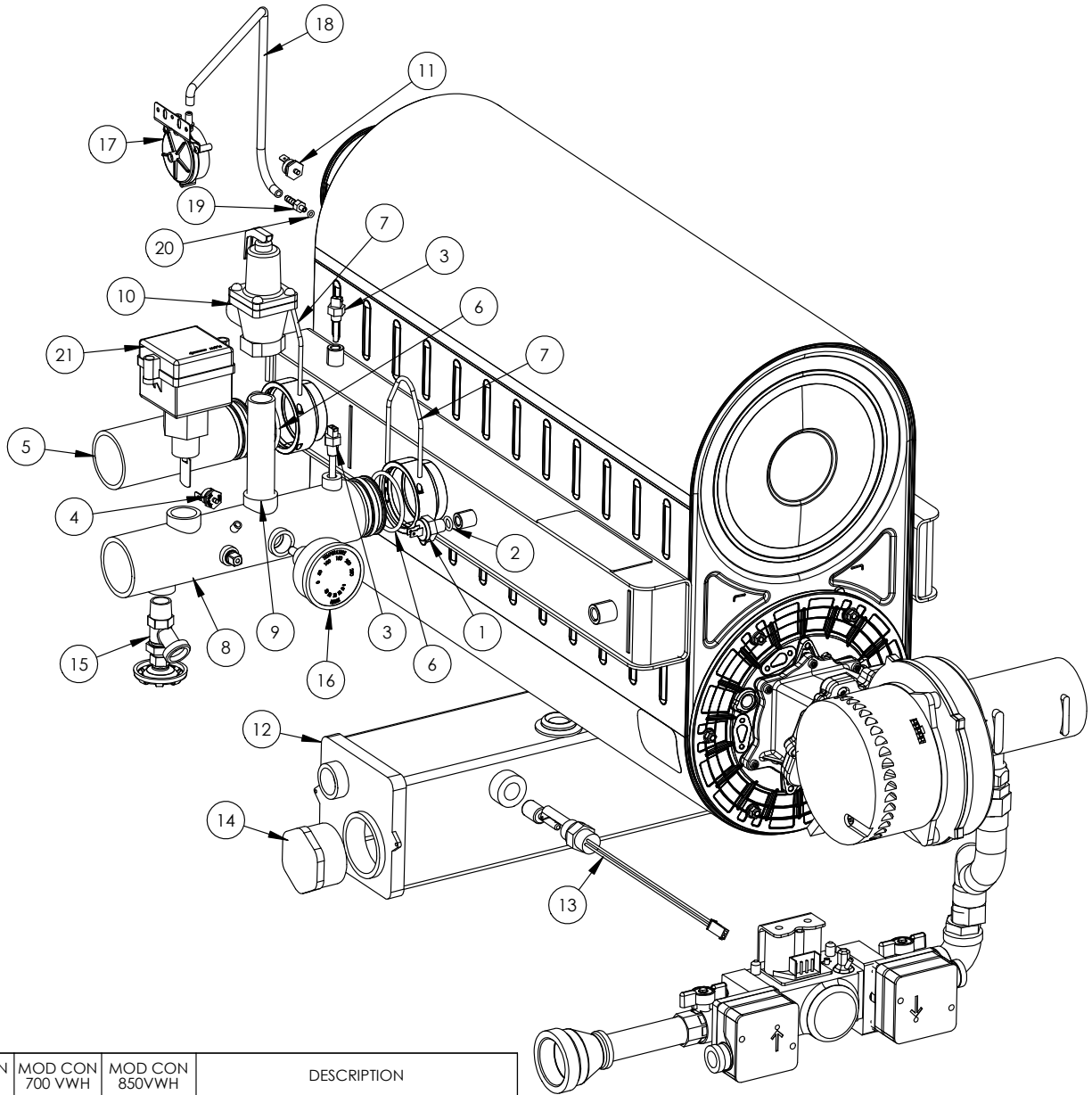

ITEM	MOD CON 500VWH	MOD CON 700 VWH	MOD CON 850VWH	DESCRIPTION
1	7500P-033	7500P-033		ECO HIGH LIMIT SENSOR(W/O-RING)
2	7500P-100	7500P-100		O-RING-ECO HIGH LIMIT SENSOR
3	7450P-280	7450P-280		SENSOR, NTC
4	7500P-002	7500P-002		ECO SWITCH-190 DEGREES
5	7350P-004	7350P-004		2" INLET /NIPPLE (w/O-RING)
6	7350P-072	7350P-072		O-RING- INLET/OUTLET NIPPLE
7	7350P-015	7350P-015		2" INLET NIPPLE CLIP
8	7350P-319	7350P-319		2" OUTLET NIPPLE (w/O-RING)
9	SN1018	SN1018		3/4"NPT X 3" NIPPLE - BRASS
10	7350P-065	7350P-065		150# RELIEF VALVE=3/4" NPT
11	7250P-739	7250P-739		FLUE ECO SWITCH - 160 DEGREES
12	7350P-613	7350P-613		CONDENSATE COLLECTOR ASSEMBLY
13	7350P-167	7350P-167		CONDENSATE OVERFLOW SWITCH
14	7350P-113	7350P-113		2" PVC PLUG
15	7350P-277	7350P-277		DRAIN VALVE
16	7250P-499	7250P-499		TEMP/PRESSURE GAUGE
17	7250P-150	7250P-150		PRESSURE SWITCH
18	7000P-805	7000P-805		PLASTIC TUBING 3/16 ID X 5/16 OD X 12"
19	7250P-154	7250P-154		S.S. BARBED FITTING 1/4 HOSE X 10-32
20	7250P-152	7250P-152		O-RING, SILICONE 2-007 - BARBED FITTING
21	7250P-517			FLOW SWITCH FOR MOD CON VWH

Figure 37 - Water Side Replacement Parts - All Models

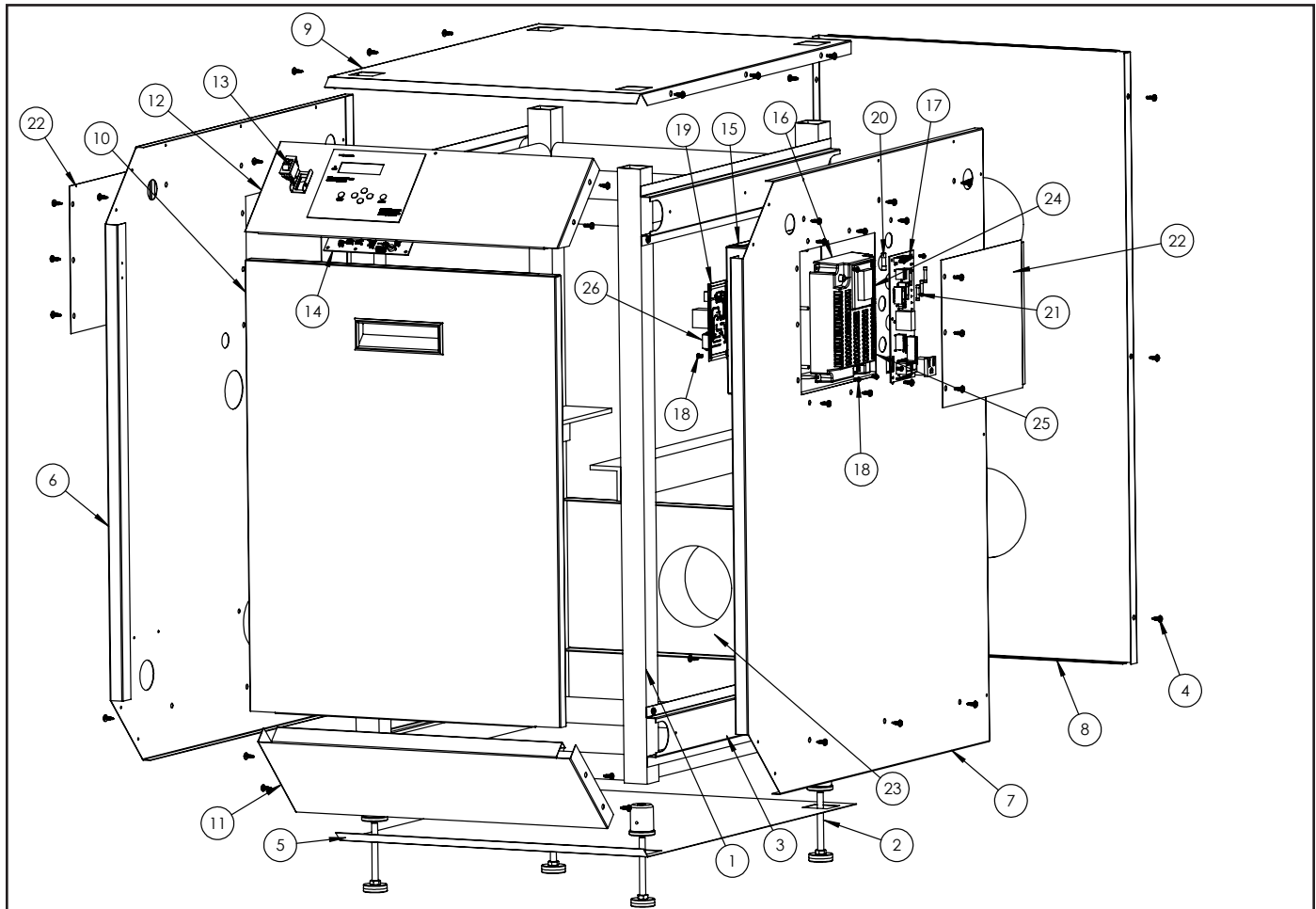

ITEM#	ModCon 500	Modcon 700	ModCon 850	Description
1	7350P-345		7350P-346	MODCON FRAME
2	7250P-673		7250P-673	LEVELING FOOT/MOUNT KIT (SINGLE MODELS ONLY)
3	7350P-316		7350P-069	JACKET MOUNTING BRACKET
4	7350P-063		7350P-063	# 10 X 1/2" SELF TAPPING SCREW
5	7350P-315		7350P-061	JACKET - BOTTOM (w/SCREWS)
6	7350P-313		7350P-057	JACKET - LEFT SIDE (w/SCREWS)
7	7350P-314		7350P-058	JACKET - RIGHT SIDE (w/SCREWS)
8	7350P-049		7350P-126	JACKET - REAR (w/SCREWS)
9	7350P-312		7350P-052	JACKET - TOP (w/SCREWS)
10	7350P-087		7350P-087	JACKET - FRONT
11	7350P-048		7350P-048	JACKET - LOWER FRONT (w/SCREWS)
12	7350P-748		7350P-748	JACKET - UPPER FRONT (INCLUDES PANEL, DISPLAY AND SWITCH)
			7350P-146	JACKET - UPPER FRONT (PANEL ONLY)
13	7500P-087		7500P-087	POWER SWITCH
14	7450P-028		7450P-028	DISPLAY BOARD
15	7350P-042		7350P-042	ELECTRICAL BOX
16	SEE CHART			926 CONTROL BOARD
17	7350P-070		7350P-070	FIELD CONNECTION BOARD
18	7500P-115		7500P-115	SCREW - PAN HEAD 6-32 X 1/4
19	N/A		7250P-580	RELAY BOARD
20	7250P-378		7250P-378	FUSE - CONTROL BOARD - 6.3 AMPS
21	7350P-129		7350P-129	FUSE - CONNECTION BOARD - 3.15 AMPS
22	7350P-062		7350P-062	ELECTRICAL BOX/ACCESS PANEL COVER
23	7350P-103		7350P-104	AIR INLET BRACKET
24	7350P-632		7350P-633	120V WIRING HARNESS (LOCATION)
25	7350P-737		7350P-736	LOW VOLTAGE WIRING HARNESS (LOCATION)
26	N/A		7350P-012	BLOWER WIRING HARNESS (LOCATION)

LP-445-B
03/03/22

Figure 38 - Cabinet Replacement Parts - All Models

VWH Limited Warranty

Five (5) year warranty to assure your complete satisfaction.

HTP warrants each VWH and its parts to be free from defects in materials and workmanship according to the following terms, conditions, and time periods. UNLESS OTHERWISE NOTED THESE WARRANTIES COMMENCE ON THE DATE OF INSTALLATION. This limited warranty is only available to the **original consumer purchaser** (hereinafter "Owner") of the VWH, and is non-transferable.

Commercial Use Warranty Five (5) years – Heat Exchanger, One (1) Year – Components
--

COVERAGE

A. During the first year after the original date of installation, HTP warrants that it will repair or replace, at its option, any defective or malfunctioning component of the VWH with a component of equivalent size and current model. Replacement components will be warranted for ninety (90) days.

B. Should a defect or malfunction result in a leakage of water from the VWH within the above-stated warranty periods due to defective material or workmanship, malfunction, or failure to comply with the above warranty, with such defect or malfunction having been verified by an authorized HTP representative, HTP will replace the defective or malfunctioning VWH with a replacement of the nearest comparable model available at the time of replacement. The replacement VWH will be warranted for the unexpired portion of the applicable warranty period of the original VWH.

C. In the event of a leakage of water of a replacement VWH due to defective material or workmanship, malfunction, or failure to comply with the above warranty, HTP reserves the right to refund to the Owner the published wholesale price available at the date of manufacture of the original VWH.

D. If government regulations, industry certification, or similar standards require the replacement VWH or component(s) to have features not found in the defective VWH or component(s), the Owner will be charged the difference in price represented by those required features. If the Owner pays the price difference for those required features and/or to upgrade the size and/or other features available on a new replacement VWH or component(s), the Owner will also receive a complete new limited warranty for that replacement VWH or component(s).

E. If at the time of a request for service the Owner cannot provide a copy of the original sales receipt or the warranty registration, the warranty period for the VWH shall then be deemed to have commenced thirty (30) days after the date of manufacture of the VWH and NOT the date of installation of the VWH.

F. This warranty extends only to VWHs utilized in water heating applications that have been properly installed by qualified professionals based upon the manufacturer's installation instructions.

G. It is expressly agreed between HTP and the Owner that repair, replacement, or refund are the exclusive remedies of the Owner.

OWNER RESPONSIBILITIES

The Owner or Qualified Installer / Service Technician must:

1. Have a relief valve bearing the listing marks of the American Society of Mechanical Engineers (ASME) installed with the VWH assembly in accordance with federal, state, and local codes.
2. Have a vacuum relief valve certified to ANSI Z21.22 - Relief Valves for Hot Water Supply Systems installed with the VWH assembly in accordance with federal, state, and local codes and in installations prone to vacuum related damages.

3. Maintain the VWH in accordance with the maintenance procedure listed in the manufacturer's provided instructions. Preventive maintenance can help avoid any unnecessary breakdown of the VWH and keep it running at optimum efficiency.
4. Maintain all related system components in good operating condition.
5. Use the VWH in an open system, or in a closed system with a properly sized and installed thermal expansion tank.
6. Use the VWH at water pressures not exceeding the working pressure shown on the rating plate.
7. Keep the VWH free of damaging scale deposits.
8. Make provisions so if the VWH or any component or connection thereto should leak, the resulting flow of water will not cause damage to the area in which it is installed.

WARRANTY EXCLUSIONS

This limited warranty will not cover:

1. Any VWH purchased from an unauthorized dealer or online retailer.
2. Any VWH not installed by a qualified heating installer/service technician, or installations that do not conform to ANSI, CSA, and/or UL standards, as well as any applicable national or local building codes.
3. Service trips to teach you how to install, use, maintain, or to bring the VWH installation into compliance with local building codes and regulations.
4. The workmanship of any installer. The manufacturer disclaims and does not assume any liability of any nature caused by improper installation, repair, or maintenance.
5. Electricity or fuel costs, or increased or unrealized savings for same, for any reason whatsoever.
6. Any water damage arising, directly or indirectly, from any defect in the VWH or component part(s) or from its use.
7. Any incidental, consequential, special, or contingent damages or expenses arising, directly or indirectly, from any defect in the VWH or the use of the VWH.
8. Failure to locate the VWH in an area where leakage of the VWH or water line connections and the relief valve will not result in damage to the area adjacent to the VWH or lower floors of the structure, as well as failure to install the VWH with properly designed containment measures.
9. Any failed components of the heat system not manufactured by HTP as part of the VWH.
10. VWHs repaired or altered without the prior written approval of HTP.
11. Damages, malfunctions, or failures resulting from improper installation, or failure to install the VWH in accordance with applicable building codes/ordinances or good plumbing and electrical trade practices; or failure to operate and maintain the VWH in accordance with the manufacturer's provided instructions.
12. Damages, malfunctions, or failures resulting from failure to operate the VWH at pressures not exceeding the working pressure shown on the rating label.
13. Failure to operate the VWH in an open system, or in a closed system with a properly sized and installed thermal expansion tank.
14. Failure or performance problems caused by improper sizing of the VWH, expansion device, piping, or the gas supply line, the venting connection, combustion air openings, electric service voltage, wiring or fusing.
15. Damages, malfunctions, or failures caused by improper conversion from natural gas to LP gas or LP gas to natural gas.
16. Damages, malfunctions, or failures resulting from vacuum conditions.
17. Damages, malfunctions, or failures caused by operating the VWH with modified, altered, or unapproved parts.
18. Damages, malfunctions, or failures caused by abuse, accident,

fire, flood, freeze, lightning, electrochemical reaction, acts of God and the like.

19. Failures (leaks) caused by operating the VWH in a corrosive or contaminated atmosphere.

20. Damages, malfunctions, or failures caused by operating the VWH with an empty or partially empty tank ("dry firing"), or failures caused by operating the VWH when it is not supplied with potable water, free to circulate at all times.

21. Failure of the heater due to the accumulation of solid materials and lime deposits.

22. Any damage or failure resulting from improper water chemistry. WATER CHEMISTRY REQUIREMENTS - Water pH between 6.5 and 8.5. Hardness less than 7 grains (120 mg/L). Chloride concentration less than 100 ppm (mg/L). TDS less than 500 ppm (mg/L).

23. Any damages, malfunctions, or failures resulting from the use of dielectric unions.

24. Production of noise, taste, odors, discoloration, or rusty water.

25. VWHs replaced for cosmetic reasons.

26. Components of the VWH that are not defective, but must be replaced during the warranty period as a result of reasonable wear and tear.

27. Components of the VWH that are subject to warranties, if any, given by their manufacturers; HTP does not adopt these warranties.

28. Damages, malfunctions, or failures resulting from the use of any attachment(s) not supplied by HTP.

29. VWHs installed outside the fifty states (and the District of Columbia) of the United States of America and Canada.

30. VWHs moved from the original installation location.

31. VWHs that have had their rating labels removed.

PROCEDURES FOR WARRANTY SERVICE REQUESTS

Any claim for warranty assistance must be made immediately upon finding the issue. First, please consult the HTP Warranty Wizard (<http://www.htproducts.com/Warranty-Wizard.html>) to check warranty eligibility. You may also contact HTP Technical Support at 1-800-323-9651 for questions or assistance. Warranty coverage requires review and approval of the issue with HTP Technical Support or through the Warranty Wizard prior to a full unit replacement. Any claim for warranty reimbursement will be rejected if prior approval from HTP is not obtained in advance of a full unit replacement. Final determination will be made as part of the warranty claim process.

When submitting a warranty claim the following items are required:

1. **Proof of purchase or installation of the product** – Typically a copy of the invoice from the installing contractor, the receipt of the purchase of the product, or an original certificate of occupancy for a new home.
2. **Clear pictures (or video) of the following:**
 - a. Serial number tag (sticker)
 - b. The product
 - c. The product issue / failure whenever possible
 - d. A picture of the piping near the product
 - e. For gas fired products, a picture of the venting, including how it exits the building

All claims will be reviewed by HTP within three (3) business days. If additional information is required and requested by the HTP Claims Department you will have thirty (30) days to provide it. When all requested information is provided HTP will respond within three (3) business days. The claim will be automatically closed if requested information is not provided within thirty (30) days. Claims will not be reopened without HTP Warranty Supervisor approval.

During the claims process a product that must be replaced will be given a designation of either a) field scrap, or b) return to HTP. If

the product must be returned to HTP, the returned product must arrive at HTP within thirty (30) days of the date of our request to return the product. After receipt of the returned product HTP may require as many as thirty (30) additional days for product testing. **NOTE: Any components or heaters returned to HTP for warranty analysis will become the property of HTP and will not be returned, even if credit is denied.**

If you have questions about the coverage of this warranty, please contact HTP at the following address or phone number: HTP, 272 Duchaine Blvd., New Bedford, MA, 02745, Attention: Warranty Service Department, 1(800) 323-9651.

SERVICE, LABOR, AND SHIPPING COSTS

Except when specifically prohibited by the applicable state law, the Owner, and not the Manufacturer, shall be liable for and shall pay for all charges for labor or other expenses incurred in the removal, repair, or replacement of the VWH or any component part(s) claimed to be defective or any expense incurred to remedy any defect in the product. Such charges include, but are not necessarily limited to:

1. All freight, shipping, handling, and delivery costs of forwarding a new VWH or replacement part(s) to the owner.
2. All costs necessary or incidental in removing the defective VWH or component part(s) and installing a new VWH or replacement part(s).
3. All administrative fees incurred by the Owner, as well as material required to complete, and/or permits required for, installation of a new VWH or replacement part(s), and
4. All costs necessary or incidental in returning the defective water heater or component part(s) to a location designated by the manufacturer.

LIMITATIONS OF YOUR HTP WARRANTY AND REMEDIES
THE FOREGOING WARRANTIES ARE EXCLUSIVE AND ARE GIVEN AND ACCEPTED TO THE FURTHEST EXTENT UNDER APPLICABLE LAW IN LIEU OF ANY AND ALL OTHER WARRANTIES, EXPRESS OR IMPLIED, INCLUDING WITHOUT LIMITATION THE IMPLIED WARRANTIES OF MERCHANTABILITY AND FITNESS FOR A PARTICULAR PURPOSE AND ANY OBLIGATION, LIABILITY, RIGHT, CLAIM OR REMEDY IN CONTRACT OR TORT, WHETHER OR NOT ARISING FROM HTP'S NEGLIGENCE, ACTUAL OR IMPUTED. THE REMEDIES OF THE OWNER SHALL BE LIMITED TO THOSE PROVIDED HEREIN TO THE EXCLUSION OF ANY OTHER REMEDIES INCLUDING WITHOUT LIMITATION, INCIDENTAL OR CONSEQUENTIAL DAMAGES, SAID INCIDENTAL AND CONSEQUENTIAL DAMAGES INCLUDING, BUT NOT LIMITED TO, PROPERTY DAMAGE, LOST PROFIT OR DAMAGES ALLEGED TO HAVE BEEN CAUSED BY ANY FAILURE OF HTP TO MEET ANY OBLIGATION UNDER THIS AGREEMENT INCLUDING THE OBLIGATION TO REPAIR AND REPLACE SET FORTH ABOVE. NO AGREEMENT VARYING OR EXTENDING THE FOREGOING WARRANTIES, REMEDIES OR THIS LIMITATION WILL BE BINDING UPON HTP. UNLESS IN WRITING AND SIGNED BY A DULY AUTHORIZED OFFICER OF HTP. THE WARRANTIES STATED HEREIN ARE NOT TRANSFERABLE AND SHALL BE FOR THE BENEFIT OF THE OWNER ONLY.

NO OTHER WARRANTIES

This warranty gives you specific legal rights, and you may also have other rights that vary from state to state. Some states do not allow the exclusion or limitation of incidental or consequential damages so this limitation or exclusion may not apply to you. These are the only written warranties applicable to the VWH manufactured and sold by HTP. HTP neither assumes nor authorizes anyone to assume for it any other obligation or liability in connection with said VWHs. HTP reserves the right to change specifications or discontinue models without notice.

Customer Installation Record Form

The following form should be completed by the installer for you to keep as a record of the installation in case of a warranty claim. After reading the important notes at the bottom of the page, please also sign this document.

Customer's Name	
Date of Installation	
Installation Address	
Product Name / Serial Number(s)	
Comments	
Installer's Code / Name	
Installers Phone Number	
Signed by Installer	
Signed by Customer	
Installation Notes	

IMPORTANT

Customer: Please only sign after the installer has fully reviewed the installation, safety, proper operation, and maintenance of the system. If the system has any problems please call the installer. If you are unable to make contact, please call your sales representative.
 Distributor / Dealer: Please insert contact details.